



Website:<http://biz.LGservice.com>  
E-mail:<http://www.LGService.com/techsup.html>

# COLOR MONITOR SERVICE MANUAL

CHASSIS NO. : CL-42

**MODEL: FLATRON L1810B (L1810BL-AL\*\*R)**

( ) **\*\*Same model for Service**

## CAUTION

BEFORE SERVICING THE UNIT,  
READ THE **SAFETY PRECAUTIONS** IN THIS MANUAL.



**\*To apply the Mstar Chip.**

# CONTENTS

SPECIFICATIONS .....	2	ADJUSTMENT .....	12
PRECAUTIONS .....	4	TROUBLESHOOTING GUIDE .....	13
TIMING CHART .....	5	PRINTED CIRCUIT BOARD.....	17
OPERATING INSTRUCTIONS .....	6	EXPLODED VIEW.....	20
WIRING DIAGRAM .....	8	REPLACEMENT PARTS LIST .....	22
BLOCK DIAGRAM .....	9	PIN CONFIGURATION.....	26
DESCRIPTION OF BLOCK DIAGRAM.....	10	SCHEMATIC DIAGRAM.....	28

## SPECIFICATIONS

### 1. LCD CHARACTERISTICS

Type : TFT Color LCD Module  
 Size : 18.1inch(45.974cm diagonal)  
 Pixel Pitch : 0.2805(H) x 0.2805(V)  
 Color Depth : 8-bit, 16,777,216 colors  
 Electrical Interface : LVDS  
 Surface Treatment : Anti-Glare, Hard Coating(3H)  
 Operating Mode : Normally Black  
 Backlight Unit : 6-CCFL (Cold Cathode Fluorescent Lamp)

### 2. OPTICAL CHARACTERISTICS

2-1. Viewing Angle by Contrast Ratio  $\geq 10$

**Left** : -60° min., -80°(Typ)  
**Right** : +60° min., +80°(Typ)  
**Top** : +60° min., +80°(Typ)  
**Bottom** : -60° min., -80°(Typ)

2-2. Luminance : 200(min), 250(Typ)

2-3. Contrast Ratio : 200(min), 350(Typ)

### 3. SIGNAL (Refer to the Timing Chart)

3-1. Sync Signal

• Type : Separate, Composite, SOG (Sync On Green) Digital

3-2. Video Input Signal

1) Type : R, G, B Analog  
 2) Voltage Level : 0~0.7 V  
 a) Color 0, 0 : 0 Vp-p  
 b) Color 7, 0 : 0.35 Vp-p  
 c) Color 15, 0 : 0.7 Vp-p  
 3) Input Impedance : 75  $\Omega$

3-3. Operating Frequency

Horizontal : 30 ~ 83kHz  
 Vertical : 56 ~ 75Hz

### 4. MAX. RESOLUTION

Analog : 1280 x 1024 • • • • •  
 DVI Analog/Digital : 1280 x 1024 • • • • •

### 5. POWER SUPPLY

5-1. Power Adaptor(Built-in Power)

Input : AC 100~240V, 50/60Hz, 1.0A

5-2. Power Consumption

MODE	H/V SYNC	VIDEO	POWER CONSUMPTION	LED COLOR
POWER ON (NORMAL)	ON/ON	ACTIVE	less than 53 W	GREEN
STAND-BY	OFF/ON	OFF	less than 3 W	AMBER
SUSPEND	ON/OFF	OFF	less than 3 W	AMBER
OFF	OFF/OFF	OFF	less than 3 W	AMBER
POWER OFF	-	-	less than 1 W (@120VAC)	OFF

### 6. ENVIRONMENT

6-1. Operating Temperature: 10°C~35°C (50°F~95°F) (Ambient)

6-2. Relative Humidity : 10%~80% (Non-condensing)

6-3. MTBF : 50,000 Hours(Min)  
 Lamp Life : 40,000 Hours(Min)

### 7. DIMENSIONS (with TILT/SWIVEL)

Width : 406 mm (15.98")  
 Depth : 223 mm (8.77")  
 Height : 431mm (16.97")

### 8. WEIGHT (with TILT/SWIVEL)

Net. Weight : 7.8kg (17.19 lbs)  
 Gross Weight : 10.0kg (22.04 lbs)

### 9. USB

Upstream : 1 port, Downstream : 2 port  
 Speed : Full-12Mbps, Low-1.5Mbps

## Signal Connector Pin Assignment

### • DVI-I Connector (Digital/Analog)

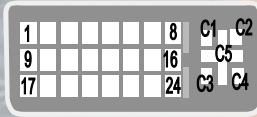

Pin	Signal (DVI-I)	Pin	Signal (DVI-I)
1	T. M. D. S. Data2-	16	Hot Plug Detect
2	T. M. D. S. Data2+	17	T. M. D. S. Data0-
3	T. M. D. S. Data2/4 Shield	18	T. M. D. S. Data0+
4	T. M. D. S. Data4-	19	T. M. D. S. Data0/5 Shield
5	T. M. D. S. Data4+	20	T. M. D. S. Data5-
6	DDC Clock	21	T. M. D. S. Data5+
7	DDC Data	22	T. M. D. S. Clock Shield
8	Analog Vertical Sync.	23	T. M. D. S. Clock+
9	T. M. D. S. Data1-	24	T. M. D. S. Clock-
10	T. M. D. S. Data1+	C1	Analog Red
11	T. M. D. S. Data1/3 Shield	C2	Analog Green
12	T. M. D. S. Data3-	C3	Analog Blue
13	T. M. D. S. Data3+	C4	Analog H. Sync.
14	+5V Power	C5	Analog Ground
15	Ground (return for +5V, H. Sync. and V. Sync.)		

T. M. D. S. (Transition Minimized Differential Signaling)

## PRECAUTION

### WARNING FOR THE SAFETY-RELATED COMPONENT.

- There are some special components used in LCD monitor that are important for safety. **These parts are marked  $\triangle$  on the schematic diagram and the replacement parts list.** It is essential that these critical parts should be replaced with the manufacturer's specified parts to prevent electric shock, fire or other hazard.
- Do not modify original design without obtaining written permission from manufacturer or you will void the original parts and labor guarantee.

### TAKE CARE DURING HANDLING THE LCD MODULE WITH BACKLIGHT UNIT.

- Must mount the module using mounting holes arranged in four corners.
- Do not press on the panel, edge of the frame strongly or electric shock as this will result in damage to the screen.
- Do not scratch or press on the panel with any sharp objects, such as pencil or pen as this may result in damage to the panel.
- Protect the module from the ESD as it may damage the electronic circuit (C-MOS).
- Make certain that treatment person's body are grounded through wrist band.
- Do not leave the module in high temperature and in areas of high humidity for a long time.
- The module not be exposed to the direct sunlight.
- Avoid contact with water as it may a short circuit within the module.
- If the surface of panel become dirty, please wipe it off with a softmaterial. (Cleaning with a dirty or rough cloth may damage the panel.)

### $\triangle$ CAUTION

Please use only a plastic screwdriver to protect yourself from shock hazard during service operation.

### $\triangle$ WARNING

#### BE CAREFUL ELECTRIC SHOCK!

- If you want to replace with the new backlight (CCFL) or inverter circuit, must disconnect the AC adapter because high voltage appears at inverter circuit about 650Vrms.
- Handle with care wires or connectors of the inverter circuit. If the wires are pressed cause short and may burn or take fire.

## TIMING CHART

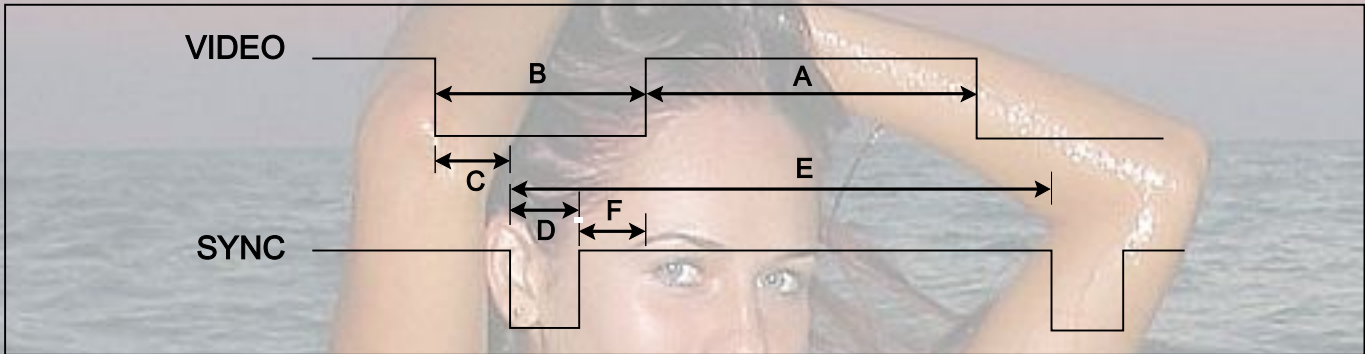

<< Dot Clock (MHz), Horizontal Frequency (kHz), Vertical Frequency (Hz), Horizontal etc... (μs), Vertical etc... (ms) >>

Mode	HV Sort	Sync Polarity	Dot Clock	Frequency	Total Period (E)	Video Active Time (A)	Front Porch (C)	Sync Duration (D)	Back Porch (F)	Resolution
1	H	+	25.175	31.469	800	640	16	96	48	640x350 70Hz
	V	-		70.8	449	350	37	2	60	
2	H	-	28.321	31.468	900	720	18	108	54	720x400 70Hz
	V	+		70.09	449	400	12	2	35	
3	H	-	25.175	31.469	800	640	16	96	48	640x480 60Hz
	V	-		59.94	525	480	10	2	33	
4	H	-	31.5	37.5	840	640	16	64	120	640x480 75Hz
	V	-		75	500	480	1	3	16	
5	H	+	40.0	37.879	1056	800	40	128	88	800x600 60Hz
	V	+		60.317	628	600	1	4	23	
6	H	+	49.5	46.875	1056	800	16	80	160	800x600 75Hz
	V	+		75.0	625	600	1	3	21	
7	H	+/-	57.283	49.725	1152	832	32	64	224	832x624 75Hz
	V	+/-		74.55	667	624	1	3	39	
8	H	-	65.0	48.363	1344	1024	24	136	160	1024x768 60Hz
	V	-		60.0	806	768	3	6	29	
9	H	-	78.75	60.123	1312	1024	16	96	176	1024x768 75Hz
	V	-		75.029	800	768	1	3	28	
10	H	+/-	100.0	68.681	1456	1152	32	128	144	1152x900 75Hz
	V	+/-		75.062	915	870	3	3	39	
11	H	+/-	92.978	61.805	1504	1152	18	134	200	1152x900 65Hz
	V	+/-		65.96	937	900	2	4	31	
12	H	+	108.0	63.981	1688	1280	48	112	248	1280x1024 60Hz
	V	+		60.02	1066	1024	1	3	38	
13	H	+	135.0	79.976	1688	1280	16	144	248	1280x1024 75Hz
	V	+		75.035	1066	1024	1	3	38	

# OPERATING INSTRUCTIONS

**FRONT VIEW**



Front Control Panel

**REAR VIEW**

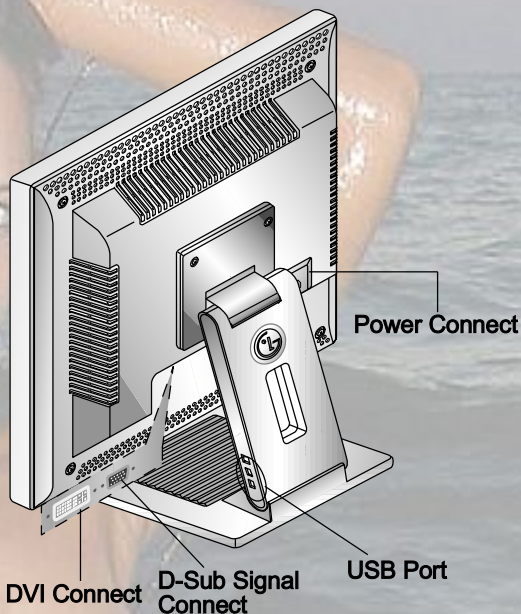

DVI Connect D-Sub Signal Connect USB Port

**Front Control Panel**



**1. Power ON/OFF Button**

Use this button to turn the monitor on or off.

**2. Power Indicator**

This indicator lights up green when the monitor operates normally. If the display is in DPM(Energy Saving)mode, this indicator color change to amber.

**3. . . . . Button**

Use these buttons to choose or adjust items in the On Screen Display.

▼ LightView ▲

This function optimizes the brightness, contrast or color value to the surrounding conditions and settings and enables you to enjoy the most suitable picture by adjusting the surroundings (DAY/NIGHT/USER MODE).

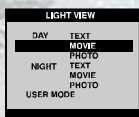

- TEXT: For viewing letters
- MOVIE: For viewing movies
- PHOTO: For viewing pictures or the photographs
- USER MODE: This function memorizes the manual adjustment -Brightness, Contrast and Color value on the On Screen Display.

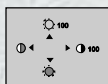

Bring up Contrast and Brightness adjustment.

◀ ◉ ▶ → ▲ ▼ → MENU

**4. MENU Button**

Use this button to enter or exit the On Screen Display.

**5. AUTO/SELECT Button**

Use this button to enter a selection in the On Screen Display.

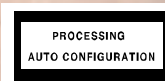

When adjusting your display settings, always press the **AUTO/SELECT** button before entering the On Screen Display(OSD). This will automatically adjust your display image to the ideal settings for the current screen resolution size(display mode). The best display mode is **1280x1024/60Hz**.

**6. SOURCE Button**

Use this button to make Dsub or DVI connector active.

This feature is used when two computers are connected to the monitor. The default setting is Dsub.

CONTROLS LOCKED

#### CONTROLS LOCKED/UNLOCKED

: MENU and ►

CONTROLS UNLOCKED

This function allows you to secure the current control settings, so that they cannot be inadvertently changed. Press and hold the MENU button and ► button for 3 seconds: the message “**CONTROLS LOCKED**” appears.

You can unlock the OSD controls at any time by pushing the MENU button and ► button for 3 seconds: the message “**CONTROLS UNLOCKED**” will appear.

### Making use of USB (Universal Serial Bus)\*

USB (Universal Serial Bus) is an innovation in connecting your different desktop peripherals conveniently to your computer. By using the USB, you will be able to connect your mouse, keyboard, and other to your monitor instead of having to connect them to your computer. This will give you greater flexibility in setting up your system. USB allows you to connect chain up to 120 devices on a single USB port, and you can “hot” plug (attach them while the computer is running) or unplug them while maintaining Plug and Play auto detection and configuration. This monitor has an integrated BUS-powered USB hub, allowing up to 2 other USB devices to be attached it.

#### USB connection

1. Connect the upstream port of the Display to the downstream port of the USB compliant PC or another hub using the USB cable. (Computer must have a USB port)
2. Connect the USB compliant peripherals to the downstream ports of the monitor.

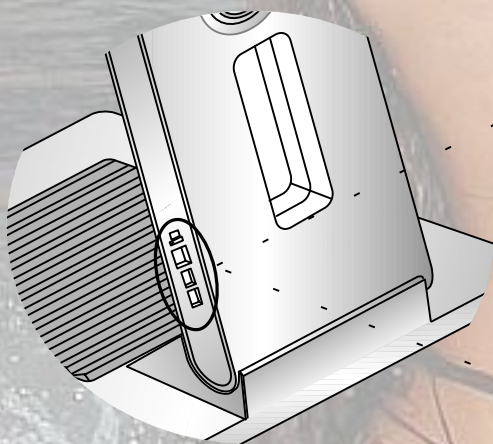

- This is a simplified representation of rear view.

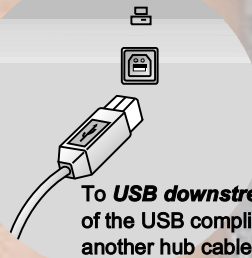

To **USB downstream port** of the USB compliant PC or another hub cable

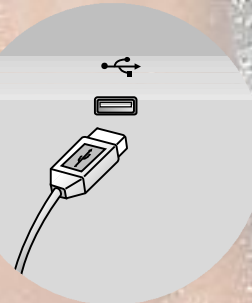

**USB downstream Port** connect the cables from USB compliant peripherals-such as keyboard, mouse, etc

#### NOTE

- To activate the USB hub function, the monitor must be connected to a USB compliant PC(OS) or another hub with the USB cable(enclosed).
- When connecting the USB cable, check that the shape of the connector at the cable side matches the shape at the connecting side.
- Even if the monitor is in a power saving mode, USB compliant devices will function when they are connected the USB ports(both the upstream and downstream) of the monitor.

# WIRING DIAGRAM

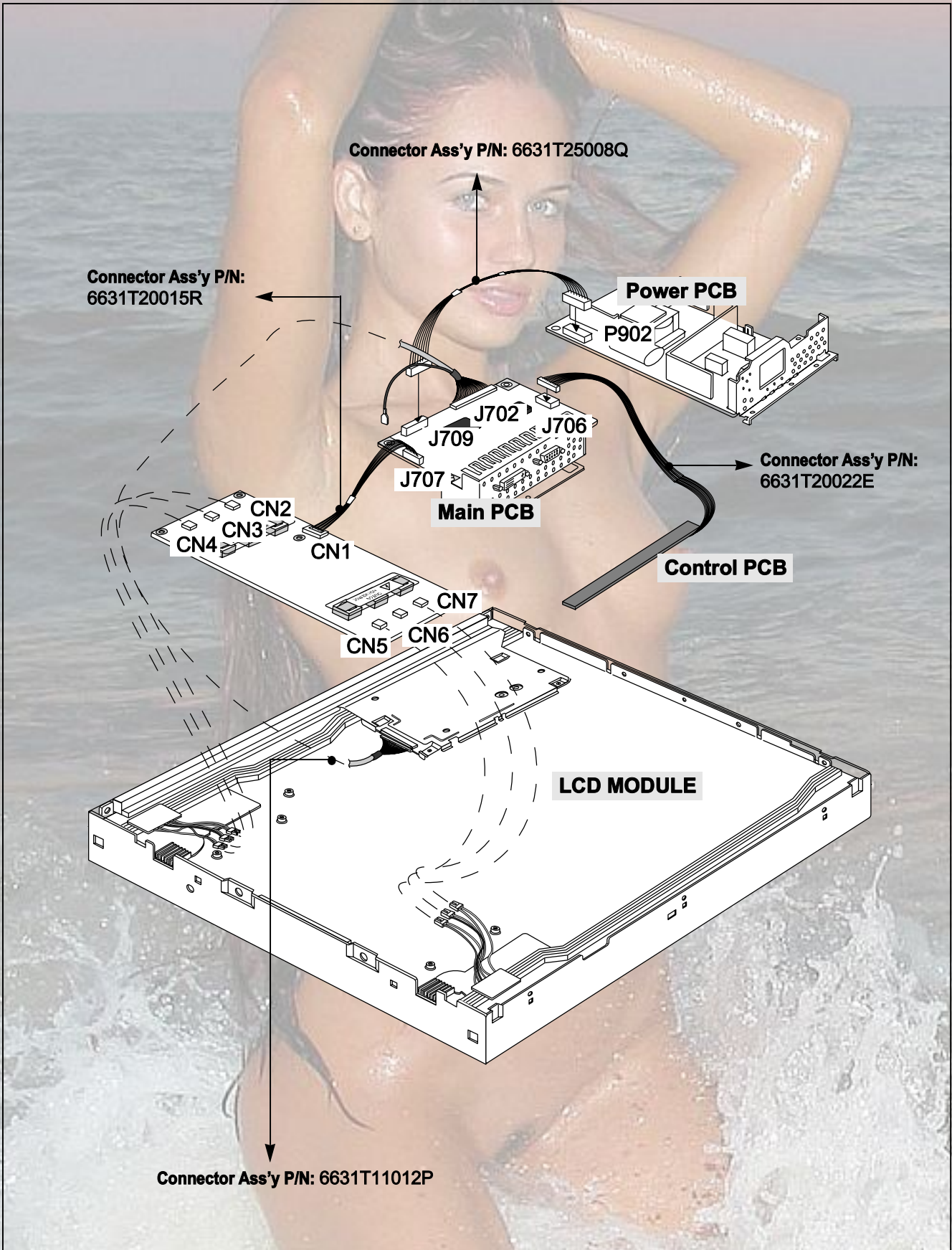



# BLOCK DIAGRAM

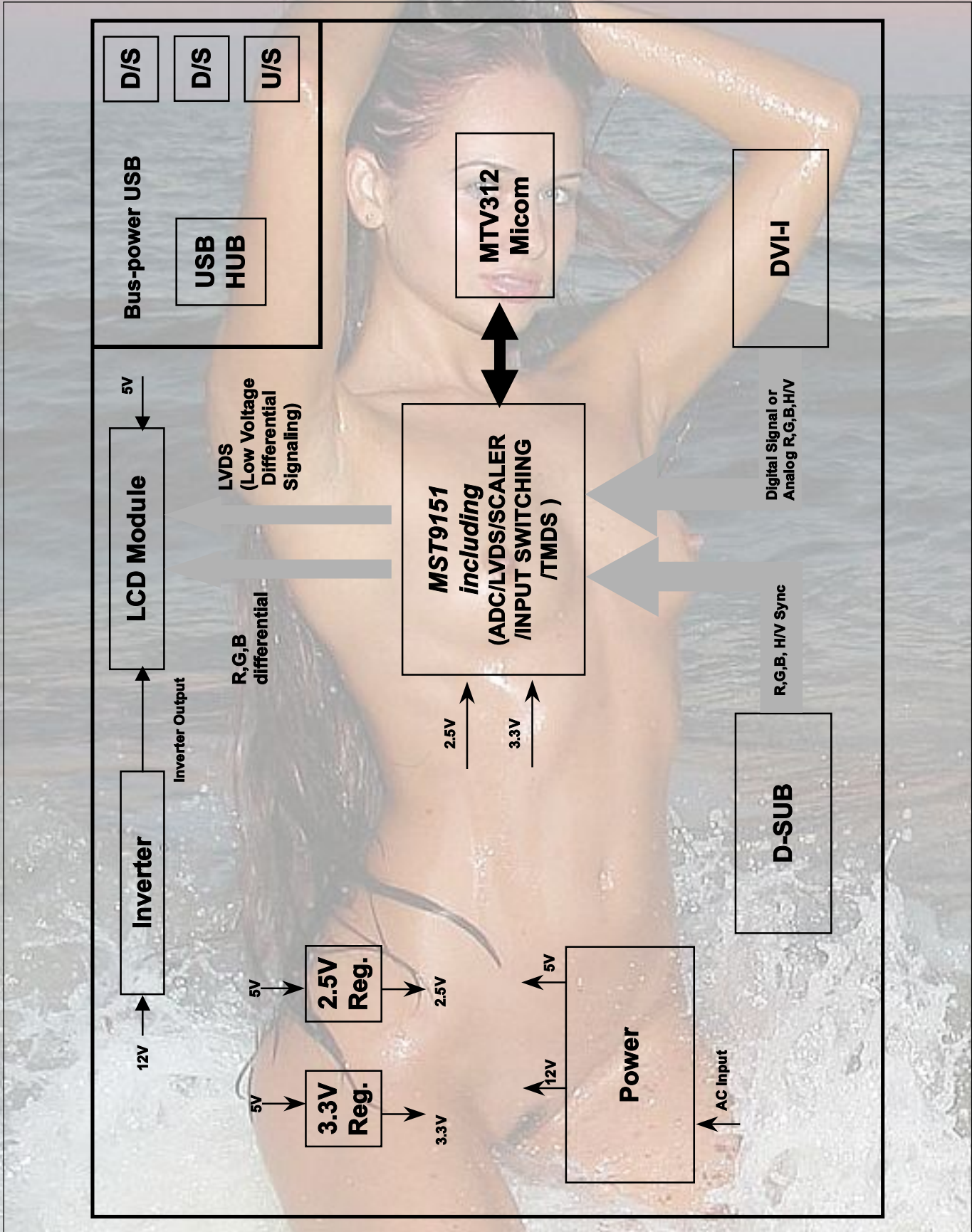

## DESCRIPTION OF BLOCK DIAGRAM

### 1. Video Controller Part & Display Data Transmitter Part.(MST9151)

This part amplifies the level of video signal for the digital conversion and converts from the analog video signal to the digital video signal using a pixel clock.

The pixel clock for each mode is generated by the PLL.

The range of the pixel clock is from 25MHz to 135MHz.

This part consists of the Scaler.

The Scaler gets the video signal converted analog to digital, interpolates input to 1280 x 1024 resolution signal and outputs 8-bit R, G, B signal to transmitter.

Especially pre-amp / ADC / Video controller/ Transmitter are merged to one chip "MST9151" by MSTAR.

This part transmit digital signal from the Scaler to the receiver of module.

### 2. Micom Part

This Part consists of EEPROM IC which stores control data, Reset IC and the Micom.

The Micom distinguishes polarity and frequency of the H/V Sync are supplied from signal cable.

The controlled data of each modes is stored in EEPROM.

### 3. Power Part

This part consists of the one 3.3V and one 2.5 regulators to convert power which is provided 5V in LIPS Board. 5V is provided for LCD Panel.

Also, 5V is converted 3.3V and 2.5V by regulator. Converted power is provided for IC in the main board.

### 4. Inverter

The inverter converts from DC12V to AC 700Vrms and operates back-light lamps of module.

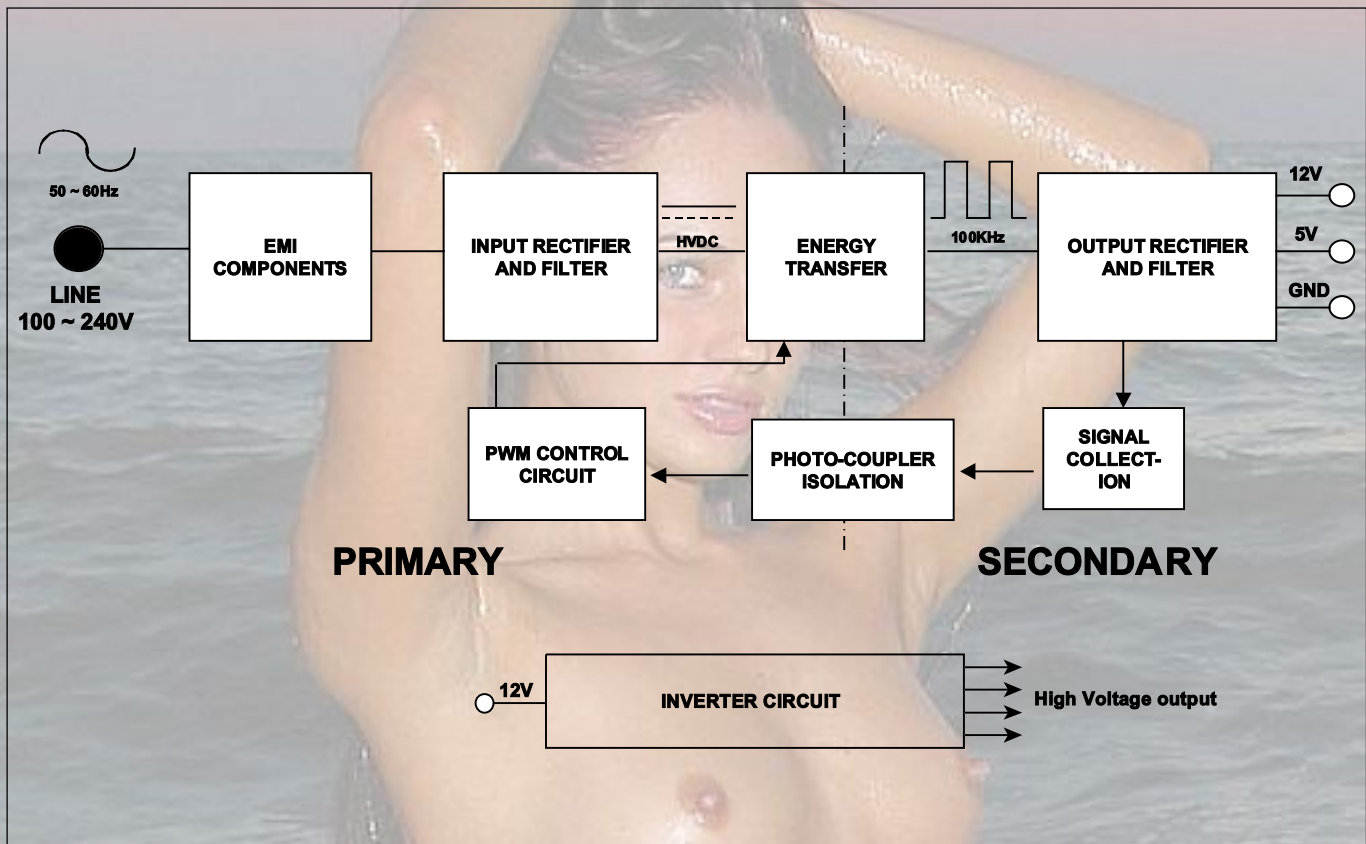

## Operation description\_Power

### 1. EMI components.

This part contains of EMI components to comply with global marketing EMI standards like FCC, VCCI CISPR, the circuit included a line-filter, across line capacitor and of course the primary protection fuse.

### 2. Input rectifier and filter.

This part function is for transfer the input AC voltage to a DC voltage through a bridge rectifier and a bulk capacitor.

### 3. Energy Transfer.

This part function is transfer the primary energy to secondary through a power transformer.

### 4. Output rectifier and filter.

This part function is to make a pulse width modulation control and to provide the driver signal to power switch, to adjust the duty cycle during different AC input and output loading condition to achive the dc output stablize, and also the over power protection is also monitor by this part.

### 5. Photo-Coupler isolation.

This part function is to feed back the dc output changing status through a photo transistor to primary controller to achieve the stabilized dc output voltage.

### 6. Signal collection.

This part function is to collect the any change from the dc output and feed back to the primary through photo transistor

# ADJUSTMENT

All adjustment are thoroughly checked and corrected when the monitor leaves the factory, but sometimes several minor adjustment may be required.

Adjustment should be following procedure and after warming up for a minimum of 10 minutes.

- Alignment appliances and tools.
  - IBM compatible PC
  - Programmable Signal Generator. (eg. VG-819 made by Astrodesign Co.)
  - E(E)PROM with each mode data saved.

## 1. Adjustment process for LCD MONITOR

- 1) Display half window pattern(or mixed white and black pattern)at Mode 8 (1024x768@60Hz).
- 2) Press the POWER and MENU key at the same time to light monitor, then go to adjustment mode.
- 3) Press the MENU s/w, next press UP button, you will see adjustment OSD menu.
- 4) Press the AUTO/SELECT to select the adjustment item first(use the same button to exit)next do the operation to the relative item.Ex) 17HYDIS is used at 17AU, press right button to select. Press the AUTO/SELECT then selected proper Module.
- 5) Press down button to move the place of ADC CAL. Press the AUTO/SELECT to select, right button is pressed for adjustment.
- 6) When adjustment is finished, press the POWER key twice to light monitor again. The dajustment ends.

## 2. Adjustment for EDID

- 1) Use this procedure only when there is some probelm on EDID data.
- 2) Connect the D-sub cable.
- 3) Select EDID → Write EDID[A0] command and Enter.

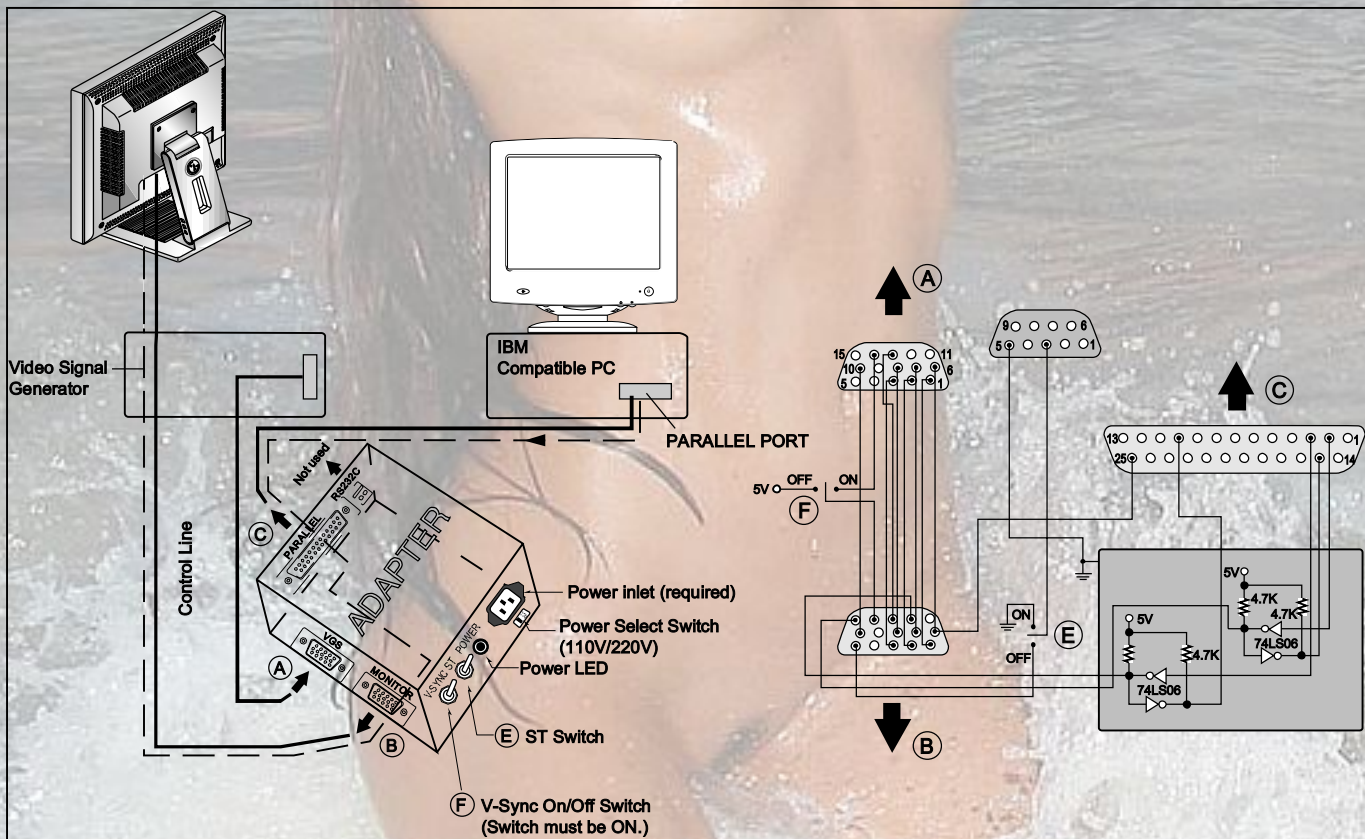
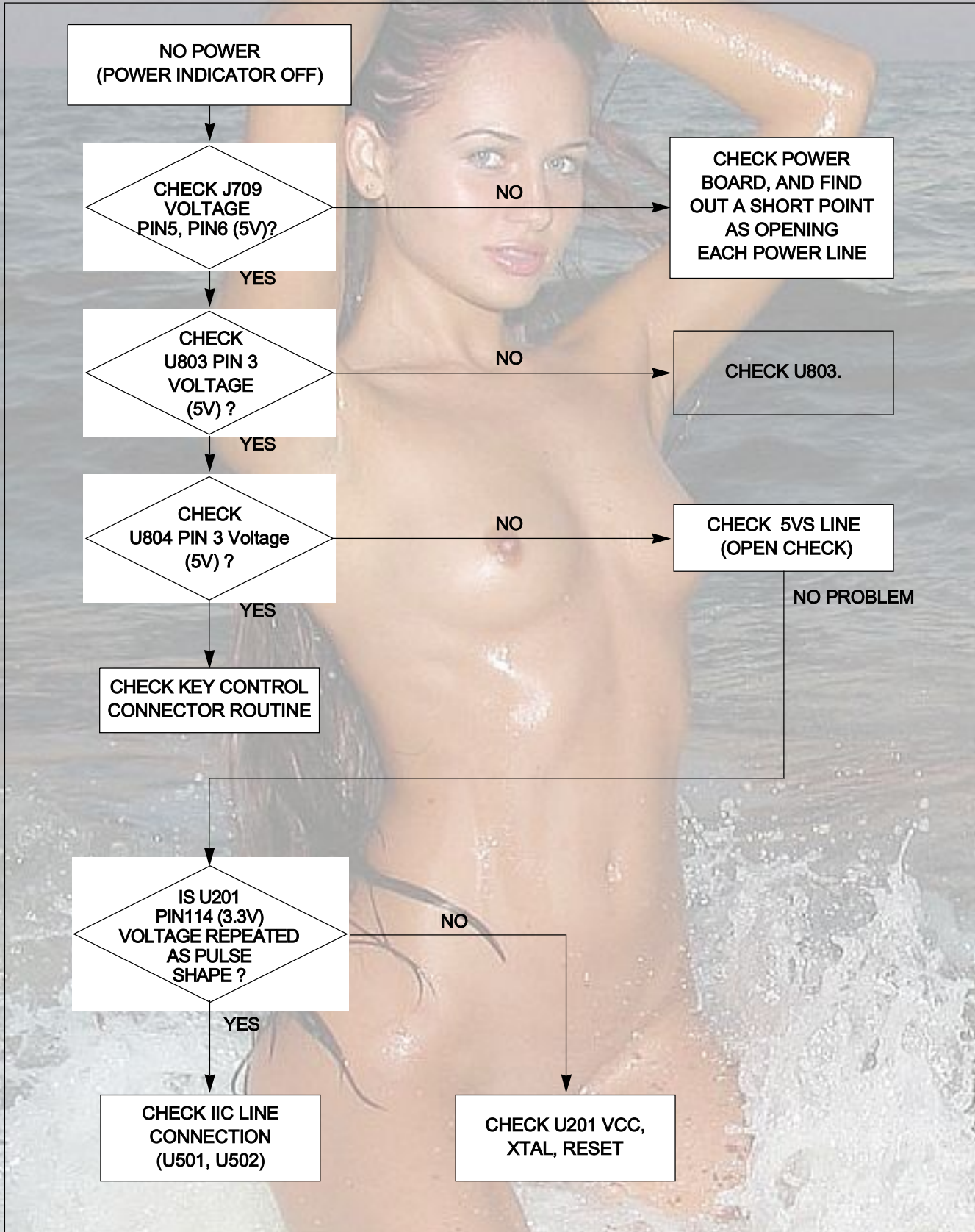

Figure 1. Cable Connection

# TROUBLESHOOTING GUIDE

## 1. NO POWER



## 2. NO RASTER (OSD IS NOT DISPLAYED) – LIPS

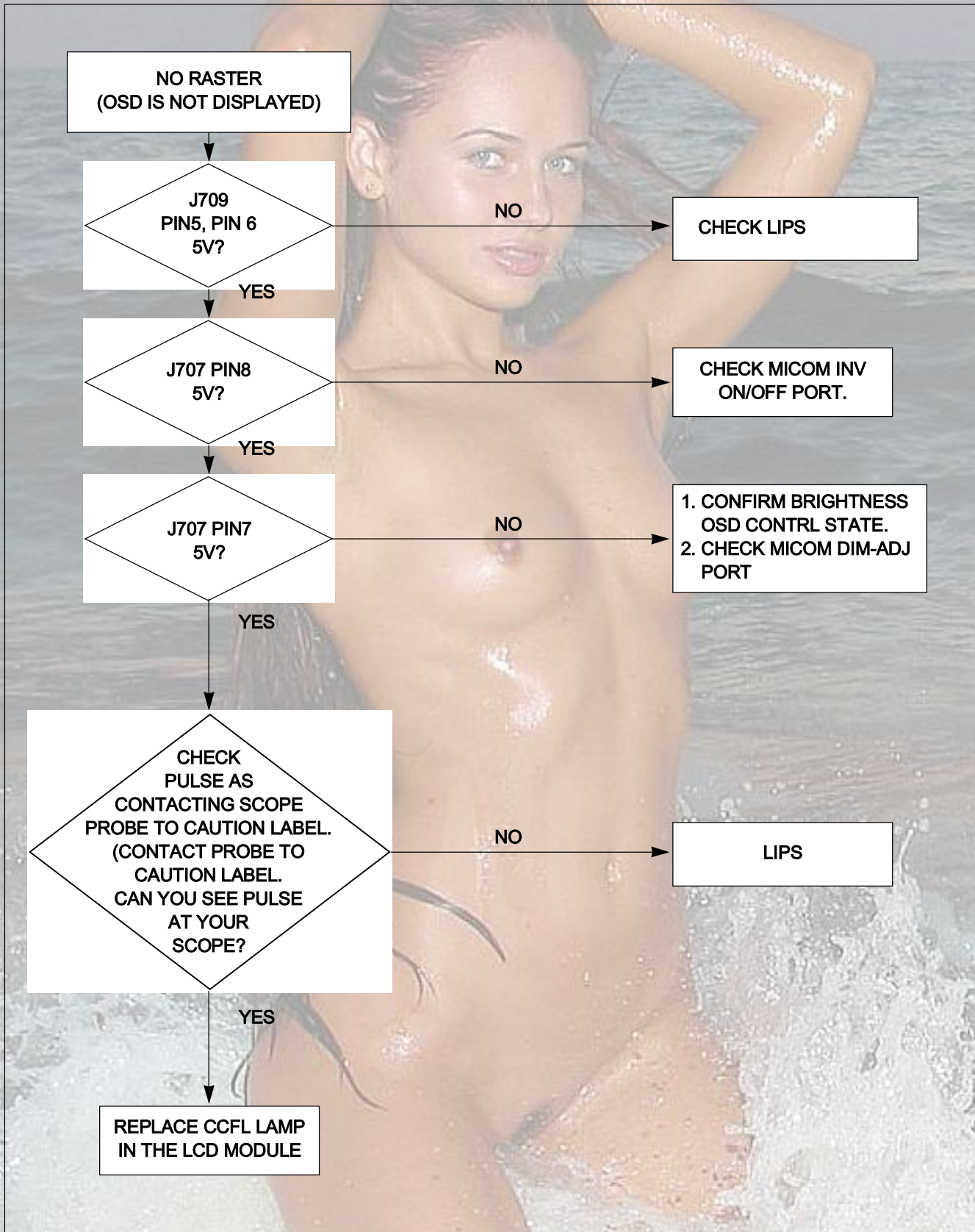

### 3. NO RASTER (OSD IS NOT DISPLAYED) – MST9151

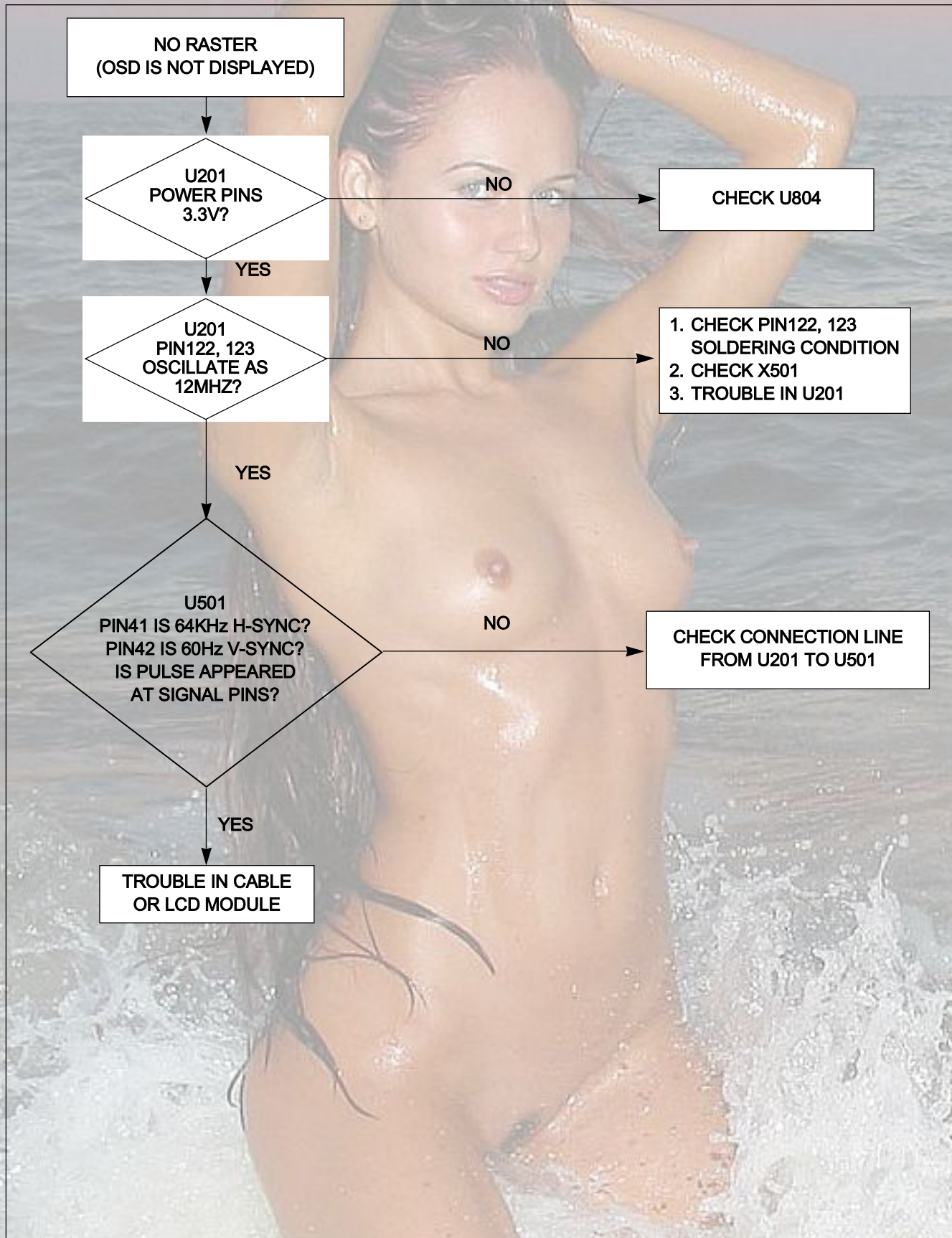

#### 4. TROUBLE IN DPM

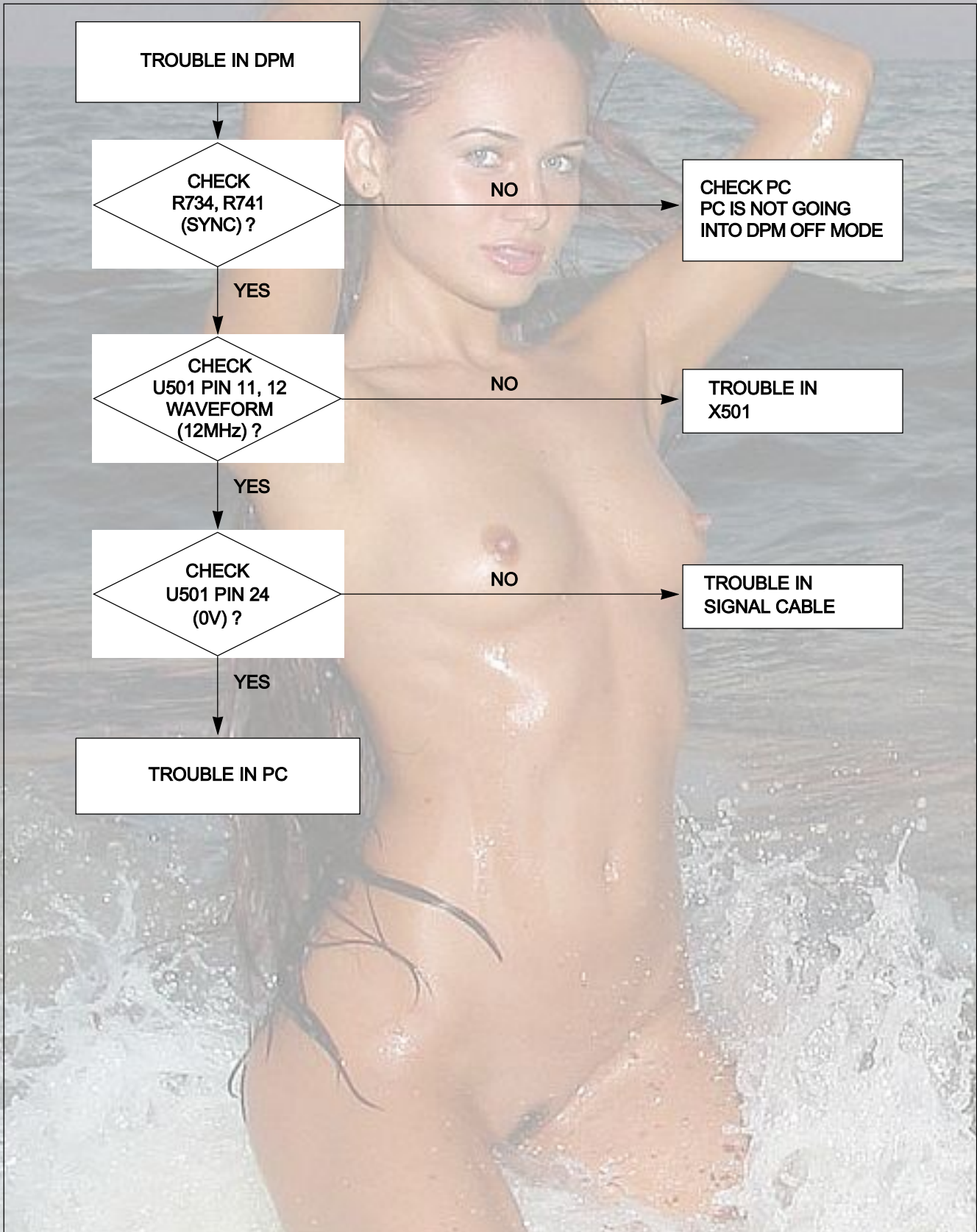



# PRINTED CIRCUIT BOARD

## 1. MAIN BOARD (Component Side)

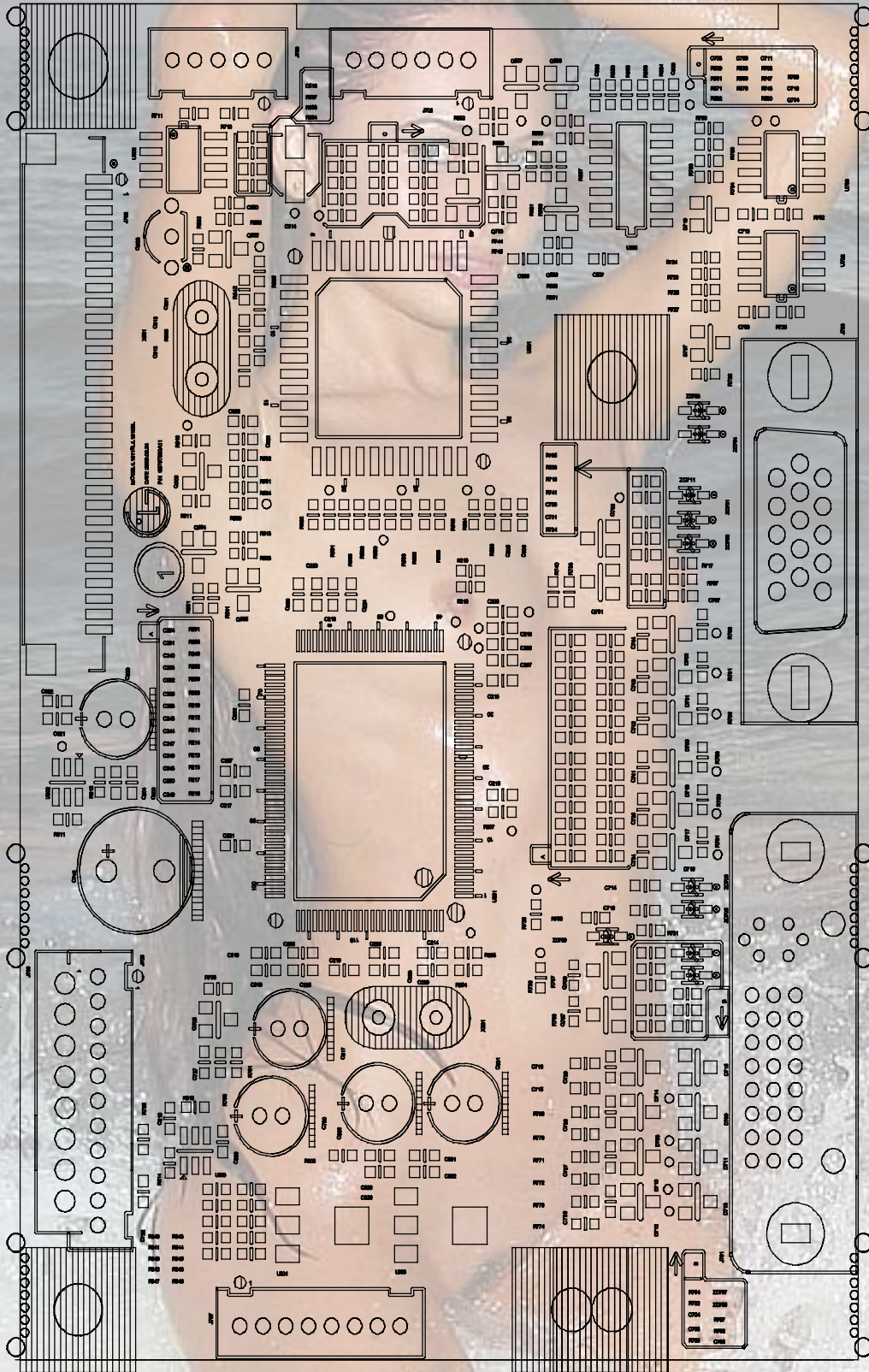

## 2. POWER BOARD (Component Side)

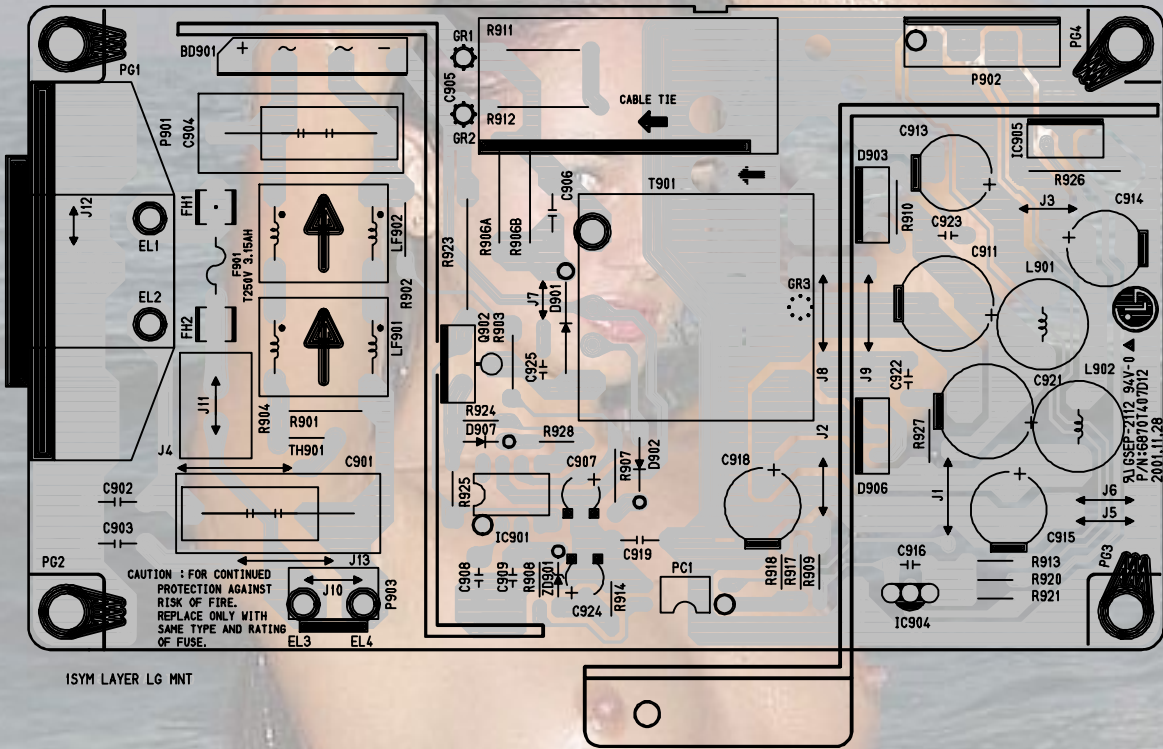

## 3. POWER BOARD (Solder Side)

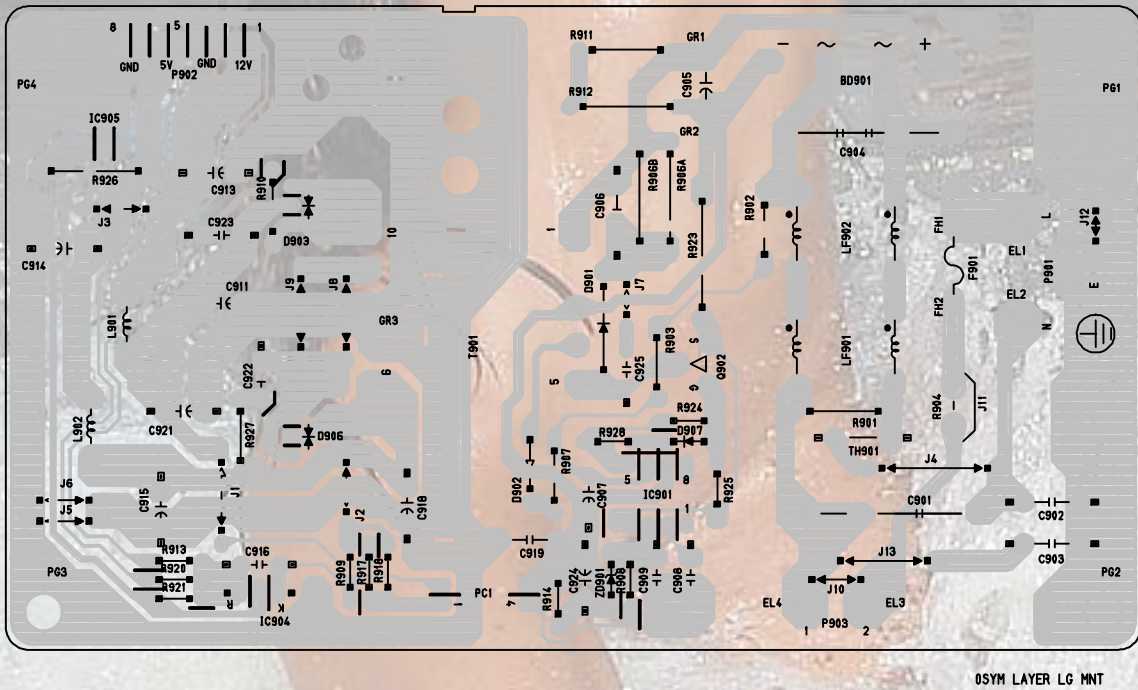

#### 4.USB BOARD (Component Side)

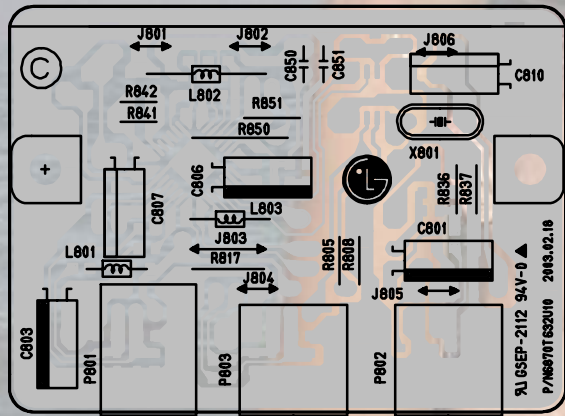

#### 5.USB BOARD (Solder Side)

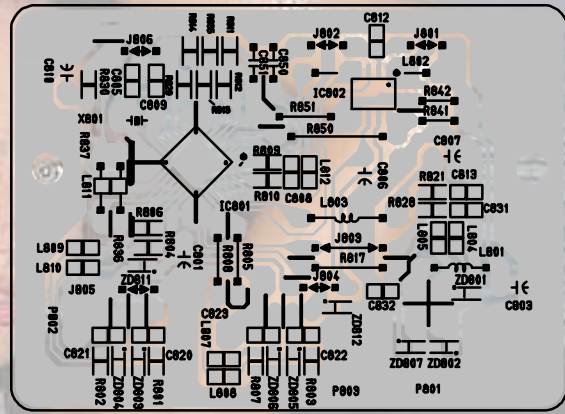

#### 6. CONTROL BOARD

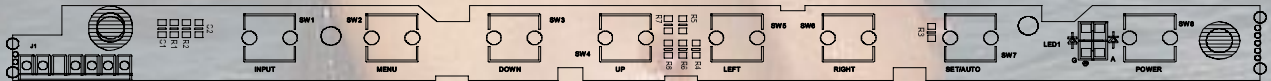

# EXPLODED VIEW

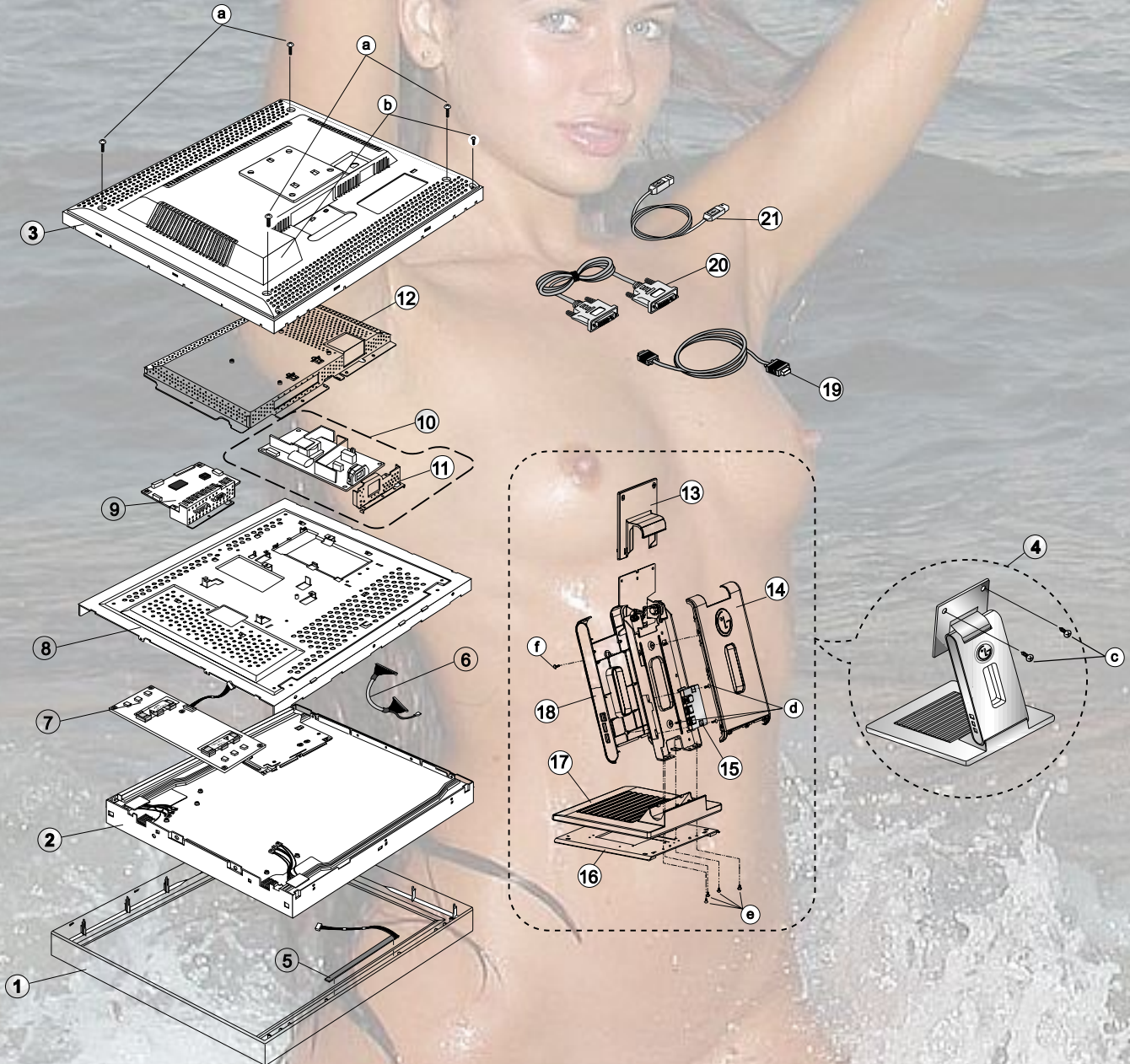

## EXPLODED VIEW PARTS LIST

\* Note: Safety mark 

Ref. No.	Part No.		Description
1	3091TKL038Q		CABINET ASSEMBLY, L1810BL BRAND , DUAL, USB
2	6304FLP034A		LCD(LIQUID CRYSTAL DISPLAY) LM181E06-A4M1 LG PHILPS TFT COLOR SXGA 18.1" LVDS SMM
	6304FLP044A		LCD(LIQUID CRYSTAL DISPLAY), LM181E06-A4C3 LG PHILPS TFT COLOR SXGA LVDS SMM
3	3809TKL025A		BACK COVER ASSEMBLY, LB800H L030A 85964
4	3043TKK091Q		TILT SWIVEL ASSEMBLY, L1810BL/L1710BL , USB
5	6871TST389A		PWB(PCB) ASSEMBLY, SUB, L1811SL L1810BL CONTROL TOTAL BRAND CONTROL
6	6631T11012P		CONNECTOR ASSEMBLY, 30P H-H 100MM UL20276 PANEL LINK LB886F
7	6633TZA008C		INVERTER ASSEMBLY, ALPS KUBNKM045A 6-LAMPS,18" DELL
8	4951TKS078X		METAL ASSEMBLY, FRAME MAIN, L1810BL/L1811SL
9	6871TMT402A		PWB(PCB) ASSEMBLY, MAIN, L1810BL ALRDR BRAND CL-42 TOTAL
10	6871TPT225A		PWB(PCB) ASSEMBLY, POWER, LB800H POWER TOTAL BRAND
11	4814TKK187A		SHIELD REAR LB886F
12	4950TKK429A		METAL REAR LB800H
13	3550TKK257A		COVER, LB800H STAND TOP HINGE 85964
14	3550TKK255A		COVER, LB800H STAND REAR 85964
15	6871TUT029A		PWB(PCB) ASSEMBLY, USB, L1710BL SUB TOTAL BRAND USB
16	4950TKK430A		METAL, STAND BASE LB800H SPCC2.0T
17	3550TKK256A		COVER, LB800H STAND BOTTOM 85964
18	3550TKK254A		COVER, LB800H STAND FRONT 85964
19	6850TD9004D		CABLE, D-SUB, UL20276-9C(5.8MM) DT 1560MM GRAY(85964) LB500L DM
20	6866TDV004C		CABLE, DVI, UL20276 DT 2000MM GRAY(85964) LB885C DM
21	6866TDU002D		CABLE, D-SUB, UL20276SB10P+2C AWG#30 DT 1870MM GRAY(85964) BRAND DM
a	1SZZTER001H		SCREW, DRAWING, D3.0 L10.0 MSWR/BK .
b	332-113S		SCREW, DRAWING, D3.0 L12.0 MSWR/BK .
c	332-105G		SCREW, DRAWING, PVS+4*10(MSWR/BK)
d	332-068U		SCREW, PPB+3x8(MSWR/FZMW1)
e	332-105K		SCREW,DRAWING, D4.0 L10.0 MSWR/FZMCW1 KNURLING
f	332-113R		SCREW, DRAWING, D3.0 L16.0 MSWR/BK

# REPLACEMENT PARTS LIST

**CAUTION:** BEFORE REPLACING ANY OF THESE COMPONENTS,  
READ CAREFULLY THE **SAFETY PRECAUTIONS** IN THIS MANUAL.

\* NOTE : **S** SAFETY Mark   
**AL** ALTERNATIVE PARTS

DATE: 2003. 3. 6.				
*S	*AL	LOC. NO.	PART NO.	DESCRIPTION / SPECIFICATION
<b>MAIN BOARD</b>				
<b>CAPACITORS</b>				
			C204	0CK104CK56A 0.1UF 1608 50V 10% R/TP X7R
			C205	0CK104CK56A 0.1UF 1608 50V 10% R/TP X7R
			C206	0CK104CK56A 0.1UF 1608 50V 10% R/TP X7R
			C207	0CK104CK56A 0.1UF 1608 50V 10% R/TP X7R
			C208	0CK104CK56A 0.1UF 1608 50V 10% R/TP X7R
			C209	0CK104CK56A 0.1UF 1608 50V 10% R/TP X7R
			C210	0CK104CK56A 0.1UF 1608 50V 10% R/TP X7R
			C214	0CK104CK56A 0.1UF 1608 50V 10% R/TP X7R
			C215	0CK104CK56A 0.1UF 1608 50V 10% R/TP X7R
			C216	0CK104CK56A 0.1UF 1608 50V 10% R/TP X7R
			C217	0CK104CK56A 0.1UF 1608 50V 10% R/TP X7R
			C218	0CK104CK56A 0.1UF 1608 50V 10% R/TP X7R
			C219	0CK104CK56A 0.1UF 1608 50V 10% R/TP X7R
			C220	0CK104CK56A 0.1UF 1608 50V 10% R/TP X7R
			C221	0CK104CK56A 0.1UF 1608 50V 10% R/TP X7R
			C222	0CK104CK56A 0.1UF 1608 50V 10% R/TP X7R
			C223	0CK104CK56A 0.1UF 1608 50V 10% R/TP X7R
			C224	0CK104CK56A 0.1UF 1608 50V 10% R/TP X7R
			C225	0CK104CK56A 0.1UF 1608 50V 10% R/TP X7R
			C226	0CK104CK56A 0.1UF 1608 50V 10% R/TP X7R
			C227	0CK104CK56A 0.1UF 1608 50V 10% R/TP X7R
			C230	0CK104CK56A 0.1UF 1608 50V 10% R/TP X7R
			C231	0CK104CK56A 0.1UF 1608 50V 10% R/TP X7R
			C232	0CK104CK56A 0.1UF 1608 50V 10% R/TP X7R
			C233	0CK104CK56A 0.1UF 1608 50V 10% R/TP X7R
			C240	0CK104CK56A 0.1UF 1608 50V 10% R/TP X7R
			C244	0CK104CK56A 0.1UF 1608 50V 10% R/TP X7R
			C245	0CK104CK56A 0.1UF 1608 50V 10% R/TP X7R
			C246	0CK104CK56A 0.1UF 1608 50V 10% R/TP X7R
			C247	0CK104CK56A 0.1UF 1608 50V 10% R/TP X7R
			C248	0CK104CK56A 0.1UF 1608 50V 10% R/TP X7R
			C249	0CK104CK56A 0.1UF 1608 50V 10% R/TP X7R
			C250	0CK104CK56A 0.1UF 1608 50V 10% R/TP X7R
			C501	0CK104CK56A 0.1UF 1608 50V 10% R/TP X7R
			C502	0CC101CK41A 100PF 1608 50V 5% R/TP NP0
			C503	0CC101CK41A 100PF 1608 50V 5% R/TP NP0
			C505	0CC101CK41A 100PF 1608 50V 5% R/TP NP0
			C506	0CC101CK41A 100PF 1608 50V 5% R/TP NP0
			C507	0CK104CK56A 0.1UF 1608 50V 10% R/TP X7R
			C508	0CC101CK41A 100PF 1608 50V 5% R/TP NP0
			C509	0CC101CK41A 100PF 1608 50V 5% R/TP NP0
			C512	0CC180CK41A 18PF 1608 50V 5% R/TP NP0
			C513	0CC030CK01A 3PF 1608 50V 0.25 PF R/TP NP
			C514	0CH8106F611 10UF 16V M 85STD(CYL) R/TP
			C516	0CK104CK56A 0.1UF 1608 50V 10% R/TP X7R
			C530	0CK103CK51A 0.01UF 1608 50V 10% R/TP B(Y)
			C703	0CK104CK56A 0.1UF 1608 50V 10% R/TP X7R
			C704	0CC101CK41A 100PF 1608 50V 5% R/TP NP0
			C705	0CC680CK41A 68PF 1608 50V 5% R/TP NP0
			C706	0CC680CK41A 68PF 1608 50V 5% R/TP NP0
			C707	0CC680CK41A 68PF 1608 50V 5% R/TP NP0
			C708	0CK103CK51A 0.01UF 1608 50V 10% R/TP B(Y)

DATE: 2003. 3. 6.				
*S	*AL	LOC. NO.	PART NO.	DESCRIPTION / SPECIFICATION
			C709	0CK103CK51A 0.01UF 1608 50V 10% R/TP B(Y)
			C710	0CK103CK51A 0.01UF 1608 50V 10% R/TP B(Y)
			C711	0CK103CK51A 0.01UF 1608 50V 10% R/TP B(Y)
			C712	0CK104CK56A 0.1UF 1608 50V 10% R/TP X7R
			C713	0CC101CK41A 100PF 1608 50V 5% R/TP NP0
			C714	0CC101CK41A 100PF 1608 50V 5% R/TP NP0
			C727	0CK105CD56A 1UF 1608 10V 10% R/TP X7R
			C730	0CC101CK41A 100PF 1608 50V 5% R/TP NP0
			C731	0CC680CK41A 68PF 1608 50V 5% R/TP NP0
			C732	0CK103CK51A 0.01UF 1608 50V 10% R/TP B(Y)
			C733	0CK104CK56A 0.1UF 1608 50V 10% R/TP X7R
			C734	0CK104CK56A 0.1UF 1608 50V 10% R/TP X7R
			C735	0CK104CK56A 0.1UF 1608 50V 10% R/TP X7R
			C737	0CK104CK56A 0.1UF 1608 50V 10% R/TP X7R
			C738	0CK104CK56A 0.1UF 1608 50V 10% R/TP X7R
			C739	0CK104CK56A 0.1UF 1608 50V 10% R/TP X7R
			C740	0CE477EH618 470UF KMG 25V M FL TP 5
			C741	0CK104CK56A 0.1UF 1608 50V 10% R/TP X7R
			C742	0CK104CK56A 0.1UF 1608 50V 10% R/TP X7R
			C743	0CK104CK56A 0.1UF 1608 50V 10% R/TP X7R
			C744	0CK104CK56A 0.1UF 1608 50V 10% R/TP X7R
			C760	0CE107EF610 "100UF KMG,RD 16V 20% FL BULK"
			C801	0CK103CK51A 0.01UF 1608 50V 10% R/TP B(Y)
			C802	0CK104CK56A 0.1UF 1608 50V 10% R/TP X7R
			C803	0CK105CD56A 1UF 1608 10V 10% R/TP X7R
			C804	0CC102CK41A 1000PF 1608 50V 5% R/TP NP0
			C809	0CK105CD56A 1UF 1608 10V 10% R/TP X7R
			C810	0CC102CK41A 1000PF 1608 50V 5% R/TP NP0
			C817	0CE107EF610 "100UF KMG,RD 16V 20% FL BULK"
			C818	0CK104CK56A 0.1UF 1608 50V 10% R/TP X7R
			C819	0CK103CK51A 0.01UF 1608 50V 10% R/TP B(Y)
			C820	0CE107EF610 "100UF KMG,RD 16V 20% FL BULK"
			C821	0CK103CK51A 0.01UF 1608 50V 10% R/TP B(Y)
			C822	0CK104CK56A 0.1UF 1608 50V 10% R/TP X7R
			C828	0CK104CK56A 0.1UF 1608 50V 10% R/TP X7R
			C829	0CK103CK51A 0.01UF 1608 50V 10% R/TP B(Y)
			C831	0CE107EF610 "100UF KMG,RD 16V 20% FL BULK"
			C832	0CE107EF610 "100UF KMG,RD 16V 20% FL BULK"
<b>DIODEs</b>				
			D701	0DS226009AA KDS226 TP KEC SOT-23 80V 30
			D702	0DS226009AA KDS226 TP KEC SOT-23 80V 30
			D706	0DS226009AA KDS226 TP KEC SOT-23 80V 30
			D707	0DD184009AA KDS184 TP KEC - 85V - - - 30
			D708	0DS226009AA KDS226 TP KEC SOT-23 80V 30
			D709	0DS226009AA KDS226 TP KEC SOT-23 80V 30
			D710	0DS226009AA KDS226 TP KEC SOT-23 80V 30
			D711	0DS226009AA KDS226 TP KEC SOT-23 80V 30
			D712	0DS226009AA KDS226 TP KEC SOT-23 80V 30
			D713	0DS226009AA KDS226 TP KEC SOT-23 80V 30
			D714	0DS226009AA KDS226 TP KEC SOT-23 80V 30
			D715	0DS226009AA KDS226 TP KEC SOT-23 80V 30
			D716	0DS226009AA KDS226 TP KEC SOT-23 80V 30

DATE: 2003. 3. 6.				
*S	*AL	LOC. NO.	PART NO.	DESCRIPTION / SPECIFICATION
		D717	0DS226009AA	KDS226 TP KEC SOT-23 80V 30
		D718	0DS226009AA	KDS226 TP KEC SOT-23 80V 30
		D719	0DD184009AA	KDS184 TP KEC - 85V --- 30
		ZD701	0DZ560009GB	BZT52C5V6S DIODES R/TP SOD32
		ZD702	0DZ560009GB	BZT52C5V6S DIODES R/TP SOD32
		ZD703	0DZ560009GB	BZT52C5V6S DIODES R/TP SOD32
		ZD704	0DZ560009GB	BZT52C5V6S DIODES R/TP SOD32
		ZD705	0DZ560009GB	BZT52C5V6S DIODES R/TP SOD32
		ZD706	0DZ560009GB	BZT52C5V6S DIODES R/TP SOD32
		ZD707	0DZ560009GB	BZT52C5V6S DIODES R/TP SOD32
		ZD708	0DZ560009GB	BZT52C5V6S DIODES R/TP SOD32
		ZD709	0DZ560009GB	BZT52C5V6S DIODES R/TP SOD32
		ZD711	0DZ560009GB	BZT52C5V6S DIODES R/TP SOD32
<b>ICs</b>				
		U201	0IPRPM3006A	MST9151 DUAL MSTAR 128P LQFP
		U501	0IZZTSZ257B	MYSON 44P PLCC ST OTP L1710S
		U502	0ISG240860B	M24C08W6 SGS-THOMSON 8SOP R/
		U503	0IPH740800H	"74F08D 14P,SOIC TP QUAD 2-IN"
		U702	0ICS240213A	CAT24WC02J-TE13 8P SOP TP 2K
		U703	0ICS240213A	CAT24WC02J-TE13 8P SOP TP 2K
		U802	0TFV180036A	SI3861DV VISHAY R/TP TSOP-6
		U803	0IPMGNS001D	LM1117MPX-2.5 NATIONAL SEMIC
		U804	0IPMGNS001E	LM1117MPX-3.3 NATIONAL SEMIC
		U805	0TFV180036A	SI3861DV VISHAY R/TP TSOP-6
<b>TRANSISTOR</b>				
		Q502	0TR390409AE	FAIRCHILD KST3904(LGEMTF) TP
		Q503	0IKE704200H	KIA7042AP TO-92 TP 4.2 VOLT
		Q504	0TR390409AE	FAIRCHILD KST3904(LGEMTF) TP
		Q505	0TR390409AE	FAIRCHILD KST3904(LGEMTF) TP
		Q506	0TR390409AE	FAIRCHILD KST3904(LGEMTF) TP
		Q507	0TR390409AE	FAIRCHILD KST3904(LGEMTF) TP
		Q508	0TR390409AE	FAIRCHILD KST3904(LGEMTF) TP
		Q509	0TR390409AE	FAIRCHILD KST3904(LGEMTF) TP
		Q701	0TR390409AE	FAIRCHILD KST3904(LGEMTF) TP
		Q702	0TR390409AE	FAIRCHILD KST3904(LGEMTF) TP
		Q703	0TR390609FA	KST3906-MTF TP SAMSUNG SOT2
		Q704	0TR390609FA	KST3906-MTF TP SAMSUNG SOT2
		Q705	0TR390409AE	FAIRCHILD KST3904(LGEMTF) TP
		Q706	0TR390409AE	FAIRCHILD KST3904(LGEMTF) TP
		Q707	0TR390409AE	FAIRCHILD KST3904(LGEMTF) TP
<b>RESISTORs</b>				
		R201	0RJ0682D677	68 OHM 1/10 W 5% 1608 R/TP
		R202	0RJ0682D677	68 OHM 1/10 W 5% 1608 R/TP
		R203	0RJ0682D677	68 OHM 1/10 W 5% 1608 R/TP
		R204	0RJ1002D677	10K OHM 1/10 W 5% 1608 R/TP
		R205	0RJ1002D677	10K OHM 1/10 W 5% 1608 R/TP
		R207	0RJ4700D677	470 OHM 1/10 W 5% 1608 R/TP
		R208	0RJ0682D677	68 OHM 1/10 W 5% 1608 R/TP
		R209	0RJ0682D677	68 OHM 1/10 W 5% 1608 R/TP
		R210	0RJ0682D677	68 OHM 1/10 W 5% 1608 R/TP
		R211	0RJ0682D677	68 OHM 1/10 W 5% 1608 R/TP
		R212	0RJ0682D677	68 OHM 1/10 W 5% 1608 R/TP
		R213	0RJ0682D677	68 OHM 1/10 W 5% 1608 R/TP
		R214	0RJ0682D677	68 OHM 1/10 W 5% 1608 R/TP
		R215	0RJ0682D677	68 OHM 1/10 W 5% 1608 R/TP
		R216	0RJ0682D677	68 OHM 1/10 W 5% 1608 R/TP

DATE: 2003. 3. 6.				
*S	*AL	LOC. NO.	PART NO.	DESCRIPTION / SPECIFICATION
		R217	0RJ0682D677	68 OHM 1/10 W 5% 1608 R/TP
		R240	0RJ0682D677	68 OHM 1/10 W 5% 1608 R/TP
		R501	0RJ4701D677	4.7K OHM 1/10 W 5% 1608 R/TP
		R502	0RJ4701D677	4.7K OHM 1/10 W 5% 1608 R/TP
		R504	0RJ4701D677	4.7K OHM 1/10 W 5% 1608 R/TP
		R509	0RJ4701D677	4.7K OHM 1/10 W 5% 1608 R/TP
		R510	0RJ4700D677	470 OHM 1/10 W 5% 1608 R/TP
		R511	0RJ4700D677	470 OHM 1/10 W 5% 1608 R/TP
		R515	0RJ1002D677	10K OHM 1/10 W 5% 1608 R/TP
		R520	0RJ4701D677	4.7K OHM 1/10 W 5% 1608 R/TP
		R522	0RJ1000D677	100 OHM 1/10 W 5% 1608 R/TP
		R523	0RJ0332D677	33 OHM 1/10 W 5% 1608 R/TP
		R524	0RJ0332D677	33 OHM 1/10 W 5% 1608 R/TP
		R525	0RJ1002D677	10K OHM 1/10 W 5% 1608 R/TP
		R528	0RJ1000D677	100 OHM 1/10 W 5% 1608 R/TP
		R529	0RJ1000D677	100 OHM 1/10 W 5% 1608 R/TP
		R530	0RJ1000D677	100 OHM 1/10 W 5% 1608 R/TP
		R531	0RJ1000D677	100 OHM 1/10 W 5% 1608 R/TP
		R532	0RJ3301D677	3.3K OHM 1/10 W 5% 1608 R/TP
		R533	0RJ0332D677	33 OHM 1/10 W 5% 1608 R/TP
		R534	0RJ0332D677	33 OHM 1/10 W 5% 1608 R/TP
		R535	0RJ3301D677	3.3K OHM 1/10 W 5% 1608 R/TP
		R537	0RJ4701D677	4.7K OHM 1/10 W 5% 1608 R/TP
		R538	0RJ4701D677	4.7K OHM 1/10 W 5% 1608 R/TP
		R540	0RJ1002D677	10K OHM 1/10 W 5% 1608 R/TP
		R541	0RJ4701D677	4.7K OHM 1/10 W 5% 1608 R/TP
		R542	0RJ1000D677	100 OHM 1/10 W 5% 1608 R/TP
		R551	0RJ4702D677	47000 OHM 1/10 W 5% 1608 R/TP
		R552	0RJ1001D677	1K OHM 1/10 W 5% 1608 R/TP
		R553	0RJ4701D677	4.7K OHM 1/10 W 5% 1608 R/TP
		R554	0RJ4701D677	4.7K OHM 1/10 W 5% 1608 R/TP
		R555	0RJ4701D677	4.7K OHM 1/10 W 5% 1608 R/TP
		R556	0RJ4701D677	4.7K OHM 1/10 W 5% 1608 R/TP
		R557	0RJ1001D677	1K OHM 1/10 W 5% 1608 R/TP
		R558	0RJ4701D677	4.7K OHM 1/10 W 5% 1608 R/TP
		R559	0RJ1001D677	1K OHM 1/10 W 5% 1608 R/TP
		R560	0RJ4701D677	4.7K OHM 1/10 W 5% 1608 R/TP
		R561	0RJ1000D677	100 OHM 1/10 W 5% 1608 R/TP
		R562	0RJ4700D677	470 OHM 1/10 W 5% 1608 R/TP
		R570	0RJ1001D677	1K OHM 1/10 W 5% 1608 R/TP
		R580	0RJ1001D677	1K OHM 1/10 W 5% 1608 R/TP
		R590	0RJ1000D677	100 OHM 1/10 W 5% 1608 R/TP
		R591	0RJ1000D677	100 OHM 1/10 W 5% 1608 R/TP
		R592	0RJ1000D677	100 OHM 1/10 W 5% 1608 R/TP
		R593	0RJ1000D677	100 OHM 1/10 W 5% 1608 R/TP
		R595	0RJ1000D677	100 OHM 1/10 W 5% 1608 R/TP
		R596	0RJ4701D677	4.7K OHM 1/10 W 5% 1608 R/TP
		R701	0RJ0752D677	75 OHM 1/10 W 5% 1608 R/TP
		R703	0RJ0752D677	75 OHM 1/10 W 5% 1608 R/TP
		R705	0RJ1000D677	100 OHM 1/10 W 5% 1608 R/TP
		R706	0RJ0752D677	75 OHM 1/10 W 5% 1608 R/TP
		R707	0RJ0272D677	27 OHM 1/10 W 5% 1608 R/TP
		R708	0RJ4700D677	470 OHM 1/10 W 5% 1608 R/TP
		R709	0RJ4700D677	470 OHM 1/10 W 5% 1608 R/TP
		R716	0RJ4701D677	4.7K OHM 1/10 W 5% 1608 R/TP
		R717	0RJ4701D677	4.7K OHM 1/10 W 5% 1608 R/TP
		R722	0RJ1000D677	100 OHM 1/10 W 5% 1608 R/TP
		R723	0RJ0332D677	33 OHM 1/10 W 5% 1608 R/TP
		R724	0RJ0332D677	33 OHM 1/10 W 5% 1608 R/TP
		R725	0RJ4701D677	4.7K OHM 1/10 W 5% 1608 R/TP
		R726	0RJ1002D677	10K OHM 1/10 W 5% 1608 R/TP
		R727	0RJ1002D677	10K OHM 1/10 W 5% 1608 R/TP

DATE: 2003. 3. 6.				
*S	*AL	LOC. NO.	PART NO.	DESCRIPTION / SPECIFICATION
		R728	0RJ0222D677	22 OHM 1/10 W 5% 1608 R/TP
		R729	0RJ0222D677	22 OHM 1/10 W 5% 1608 R/TP
		R730	0RJ1000D677	100 OHM 1/10 W 5% 1608 R/TP
		R731	0RJ4700D677	470 OHM 1/10 W 5% 1608 R/TP
		R732	0RJ4701D677	4.7K OHM 1/10 W 5% 1608 R/TP
		R733	0RJ1001D677	1K OHM 1/10 W 5% 1608 R/TP
		R734	0RJ4701D677	4.7K OHM 1/10 W 5% 1608 R/TP
		R735	0RJ0000D677	0 OHM 1/10 W 5% 1608 R/TP
		R740	0RJ1001D677	1K OHM 1/10 W 5% 1608 R/TP
		R741	0RJ4701D677	4.7K OHM 1/10 W 5% 1608 R/TP
		R744	0RJ4701D677	4.7K OHM 1/10 W 5% 1608 R/TP
		R745	0RJ4701D677	4.7K OHM 1/10 W 5% 1608 R/TP
		R747	0RJ4701D677	4.7K OHM 1/10 W 5% 1608 R/TP
		R748	0RJ4701D677	4.7K OHM 1/10 W 5% 1608 R/TP
		R750	0RJ1001D677	1K OHM 1/10 W 5% 1608 R/TP
		R751	0RJ1001D677	1K OHM 1/10 W 5% 1608 R/TP
		R753	0RJ1001D677	1K OHM 1/10 W 5% 1608 R/TP
		R754	0RJ4701D677	4.7K OHM 1/10 W 5% 1608 R/TP
		R755	0RJ4701D677	4.7K OHM 1/10 W 5% 1608 R/TP
		R756	0RJ0272D677	27 OHM 1/10 W 5% 1608 R/TP
		R757	0RJ4701D677	4.7K OHM 1/10 W 5% 1608 R/TP
		R758	0RJ0752D677	75 OHM 1/10 W 5% 1608 R/TP
		R759	0RJ0752D677	75 OHM 1/10 W 5% 1608 R/TP
		R761	0RJ0752D677	75 OHM 1/10 W 5% 1608 R/TP
		R762	0RJ4701D677	4.7K OHM 1/10 W 5% 1608 R/TP
		R763	0RJ1002D677	10K OHM 1/10 W 5% 1608 R/TP
		R764	0RJ1002D677	10K OHM 1/10 W 5% 1608 R/TP
		R765	0RJ0332D677	33 OHM 1/10 W 5% 1608 R/TP
		R766	0RJ0332D677	33 OHM 1/10 W 5% 1608 R/TP
		R767	0RJ1001D677	1K OHM 1/10 W 5% 1608 R/TP
		R768	0RJ1001D677	1K OHM 1/10 W 5% 1608 R/TP
		R769	0RJ0102D677	10 OHM 1/10 W 5% 1608 R/TP
		R770	0RJ0102D677	10 OHM 1/10 W 5% 1608 R/TP
		R771	0RJ0102D677	10 OHM 1/10 W 5% 1608 R/TP
		R772	0RJ0102D677	10 OHM 1/10 W 5% 1608 R/TP
		R773	0RJ0102D677	10 OHM 1/10 W 5% 1608 R/TP
		R774	0RJ0102D677	10 OHM 1/10 W 5% 1608 R/TP
		R803	0RJ0000D677	0 OHM 1/10 W 5% 1608 R/TP
		R811	0RJ2202D677	22K OHM 1/10 W 5% 1608 R/TP
		R812	0RJ5600D677	560 OHM 1/10 W 5% 1608 R/TP
		R813	0RJ2202D677	22K OHM 1/10 W 5% 1608 R/TP
		R814	0RJ5600D677	560 OHM 1/10 W 5% 1608 R/TP
		R840	0RJ0332D677	33 OHM 1/10 W 5% 1608 R/TP
		R841	0RJ0332D677	33 OHM 1/10 W 5% 1608 R/TP
		R842	0RJ0332D677	33 OHM 1/10 W 5% 1608 R/TP
		R843	0RJ0332D677	33 OHM 1/10 W 5% 1608 R/TP
		R844	0RJ0332D677	33 OHM 1/10 W 5% 1608 R/TP
		R845	0RJ0332D677	33 OHM 1/10 W 5% 1608 R/TP
		R846	0RJ0332D677	33 OHM 1/10 W 5% 1608 R/TP
		R847	0RJ0332D677	33 OHM 1/10 W 5% 1608 R/TP
		R848	0RJ0332D677	33 OHM 1/10 W 5% 1608 R/TP
		R849	0RJ0332D677	33 OHM 1/10 W 5% 1608 R/TP
<b>OTHERs</b>				
		X501	6212AA2004A	HC-49U TXC 12.0MHZ +/- 30 PP
<b>POWER BOARD</b>				
		BD901	0DD360000DA	D3SBA60 BK SHINDENGEN 600V
		C901	0CBZTBU002B	BULK PCX2 335 474K
		C902	0CKZTBU006B	NK E 332M 250V BK10.0 DA2GYE

DATE: 2003. 3. 6.				
*S	*AL	LOC. NO.	PART NO.	DESCRIPTION / SPECIFICATION
			C903	0CKZTBU006B NK E 332M 250V BK10.0 DA2GYE
			C904	0CBZTBU002A BULK PCX2 335 224K
			C905	0CZZTAB002C KMF 18*40 SYE / SWE 400V 120
			C906	0CK10302945 0.01UF 2KV Z F TR
			C907	0CE476EK638 47UF KMG 50V M FM5 TP 5
			C908	0CQ2721N419 2700PF 100V J PE NI TP
			C909	0CK1020K515 1000PF 50V K B TR
			C911	0CE228EF630 2200UF KMG 16V M FM5 BULK
			C913	0CE108BF630 1000UF KME 16V M FM5 BULK
			C914	0CE228ED630 *2200UF KMG,RD 10V 20% BULK F*
			C915	0CE228ED630 *2200UF KMG,RD 10V 20% BULK F*
			C916	181-288L MKT 100V 823JTR PHS26823
			C918	0CE228ED630 *2200UF KMG,RD 10V 20% BULK F*
			C919	0CKZTBU006B NK E 332M 250V BK10.0 DA2GYE
			C921	0CE228EF630 2200UF KMG 16V M FM5 BULK
			C922	0CKZTTA002E EKR3A102K09FK5 SAMWHA 1KV 10
			C923	0CKZTTA002E EKR3A102K09FK5 SAMWHA 1KV 10
			C924	0CE336BH638 33UF KME 25V M FM5 TP5
			D901	0DD400709CB UF4007 TP G.I DO204AL 1000V
			D902	0DR400409AB UF4004 TP G.I DO204AL 400V 1
			D903	0DRIR00011B 16CTQ100 I.R ST TO220 100V 1
			D906	0DRIR00021A 30CTQ060 I.R ST TO220 60V 30
			D907	0DS113309AA 1SS133 TP ROHM KOREA DO34 90
			F901	0FZZTTH001D *TIME LAG HBC 3.15A/250V,215*
			FH1	430-858C AFC-520 BAE EUN TA
			FH2	430-858C AFC-520 BAE EUN TA
			IC901	0IPMGIH001A *ICE2AS01 INFINEON 8P,DIP ST*
			IC904	0ISS431000A KA431AZ (LM431AZ)
			IC905	0ISS780500F KA7805
			L901	150-A85F *LX31 GET BAR CHOKE,3.3UH,LB8*
			L902	150-A85F *LX31 GET BAR CHOKE,3.3UH,LB8*
			LF901	6200TZ001A *- GO BK L/FILTER,9MH,LB886F*
			LF902	6200TZ001A *- GO BK L/FILTER,9MH,LB886F*
			P901	6620TKB002A BAE EUN AC UNIVERSAL 3PIN BL
			PC1	0IL817000E LTV-817M-V(B) 4P BK PHOTO C
			Q902	0TFFN10004A INFINEON SPP11N60C2 ST TO220
			R901	0RD6803A609 680K OHM 1/2 W (7.0) 5% TA52
			R902	0RD3902A609 39K OHM 1/2 W (7.0) 5% TA52
			R903	0RD3902A609 39K OHM 1/2 W (7.0) 5% TA52
			R906A	0RX5102J609 51KOHM 1 W 5% TA52
			R906B	0RX5102J609 51KOHM 1 W 5% TA52
			R907	0RD0102Q609 10 1/4W(3 5% TA52
			R908	0RD0222Q609 22 1/4W(3 5% TA52
			R909	0RD1001Q609 1K 1/4W(3 5% TA52
			R910	0RD0431A609 4.3 OHM 1/2 W (7.0) 5% TA52
			R911	0RD1004A609 1.0M OHM 1/2 W (7.0) 5% TA52
			R912	0RD1004A609 1.0M OHM 1/2 W (7.0) 5% TA52
			R913	0RN1102F409 11K 1/6W 1% TA52
			R914	0RD1002Q609 10K 1/4W(3 5% TA52
			R917	0RD1201Q609 1.20K 1/4W(3 5% TA52
			R918	0RD1000Q609 100 1/4W(3 5% TA52
			R920	0RN4702F409 47K 1/6W 1% TA52
			R921	0RN2701F409 2.7K OHM 1/6 W 1.00% TA52
			R923	0RB0330K607 0.33 OHM 2 W 5% TA62
			R924	0RD0752Q609 75 1/4W(3 5% TA52
			R925	0RD1002Q609 10K 1/4W(3 5% TA52
			R926	0RN0471H609 4.7 OHM 1/2 W 5% TA52
			R927	0RD0102A609 10 OHM 1/2 W (7.0) 5% TA52
			R928	0RD0202Q609 20 1/4W(3 5% TA52
			T901	6170TMZ125B EER3016 340UH V-10PIN LB886F
			TH902	6322TA080AA TP8D13 DAEWOO +/- 15% 110/2
			ZD901	0DZ470009BC GDZ4.7B TP GRANDE DO34 0.5W



DATE: 2003. 3. 6.			
*S	*AL	LOC. NO.	PART NO. DESCRIPTION / SPECIFICATION
<b>CONTROL BOARD</b>			
		LED1	0DLLT0208AA LITEON LTST-C155KGJSKT R/TP
		R1	0RJ4701D677 4.7K OHM 1/10 W 5% 1608 R/TP
		R2	0RJ4701D677 4.7K OHM 1/10 W 5% 1608 R/TP
		R3	0RJ8200D677 820 OHM 1/10 W 5% 1608 R/TP
		R4	0RJ8200D677 820 OHM 1/10 W 5% 1608 R/TP
		R5	0RJ1501D677 1.5K OHM 1/10 W 5% 1608 R/TP
		R6	0RJ1501D677 1.5K OHM 1/10 W 5% 1608 R/TP
		R7	0RJ2201D677 2200 OHM 1/10 W 5% 1608 R/TP
		R8	0RJ2201D677 2200 OHM 1/10 W 5% 1608 R/TP
		SW1	140-058E SKHV10910B LGEC NON 12V 20A
		SW2	140-058E SKHV10910B LGEC NON 12V 20A
		SW3	140-058E SKHV10910B LGEC NON 12V 20A
		SW4	140-058E SKHV10910B LGEC NON 12V 20A
		SW5	140-058E SKHV10910B LGEC NON 12V 20A
		SW6	140-058E SKHV10910B LGEC NON 12V 20A
		SW7	140-058E SKHV10910B LGEC NON 12V 20A
		SW8	140-058E SKHV10910B LGEC NON 12V 20A
<b>USB BOARD</b>			
		C801	0CE107EF638 100UF KMG 16V M FM5 TP 5
		C803	0CE107EF638 100UF KMG 16V M FM5 TP 5
		C805	0CH6330K416 33PF 50V J NP0 2012 R/TP
		C806	0CE107EF638 100UF KMG 16V M FM5 TP 5
		C807	0CE105CK638 "1UF SHL,SD 50V 20% FM5 TP 5"
		C808	0CH3103K516 10000PF 50V K B 2012 R/TP
		C809	0CH6330K416 33PF 50V J NP0 2012 R/TP
		C810	0CE105CK638 "1UF SHL,SD 50V 20% FM5 TP 5"
		C812	0CH3103K516 10000PF 50V K B 2012 R/TP
		C813	0CH3103K516 10000PF 50V K B 2012 R/TP
		C820	0CH6470K416 47PF 50V 5% NP0 2012 R/TP
		C821	0CH6470K416 47PF 50V 5% NP0 2012 R/TP
		C822	0CH6470K416 47PF 50V 5% NP0 2012 R/TP
		C823	0CH6470K416 47PF 50V 5% NP0 2012 R/TP
		C831	0CH6470K416 47PF 50V 5% NP0 2012 R/TP
		C832	0CH6470K416 47PF 50V 5% NP0 2012 R/TP
		C850	0CN1040K949 0.1M 50V Z F TA52
		C851	0CN1040K949 0.1M 50V Z F TA52
		IC801	0IPH112200C "ISP1122ABD 32P,LQFP R/TP USB"
		IC802	0ITI204200B TPS2042ADR TEXAS INSTRUMENT
		L801	125-155J BFS2550A0FG SAMWHA 2.5*5.0MM
		L802	125-155J BFS2550A0FG SAMWHA 2.5*5.0MM
		L803	125-155J BFS2550A0FG SAMWHA 2.5*5.0MM
		L804	6210TCE001H HB-1T2012-301JT CERATEC 2012
		L805	6210TCE001H HB-1T2012-301JT CERATEC 2012
		L807	6210TCE001H HB-1T2012-301JT CERATEC 2012
		L808	6210TCE001H HB-1T2012-301JT CERATEC 2012
		L809	6210TCE001H HB-1T2012-301JT CERATEC 2012
		L810	6210TCE001H HB-1T2012-301JT CERATEC 2012
		L811	6210TCE001H HB-1T2012-301JT CERATEC 2012
		L812	6210TCE001H HB-1T2012-301JT CERATEC 2012
		R801	0RH1502D622 15K 1/10W 5 D.R/TP
		R802	0RH1502D622 15K 1/10W 5 D.R/TP
		R803	0RH1502D622 15K 1/10W 5 D.R/TP
		R804	0RH0222D622 22 1/10W 5 D.R/TP
		R805	0RD0222Q609 22 1/4W(3 5% TA52
		R806	0RH0222D622 22 1/10W 5 D.R/TP
		R807	0RH1502D622 15K 1/10W 5 D.R/TP
		R808	0RD0222Q609 22 1/4W(3 5% TA52
		R809	0RH1004D622 1.0M 1/10W 5 D.R/TP
		R810	0RH1004D622 1.0M 1/10W 5 D.R/TP

DATE: 2003. 3. 6.			
*S	*AL	LOC. NO.	PART NO. DESCRIPTION / SPECIFICATION
		R811	0RH1003D622 100K 1/10W 5 D.R/TP
		R812	0RH1003D622 100K 1/10W 5 D.R/TP
		R813	0RH1004D622 1.0M 1/10W 5 D.R/TP
		R814	0RH1004D622 1.0M 1/10W 5 D.R/TP
		R817	0RD0222Q609 22 1/4W(3 5% TA52
		R821	0RH1501D622 1.5K OHM 1 / 10 W 2012 5.00%
		R828	0RH0222D622 22 1/10W 5 D.R/TP
		R829	0RH1002D622 10K OHM 1 / 10 W 2012 5.00%
		R830	0RH1002D622 10K OHM 1 / 10 W 2012 5.00%
		R835	0RH1003D622 100K 1/10W 5 D.R/TP
		R836	0RD1004Q609 1M OHM 1/4 W (3.4) 5% TA52
		R837	0RD3301Q509 3.3K OHM 1/4 W (3.4) 2% TA52
		R841	0RD1502Q609 15K 1/4W(3 5% TA52
		R842	0RD1502Q609 15K 1/4W(3 5% TA52
		R850	0RD1502Q609 15K 1/4W(3 5% TA52
		R851	0RD1502Q609 15K 1/4W(3 5% TA52
		X801	6202TTB002B ATS-49U SUNNY RADIAL 6MHZ 3
		ZD801	0DZ510009EE UDZ S 5.1B TP ROHM-K SOD323
		ZD802	0DZ510009EE UDZ S 5.1B TP ROHM-K SOD323
		ZD803	0DZ510009EE UDZ S 5.1B TP ROHM-K SOD323
		ZD804	0DZ510009EE UDZ S 5.1B TP ROHM-K SOD323
		ZD805	0DZ510009EE UDZ S 5.1B TP ROHM-K SOD323
		ZD806	0DZ510009EE UDZ S 5.1B TP ROHM-K SOD323
		ZD807	0DZ560009DA UDZ S 5.6B TP ROHM-K SOD323
		ZD811	0DZ560009DA UDZ S 5.6B TP ROHM-K SOD323
		ZD812	0DZ560009DA UDZ S 5.6B TP ROHM-K SOD323

# PIN CONFIGURATION

## MST9151 DUAL MSTAR 128P



# CAT24WC08J-TE13 8P

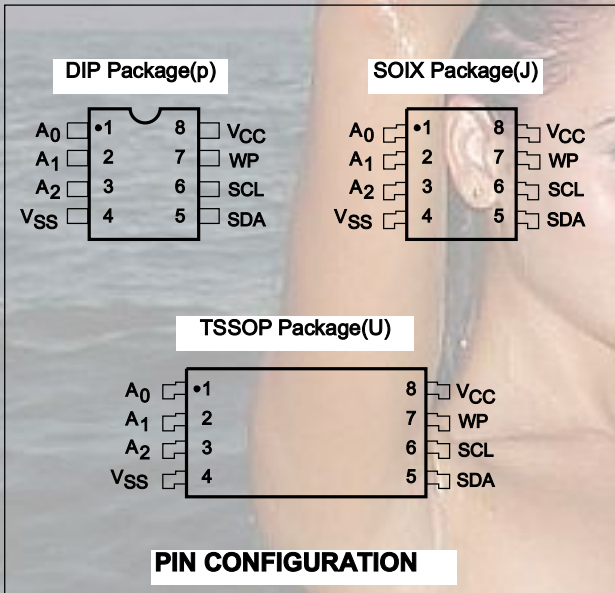

## PIN CONFIGURATION

## PIN FUNCTION

Pin Name	Function
A0, A1, A2	Device Address Inputs
SDA	Serial Data/Address
SCL	Serial Clock
WP	Write Protect
Vcc	+1.8V to + 6.0V power Supply
Vss	Ground

## BLOCK DIAGRAM

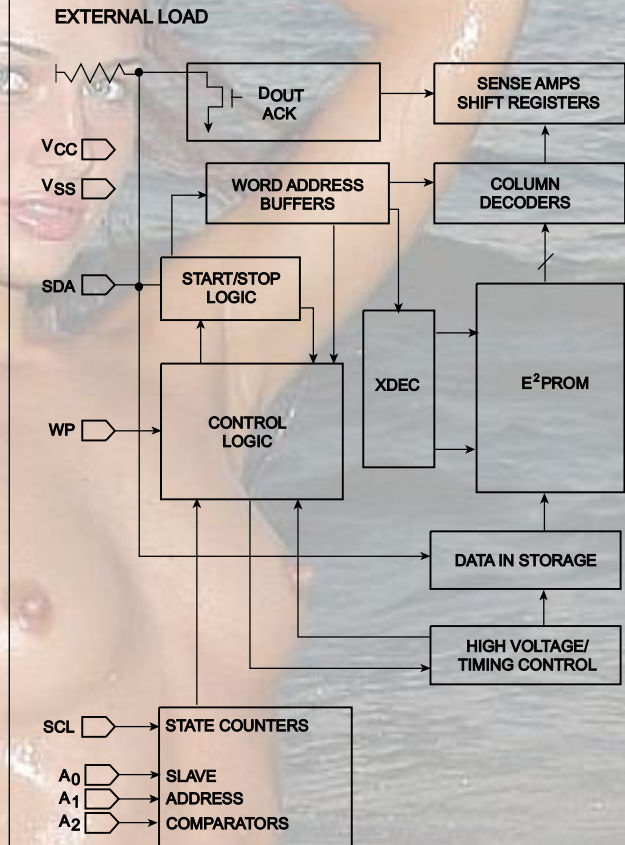

# SCHEMATIC DIAGRAM

## 1. SCALER

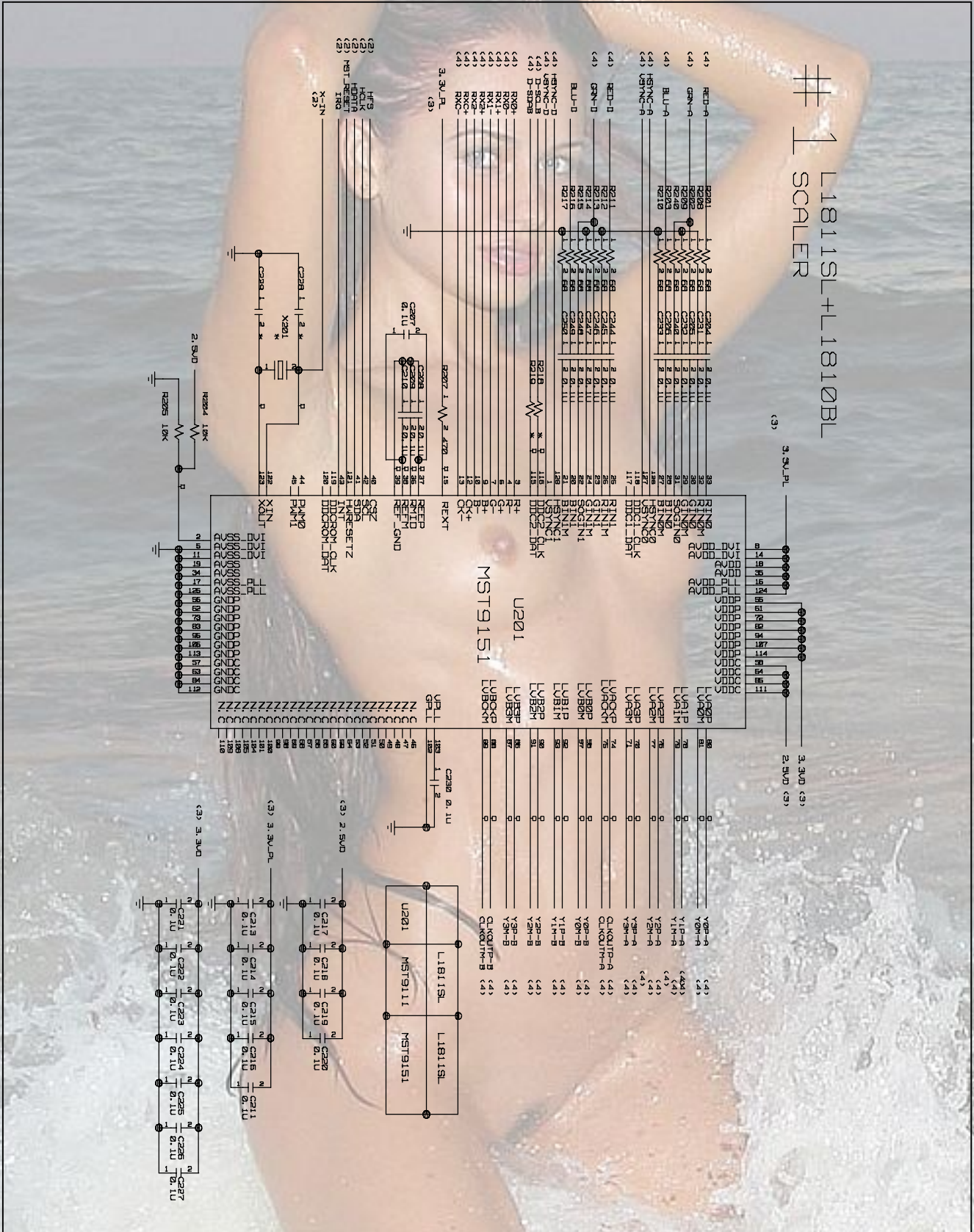



### 3. POWER

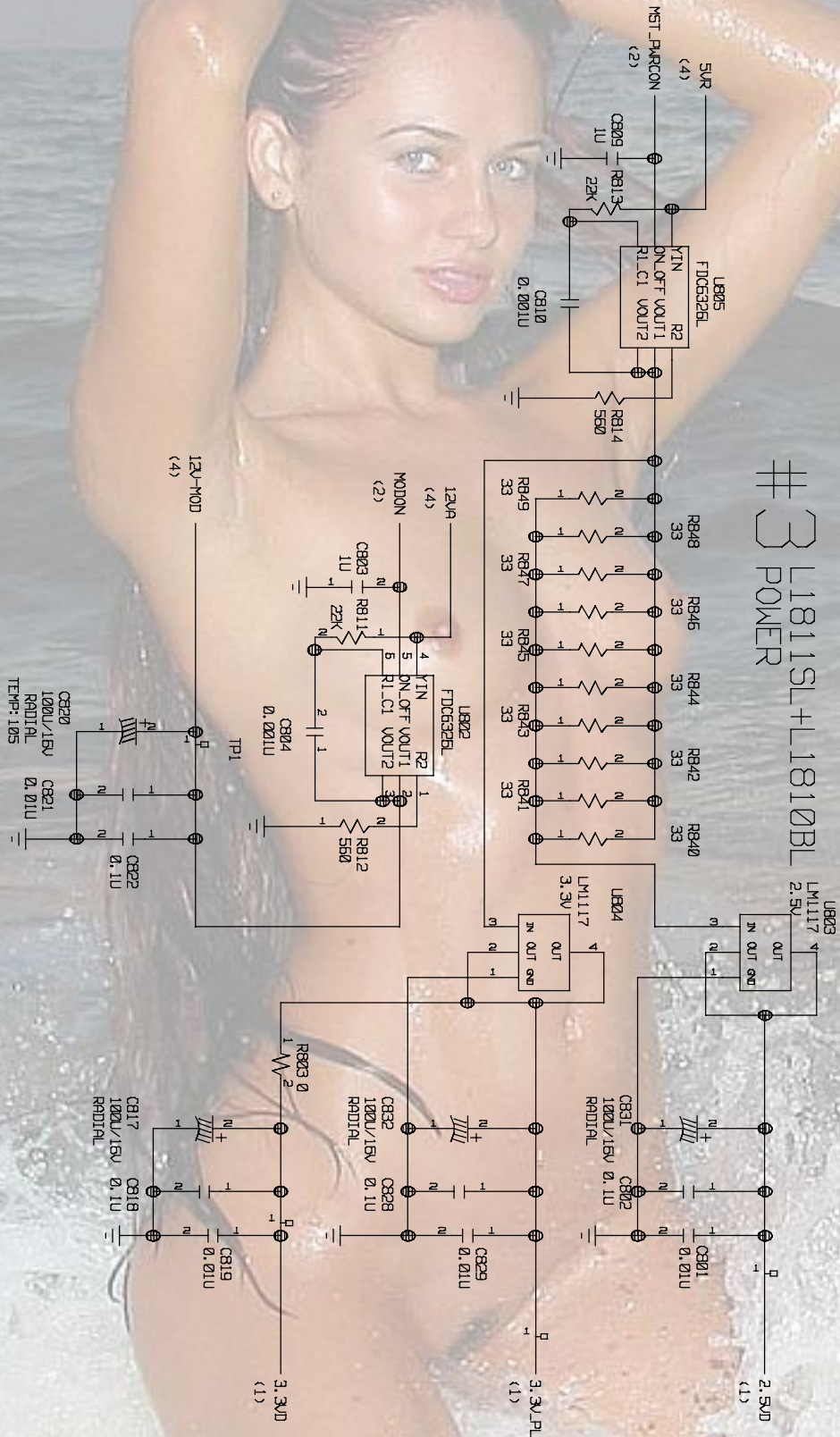

# 4. CONNECTOR/JACKS

## #4 CONNECTOR & JACKS

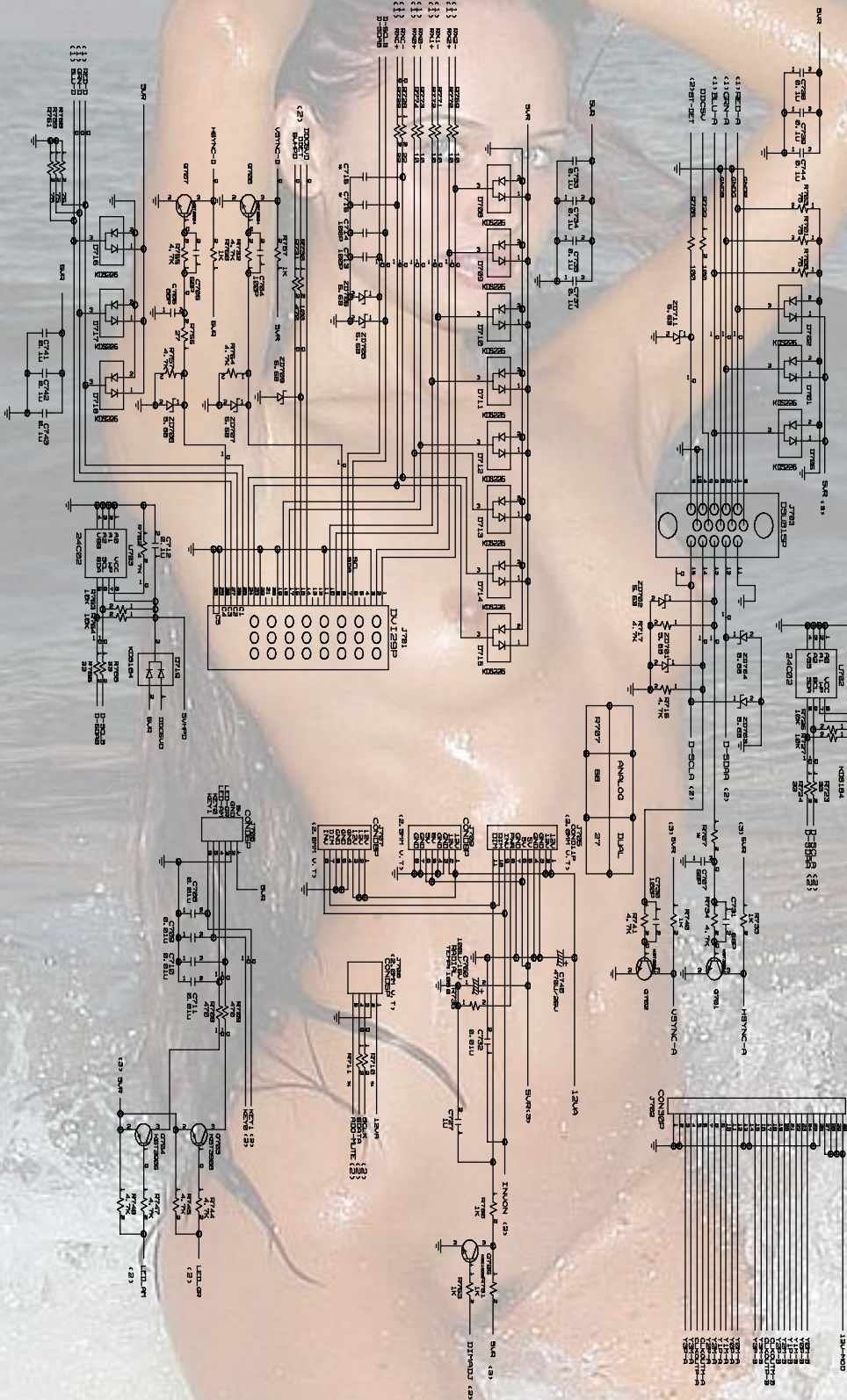

## 5. KEY PART

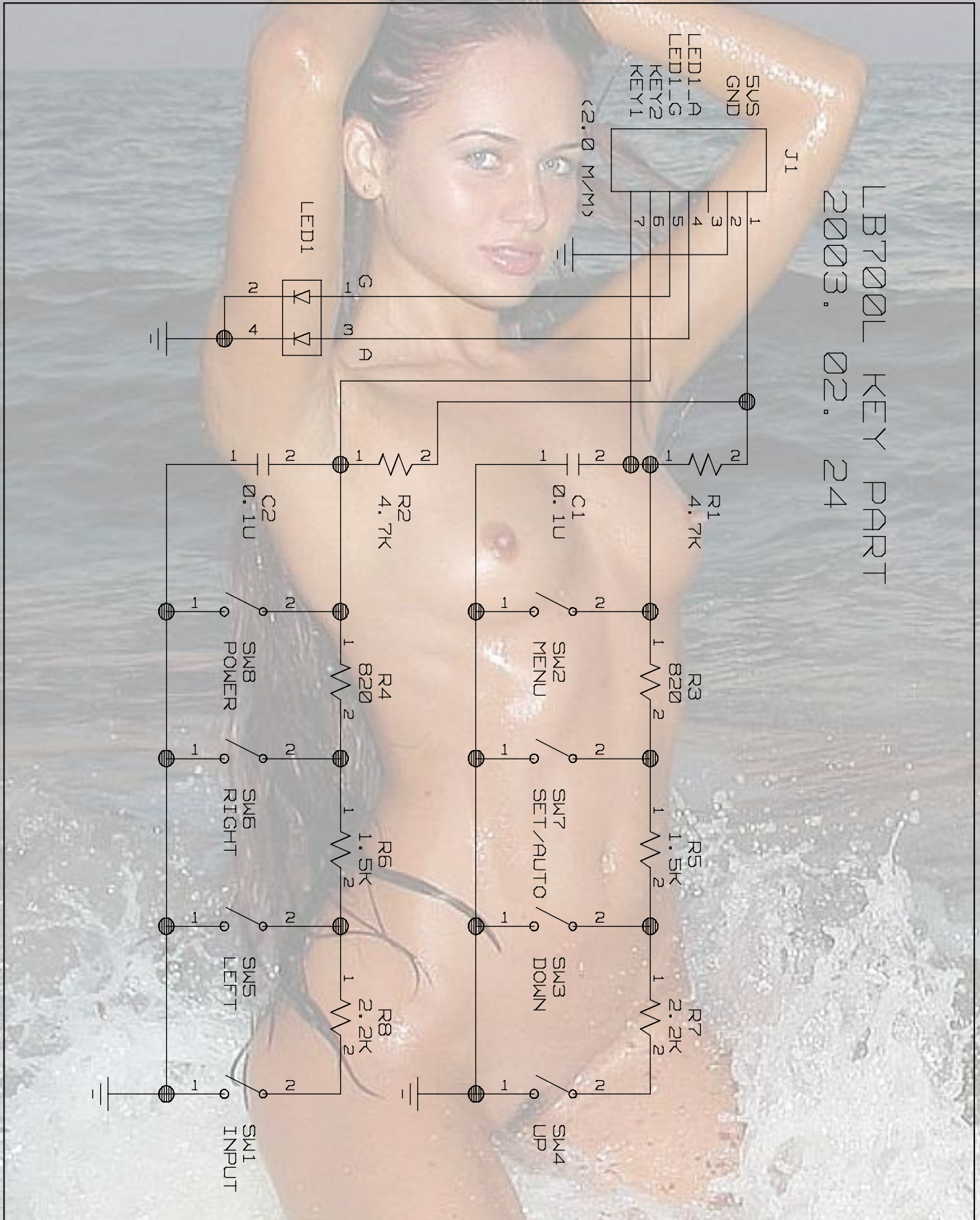



## 6. USB

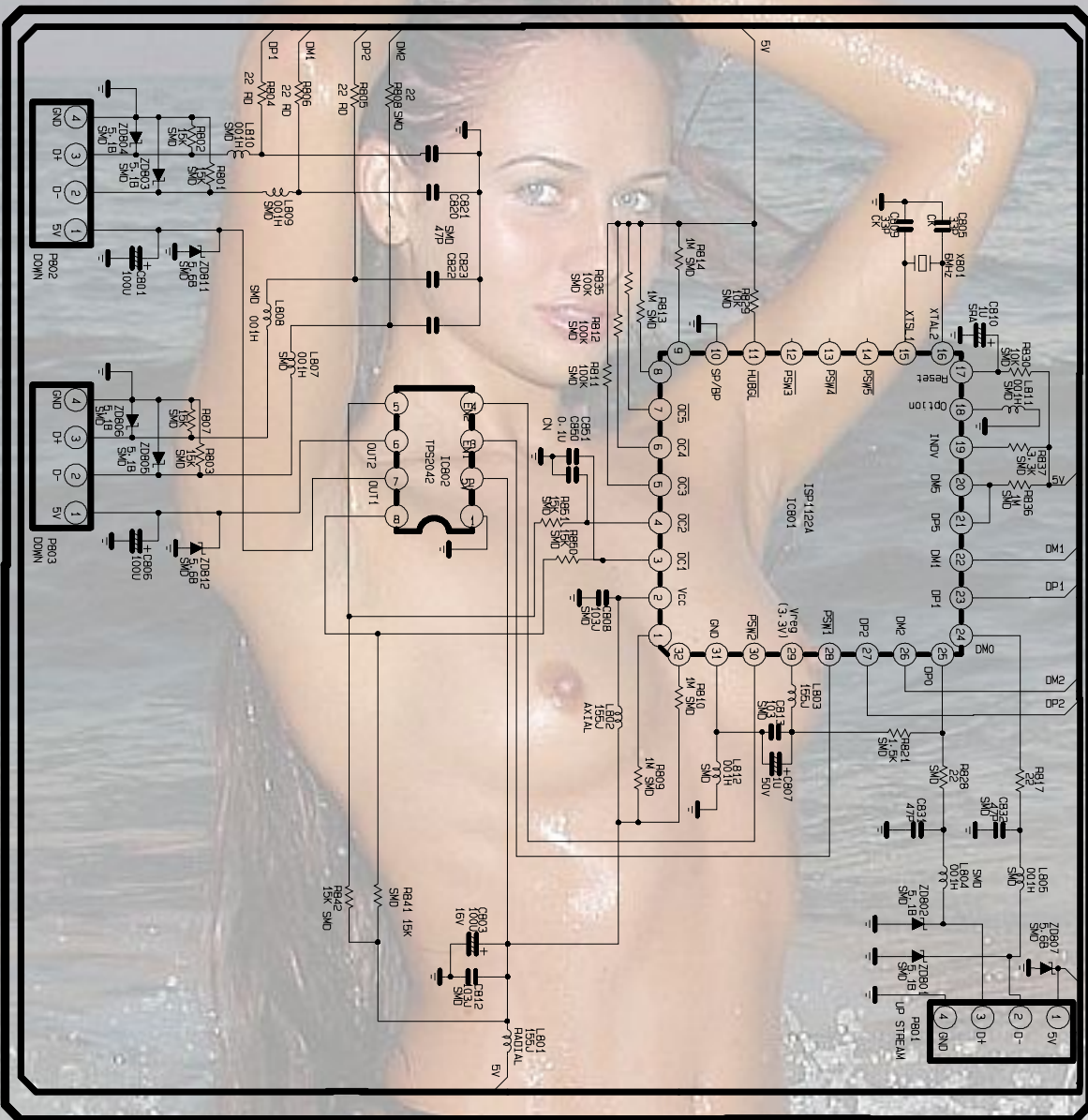

THE  $\Delta$  SYMBOL MARK OF THIS SCHEMATIC DIAGRAM INCORPORATES SPECIAL FEATURES IMPORTANT FOR PROTECTION FROM X-RADIATION, FIRE AND ELECTRICAL SHOCK HAZARDS. WHEN SERVICING IT IS ESSENTIAL THAT ONLY MANUFACTURERS SPECIFIED PARTS BE USED FOR THE CRITICAL COMPONENTS IN THE  $\Delta$  SYMBOL MARK OF THE SCHEMATIC. COMPANY CONFIDENTIAL DO NOT COPY!

DATE	2003.02.03	REV	01
MODEL	L1710L-USB	Sheet	1 / 1 Page

# 7. POWER

## LB886F Internal Power Circuit

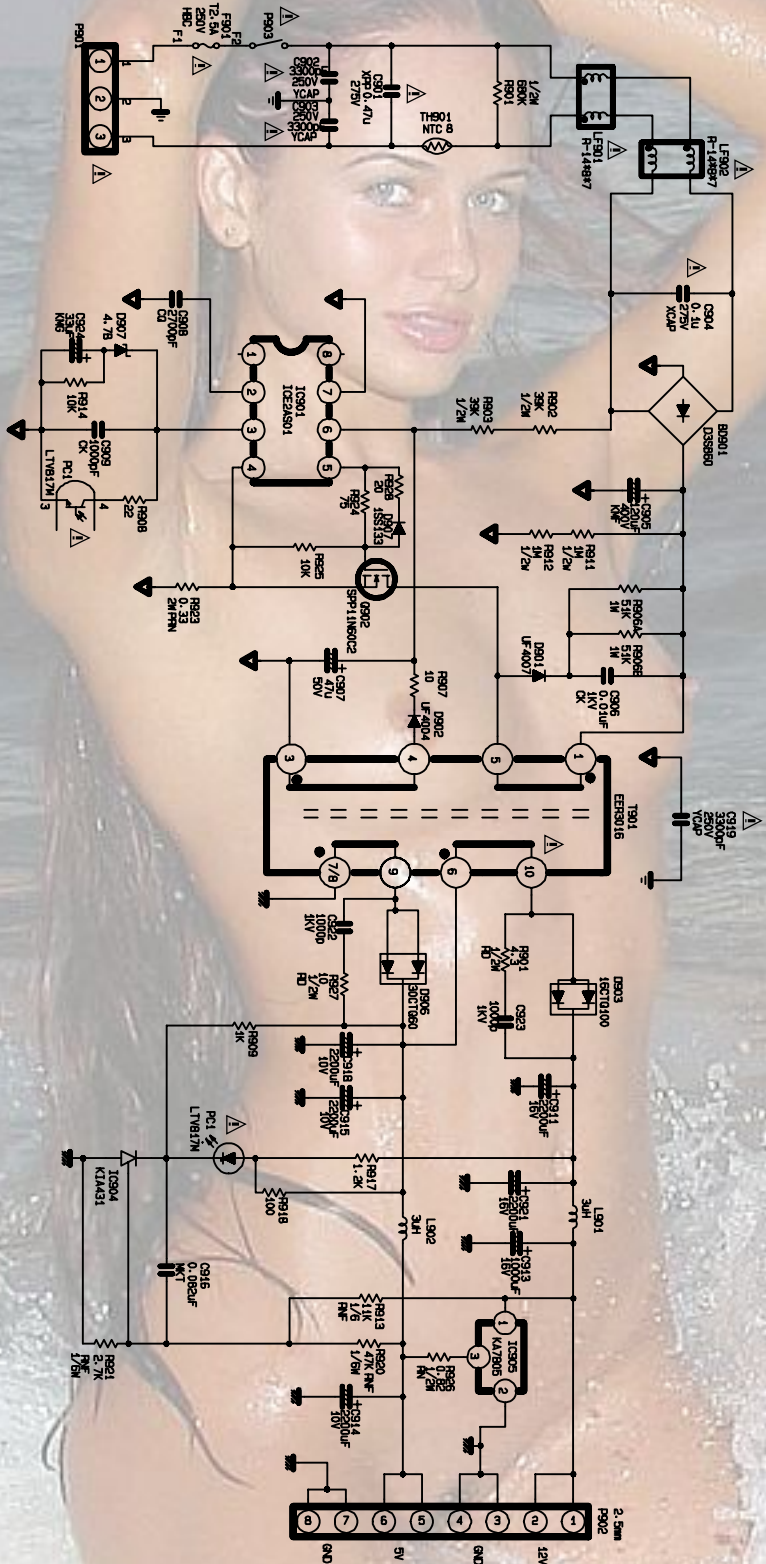

2001.11.21



P/NO : 3828TSL082M

Mar. 2003  
Printed in Korea