



Website: <http://biz.LGservice.com>
E-mail: <http://www.LGservice.com/techsup.html>

COLOR MONITOR SERVICE MANUAL

CHASSIS NO. : CL-42

MODEL: FLATRON L1910P (L1910PL-AF**R)

() **Same model for Service

CAUTION

BEFORE SERVICING THE UNIT,
READ THE **SAFETY PRECAUTIONS** IN THIS MANUAL.



*To apply the **Mstar Chip**.

CONTENTS

SPECIFICATIONS	2	ADJUSTMENT	13
PRECAUTIONS	4	TROUBLESHOOTING GUIDE	14
TIMING CHART	5	PRINTED CIRCUIT BOARD.....	18
OPERATING INSTRUCTIONS	6	EXPLODED VIEW.....	21
WIRING DIAGRAM	9	REPLACEMENT PARTS LIST	23
BLOCK DIAGRAM	10	PIN CONFIGURATION.....	27
DESCRIPTION OF BLOCK DIAGRAM.....	11	SCHEMATIC DIAGRAM.....	28

SPECIFICATIONS

1. LCD CHARACTERISTICS

Type : TFT Color LCD Module
 Size : 19inch(48cm)diagonal
 Pixel Pitch : 0.294(H) x 0.294(V)
 Color Depth : 8-bit, 16,777,216 colors
 Electrical Interface : LVDS
 Surface Treatment : Anti-Glare, Hard Coating(3H)
 Operating Mode : Normally Black
 Backlight Unit : 4-CCFL (Cold Cathode Fluorescent Lamp)

2. OPTICAL CHARACTERISTICS

2-1. Viewing Angle by Contrast Ratio ≥ 10

Left : -80° min., -85°(Typ)
Right : +80° min., +85°(Typ)
Top : +80° min., +85°(Typ)
Bottom : -80° min., -85°(Typ)

2-2. Luminance : 240(min), 300(Typ)

2-3. Contrast Ratio : 400(min), 700(Typ)

3. SIGNAL (Refer to the Timing Chart)

3-1. Sync Signal
 • Type : Separate, Composite, SOG (Sync On Green) Digital

3-2. Video Input Signal

1) Type : R, G, B Analog
 2) Voltage Level : 0~0.7 V
 a) Color 0, 0 : 0 Vp-p
 b) Color 7, 0 : 0.35 Vp-p
 c) Color 15, 0 : 0.7 Vp-p
 3) Input Impedance : 75 Ω

3-3. Operating Frequency

Horizontal(Analog) : 30 ~ 83kHz
 Horizontal(Digital) : 30 ~ 71kHz
 Vertical : 56 ~ 75Hz

4. MAX. RESOLUTION

D-sub Analog : 1280 x 1024@75Hz
 DVI Digital/Analog : 1280 x 1024@60Hz

5. POWER SUPPLY

5-1. Power Adaptor(Built-in Power)
 Input : AC 100-240V~, 50/60Hz , 1.0A
 5-2. Power Consumption

MODE	H/V SYNC	VIDEO	POWER CONSUMPTION	LED COLOR
POWER ON (NORMAL)	ON/ON	ACTIVE	less than 43 W	GREEN
STAND-BY	OFF/ON	OFF	less than 3 W	AMBER
SUSPEND	ON/OFF	OFF	less than 3 W	AMBER
DPM OFF	OFF/OFF	OFF	less than 3 W	AMBER

6. ENVIRONMENT

6-1. Operating Temperature: 10°C~35°C (50°F~95°F)
 (Ambient)
 6-2. Relative Humidity : 10%~80%
 (Non-condensing)
 6-3. MTBF : 50,000 Hours
 Lamp Life : 30,000 Hours(Typ)

7. DIMENSIONS (with TILT/SWIVEL)

Width : 413 mm (16.25")
 Depth : 223 mm (8.78")
 Height : 435mm (17.13")

8. WEIGHT (with TILT/SWIVEL)

Net. Weight : 7.20kg (15.87 lbs)
 Gross Weight : 9.83kg (21.67 lbs)

9. USB

Upstream : 1 port, Downstream : 2 port
 Speed : Full-12Mbps, Low-1.5Mbps

Signal Connector Pin Assignment

• DVI-I Connector (Digital/Analog)

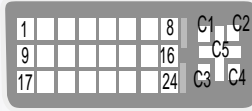

Pin	Signal (DVI-I)
1	T. M. D. S. Data2-
2	T. M. D. S. Data2+
3	T. M. D. S. Data2/4 Shield
4	T. M. D. S. Data4-
5	T. M. D. S. Data4+
6	DDC Clock
7	DDC Data
8	Analog Vertical Sync.
9	T. M. D. S. Data1-
10	T. M. D. S. Data1+
11	T. M. D. S. Data1/3 Shield
12	T. M. D. S. Data3-
13	T. M. D. S. Data3+
14	+5V Power
15	Ground (return for +5V, H. Sync. and V. Sync.)

Pin	Signal (DVI-I)
16	Hot Plug Detect
17	T. M. D. S. Data0-
18	T. M. D. S. Data0+
19	T. M. D. S. Data0/5 Shield
20	T. M. D. S. Data5-
21	T. M. D. S. Data5+
22	T. M. D. S. Clock Shield
23	T. M. D. S. Clock+
24	T. M. D. S. Clock-
C1	Analog Red
C2	Analog Green
C3	Analog Blue
C4	Analog H. Sync.
C5	Analog Ground

T. M. D. S. (Transition Minimized Differential Signaling)

PRECAUTION

WARNING FOR THE SAFETY-RELATED COMPONENT.

- There are some special components used in LCD monitor that are important for safety. **These parts are marked \triangle on the schematic diagram and the replacement parts list.** It is essential that these critical parts should be replaced with the manufacturer's specified parts to prevent electric shock, fire or other hazard.
- Do not modify original design without obtaining written permission from manufacturer or you will void the original parts and labor guarantee.

\triangle WARNING

BE CAREFUL ELECTRIC SHOCK !

- If you want to replace with the new backlight (CCFL) or inverter circuit, must disconnect the AC adapter because high voltage appears at inverter circuit about 650Vrms.
- Handle with care wires or connectors of the inverter circuit. If the wires are pressed cause short and may burn or take fire.

TAKE CARE DURING HANDLING THE LCD MODULE WITH BACKLIGHT UNIT.

- Must mount the module using mounting holes arranged in four corners.
- Do not press on the panel, edge of the frame strongly or electric shock as this will result in damage to the screen.
- Do not scratch or press on the panel with any sharp objects, such as pencil or pen as this may result in damage to the panel.
- Protect the module from the ESD as it may damage the electronic circuit (C-MOS).
- Make certain that treatment person's body are grounded through wrist band.
- Do not leave the module in high temperature and in areas of high humidity for a long time.
- The module not be exposed to the direct sunlight.
- Avoid contact with water as it may a short circuit within the module.
- If the surface of panel become dirty, please wipe it off with a softmaterial. (Cleaning with a dirty or rough cloth may damage the panel.)

\triangle CAUTION

Please use only a plastic screwdriver to protect yourself from shock hazard during service operation.

TIMING CHART

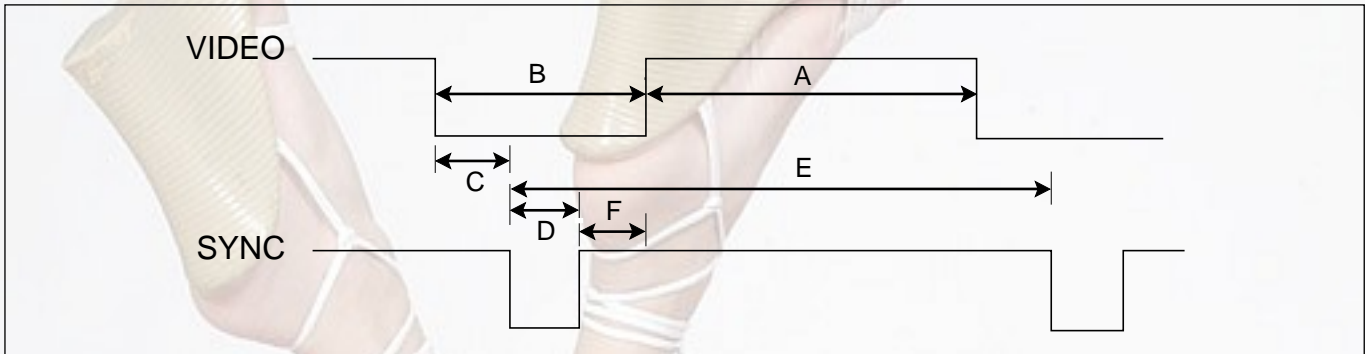

<< Dot Clock (MHz), Horizontal Frequency (kHz), Vertical Frequency (Hz), Horizontal etc... (μs), Vertical etc... (ms) >>

Mode	H/V Sort	Sync Polarity	Dot Clock	Frequency	Total Period (E)	Video Active Time (A)	Front Porch (C)	Sync Duration (D)	Back Porch (F)	Resolution
1	H	+	25.175	31.469	800	640	16	96	48	640x350 70Hz
	V	-		70.8	449	350	37	2	60	
2	H	-	28.321	31.468	900	720	18	108	54	720x400 70Hz
	V	+		70.09	449	400	12	2	35	
3	H	-	25.175	31.469	800	640	16	96	48	640x480 60Hz
	V	-		59.94	525	480	10	2	33	
4	H	-	31.5	37.5	840	640	16	64	120	640x480 75Hz
	V	-		75	500	480	1	3	16	
5	H	+	40.0	37.879	1056	800	40	128	88	800x600 60Hz
	V	+		60.317	628	600	1	4	23	
6	H	+	49.5	46.875	1056	800	16	80	160	800x600 75Hz
	V	+		75.0	625	600	1	3	21	
7	H	+/-	57.283	49.725	1152	832	32	64	224	832x624 75Hz
	V	+/-		74.55	667	624	1	3	39	
8	H	-	65.0	48.363	1344	1024	24	136	160	1024x768 60Hz
	V	-		60.0	806	768	3	6	29	
9	H	-	78.75	60.123	1312	1024	16	96	176	1024x768 75Hz
	V	-		75.029	800	768	1	3	28	
10	H	+/-	100.0	68.681	1456	1152	32	128	144	1152x900 75Hz
	V	+/-		75.062	915	870	3	3	39	
11	H	+/-	92.978	61.805	1504	1152	18	134	200	1152x900 65Hz
	V	+/-		65.96	937	900	2	4	31	
12	H	+	108.0	63.981	1688	1280	48	112	248	1280x1024 60Hz
	V	+		60.02	1066	1024	1	3	38	
13	H	+	135.0	79.976	1688	1280	16	144	248	1280x1024 75Hz
	V	+		75.035	1066	1024	1	3	38	

OPERATING INSTRUCTIONS

FRONT VIEW

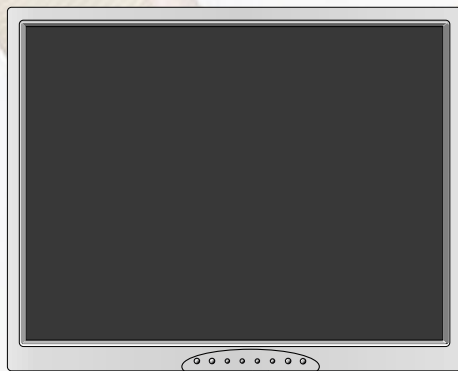

Front Control Panel

REAR VIEW

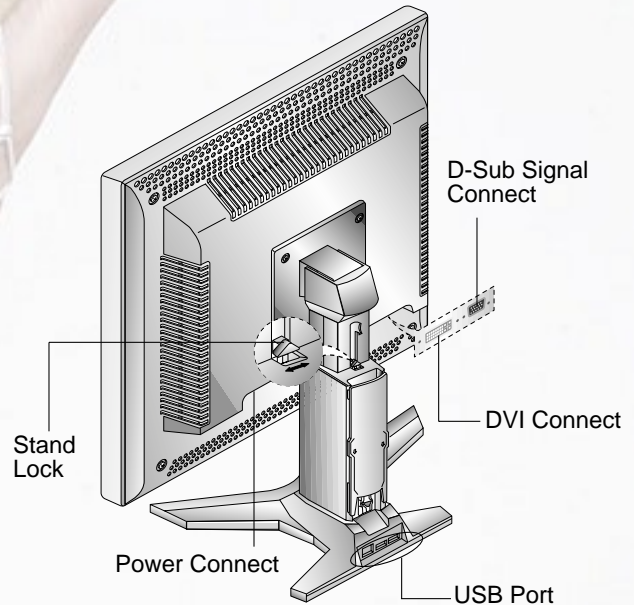

Stand Lock

D-Sub Signal Connect

DVI Connect

Power Connect

USB Port

Front Control Panel

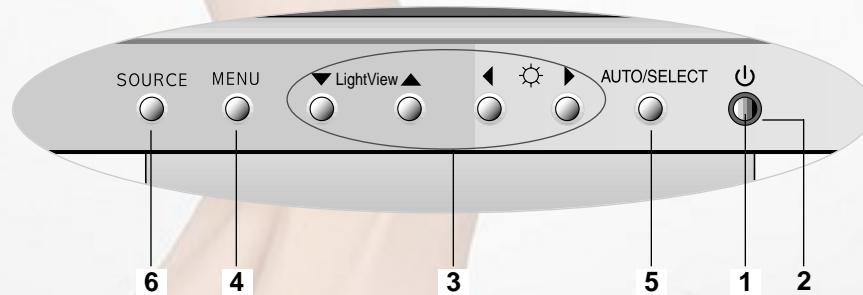

1. Power ON/OFF Button

Use this button to turn the monitor on or off.

2. Power Indicator

This indicator lights up green when the monitor operates normally. If the display is in DPM(Energy Saving)mode, this indicator color change to amber.

3. Button

Use these buttons to choose or adjust items in the On Screen Display.

▼ LightView ▲

This function optimizes the brightness, contrast or color value to the surrounding conditions and settings and enables you to enjoy the most suitable picture by adjusting the surroundings (DAY/NIGHT/USER MODE).

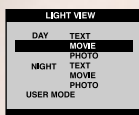

- TEXT: For viewing letters
- MOVIE: For viewing movies
- PHOTO: For viewing pictures or the photographs
- USER MODE: This function memorizes the manual adjustment -Brightness, Contrast and Color value on the On Screen Display.

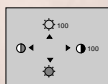

Bring up Contrast and Brightness adjustment.

: ◀ ⚙ ▶ → ▼ ▲ ◀ ▶ → MENU

4. MENU Button

Use this button to enter or exit the On Screen Display.

5. AUTO/SELECT Button

Use this button to enter a selection in the On Screen Display.

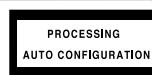

When adjusting your display settings, always press the **AUTO/SELECT** button before entering the On Screen Display(OSD). This will automatically adjust your display image to the ideal settings for the current screen resolution size(display mode). The best display mode is **1280x1024/60Hz**.

6. SOURCE Button

Use this button to make Dsub or DVI connector active.

This feature is used when two computers are connected to the monitor. The default setting is Dsub.



CONTROLS LOCKED/UNLOCKED

: MENU and ►



This function allows you to secure the current control settings, so that they cannot be inadvertently changed. Press and hold the MENU button and ► button for 3 seconds: the message “CONTROLS LOCKED” appears.

You can unlock the OSD controls at any time by pushing the MENU button and ► button for 3 seconds: the message “CONTROLS UNLOCKED” will appear.

- Before setting up the monitor, ensure that the power to the monitor, the computer system, and other attached devices is turned off.

Positioning your display

- Adjust the position of the panel in various ways for maximum comfort.

- Tilt Range : -5° ~30°

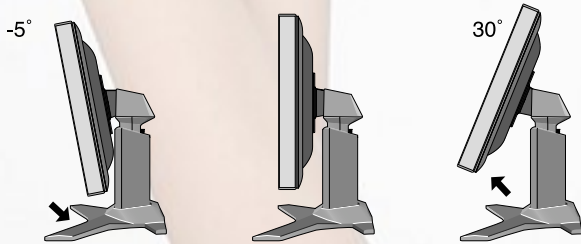

- Height Range : maximum 3.15 inch (80.0mm)

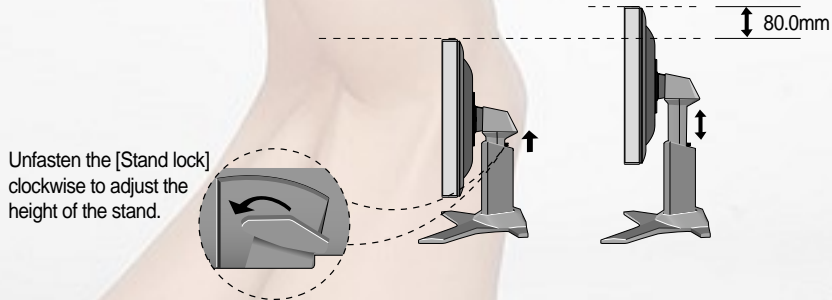

- Landscape & Portrait : You can rotate the panel 90° clockwise.
(* For detailed information, please refer to the Pivot Software CD provided.)

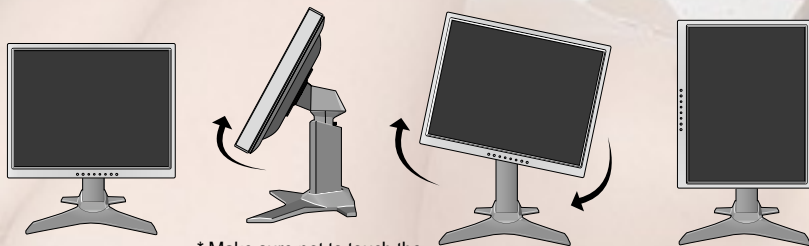

* Make sure not to touch the floor when the head rotates to use the Pivot function.

Ergonomic

It is recommended that in order to maintain an ergonomic and comfortable viewing position, the forward tilt angle of the monitor should not exceed 5 degrees.

Making use of USB (Universal Serial Bus)*

USB (Universal Serial Bus) is an innovation in connecting your different desktop peripherals conveniently to your computer. By using the USB, you will be able to connect your mouse, keyboard, and other to your monitor instead of having to connect them to your computer. This will give you greater flexibility in setting up your system. USB allows you to connect chain up to 120 devices on a single USB port, and you can “hot” plug (attach them while the computer is running) or unplug them while maintaining Plug and Play auto detection and configuration. This monitor has an integrated BUS-powered USB hub, allowing up to 2 other USB devices to be attached it.

USB connection

1. Connect the upstream port of the Display to the downstream port of the USB compliant PC or another hub using the USB cable. (Computer must have a USB port)
2. Connect the USB compliant peripherals to the downstream ports of the monitor.

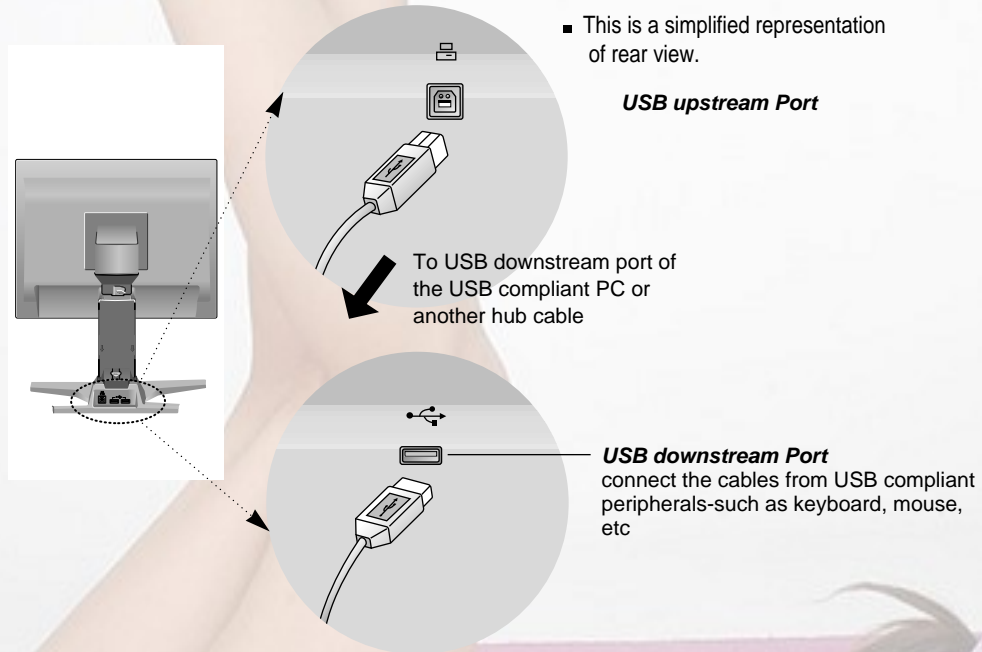

NOTE

- To activate the USB hub function, the monitor must be connected to a USB compliant PC(OS) or another hub with the USB cable(enclosed).
- When connecting the USB cable, check that the shape of the connector at the cable side matches the shape at the connecting side.
- Even if the monitor is in a power saving mode, USB compliant devices will function when they are connected the USB ports(both the upstream and downstream) of the monitor.

WIRING DIAGRAM

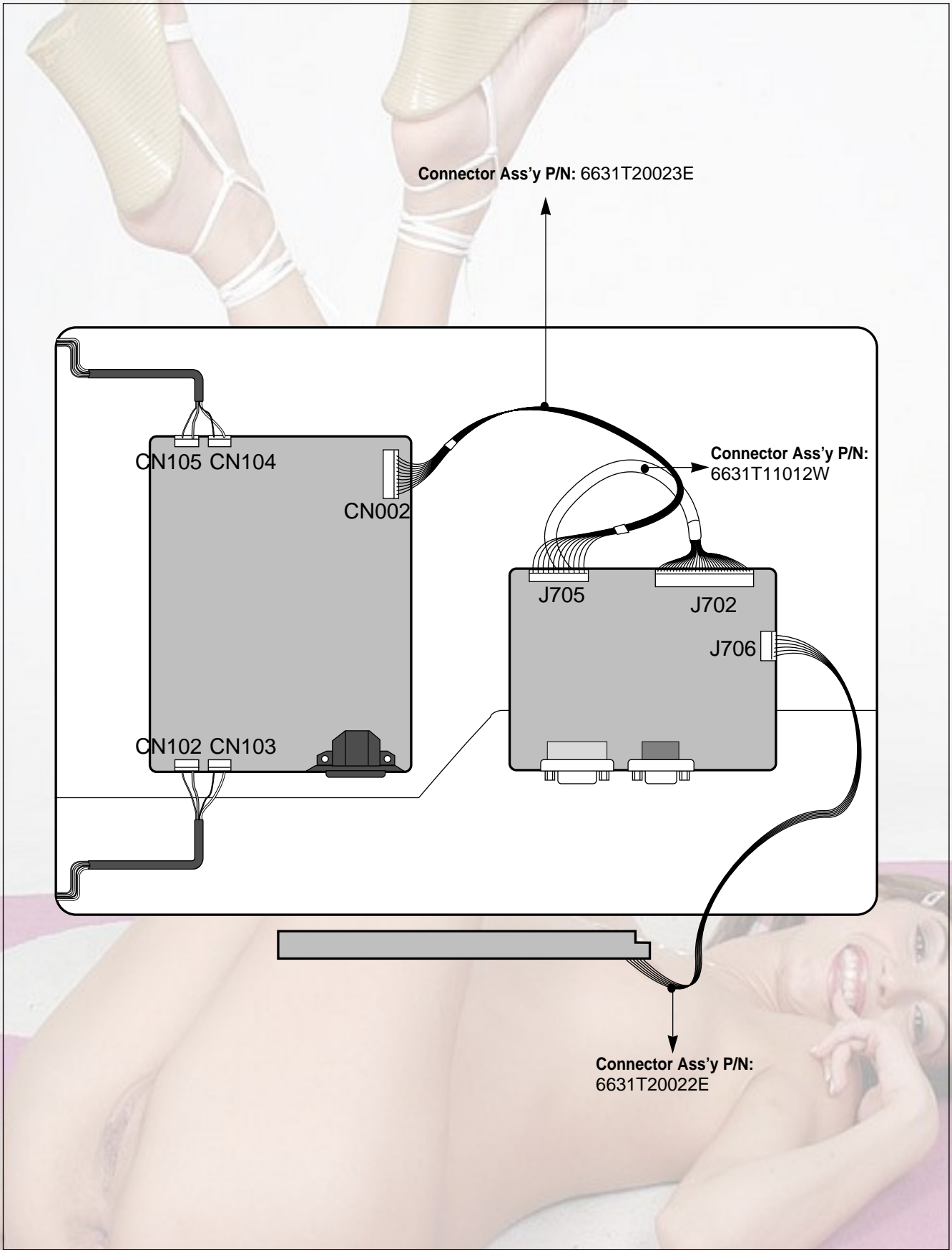

BLOCK DIAGRAM

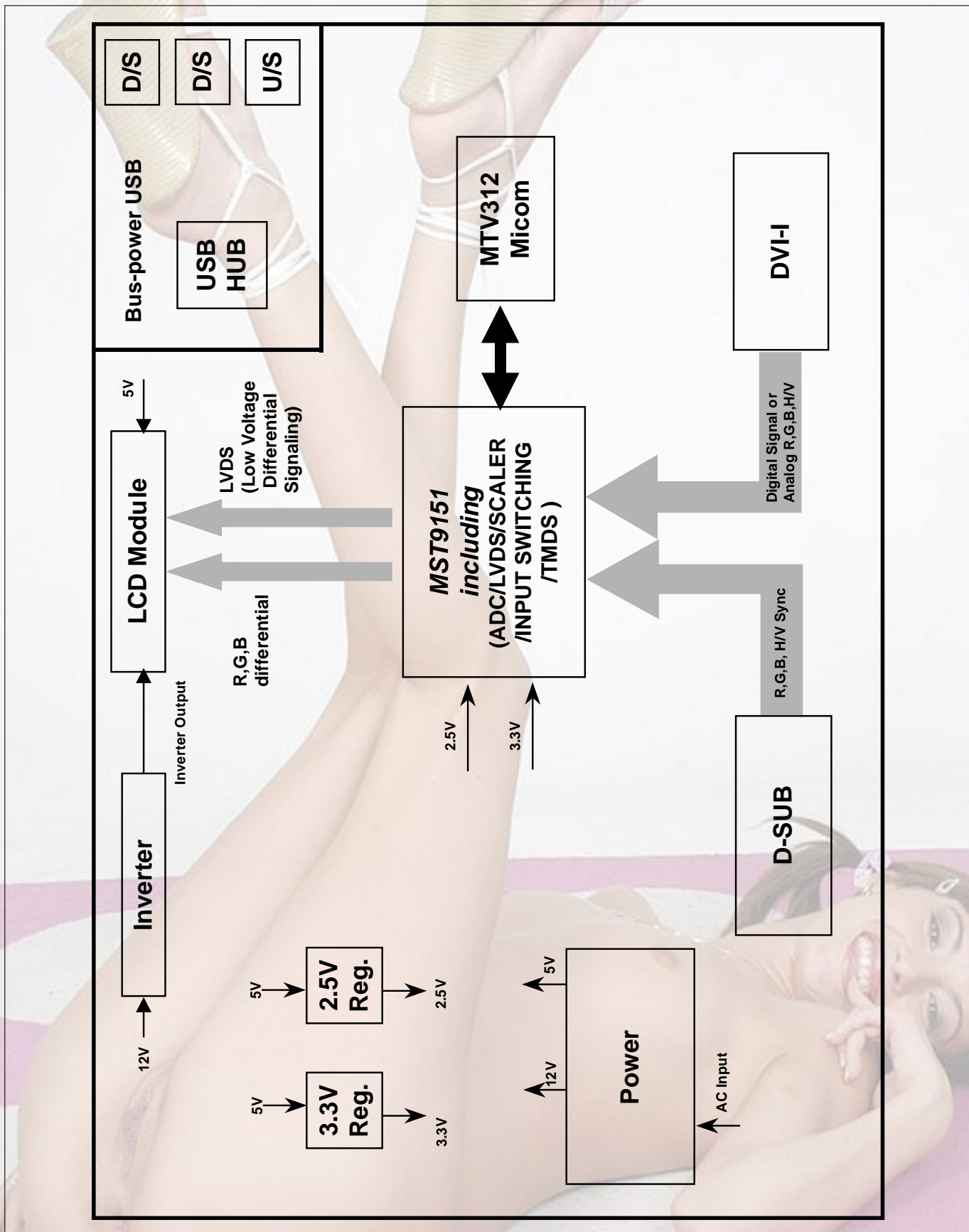

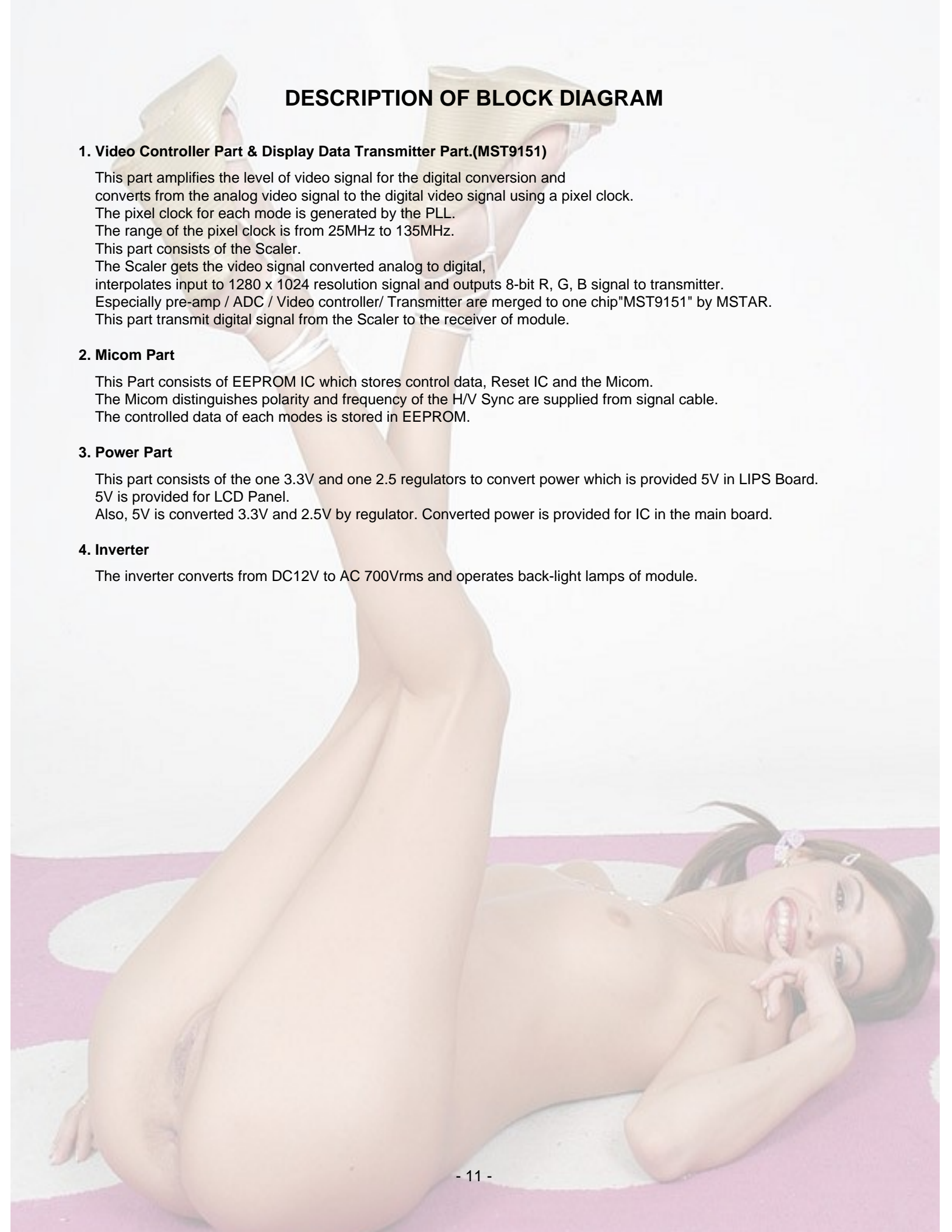

DESCRIPTION OF BLOCK DIAGRAM

1. Video Controller Part & Display Data Transmitter Part.(MST9151)

This part amplifies the level of video signal for the digital conversion and converts from the analog video signal to the digital video signal using a pixel clock.

The pixel clock for each mode is generated by the PLL.

The range of the pixel clock is from 25MHz to 135MHz.

This part consists of the Scaler.

The Scaler gets the video signal converted analog to digital, interpolates input to 1280 x 1024 resolution signal and outputs 8-bit R, G, B signal to transmitter.

Especially pre-amp / ADC / Video controller/ Transmitter are merged to one chip "MST9151" by MSTAR.

This part transmit digital signal from the Scaler to the receiver of module.

2. Micom Part

This Part consists of EEPROM IC which stores control data, Reset IC and the Micom.

The Micom distinguishes polarity and frequency of the H/V Sync are supplied from signal cable.

The controlled data of each modes is stored in EEPROM.

3. Power Part

This part consists of the one 3.3V and one 2.5 regulators to convert power which is provided 5V in LIPS Board. 5V is provided for LCD Panel.

Also, 5V is converted 3.3V and 2.5V by regulator. Converted power is provided for IC in the main board.

4. Inverter

The inverter converts from DC12V to AC 700Vrms and operates back-light lamps of module.

LIPS Board Block Diagram

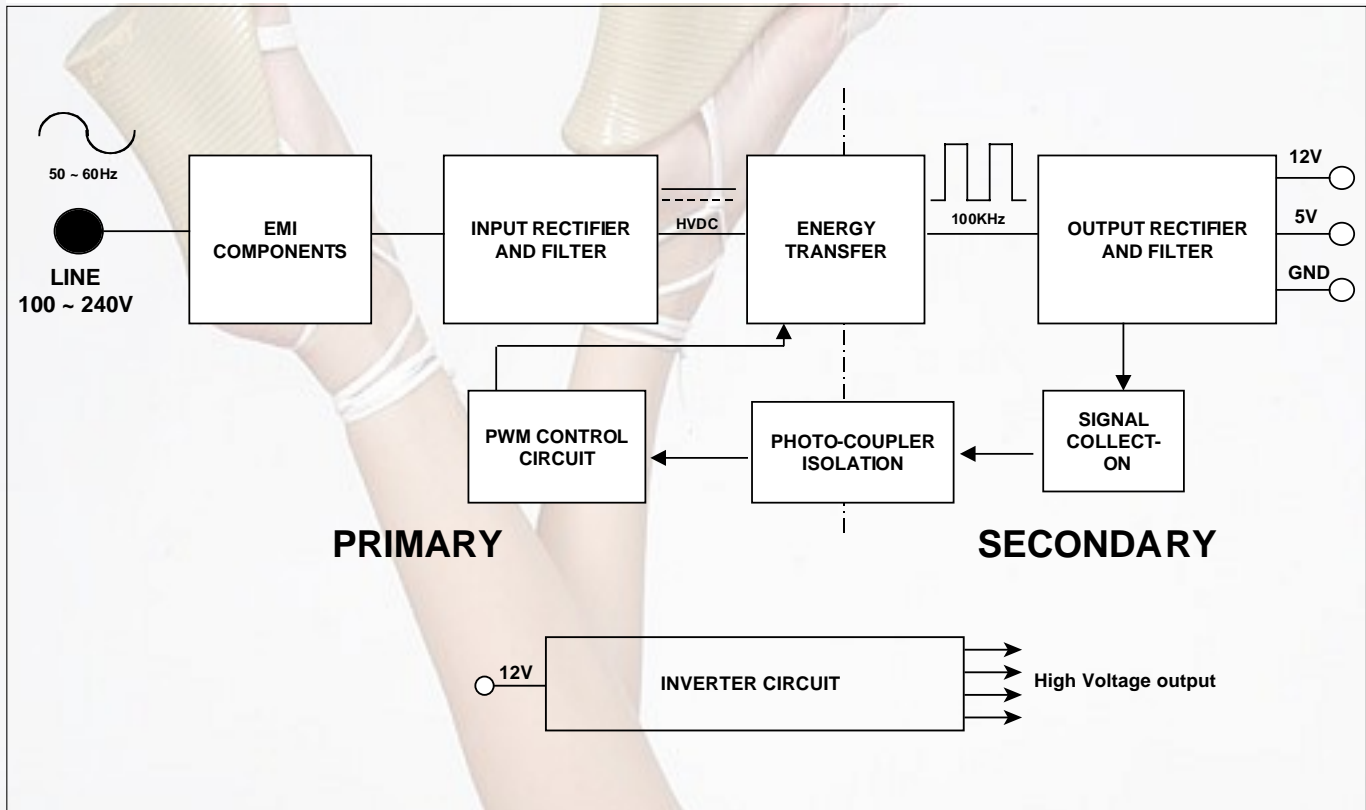

Operation description_LIPS

1. EMI components.

This part contains of EMI components to comply with global marketing EMI standards like FCC, VCCI CISPR, the circuit included a line-filter, across line capacitor and of course the primary protection fuse.

2. Input rectifier and filter.

This part function is for transfer the input AC voltage to a DC voltage through a bridge rectifier and a bulk capacitor.

3. Energy Transfer.

This part function is transfer the primary energy to secondary through a power transformer.

4. Output rectifier and filter.

This part function is to make a pulse width modulation control and to provide the driver signal to power switch, to adjust the duty cycle during different AC input and output loading condition to achive the dc output stablize, and also the over power protection is also monitor by this part.

5. Photo-Coupler isolation.

This part function is to feed back the dc output changing status through a photo transistor to primary controller to achieve the stabilized dc output voltage.

6. Signal collection.

This part function is to collect the any change from the dc output and feed back to the primary through photo transistor.

7. Inverter

The inverter converts from DC12V to AC 700V and operate back-light lamp of module.

ADJUSTMENT

All adjustment are thoroughly checked and corrected when the monitor leaves the factory, but sometimes several minor adjustment may be required.

Adjustment should be following procedure and after warming up for a minimum of 10 minutes.

- Alignment appliances and tools.
 - IBM compatible PC
 - Programmable Signal Generator. (eg. VG-819 made by Astrodesign Co.)
 - E(E)PROM with each mode data saved.

1. Adjustment process for LCD MONITOR

- 1) Display half window pattern(or mixed white and black pattern)at Mode 8 (1024x768@60Hz).
- 2) Press the POWER and MENU key at the same time to light monitor, then go to adjustment mode.
- 3) Press the MENU s/w, next press UP button, you will see adjustment OSD menu.
- 4) Press the AUTO/SELECT to select the adjustment item first(use the same button to exit)next do the operation to the relative item.Ex) 17HYDIS is used at 17AU, press right button to select. Press the AUTO/SELECT then selected proper Module.
- 5) Press down button to move the place of ADC CAL. Press the AUTO/SELECT to select, right button is pressed for adjustment.
- 6) When adjustment is finished, press the POWER key twice to light monitor again. The adjustment ends.

2. Adjustment for EDID

- 1) Use this procedure only when there is some probelm on EDID data.
- 2) Connect the D-sub cable.
- 3) Select EDID → Write EDID[A0] command and Enter.

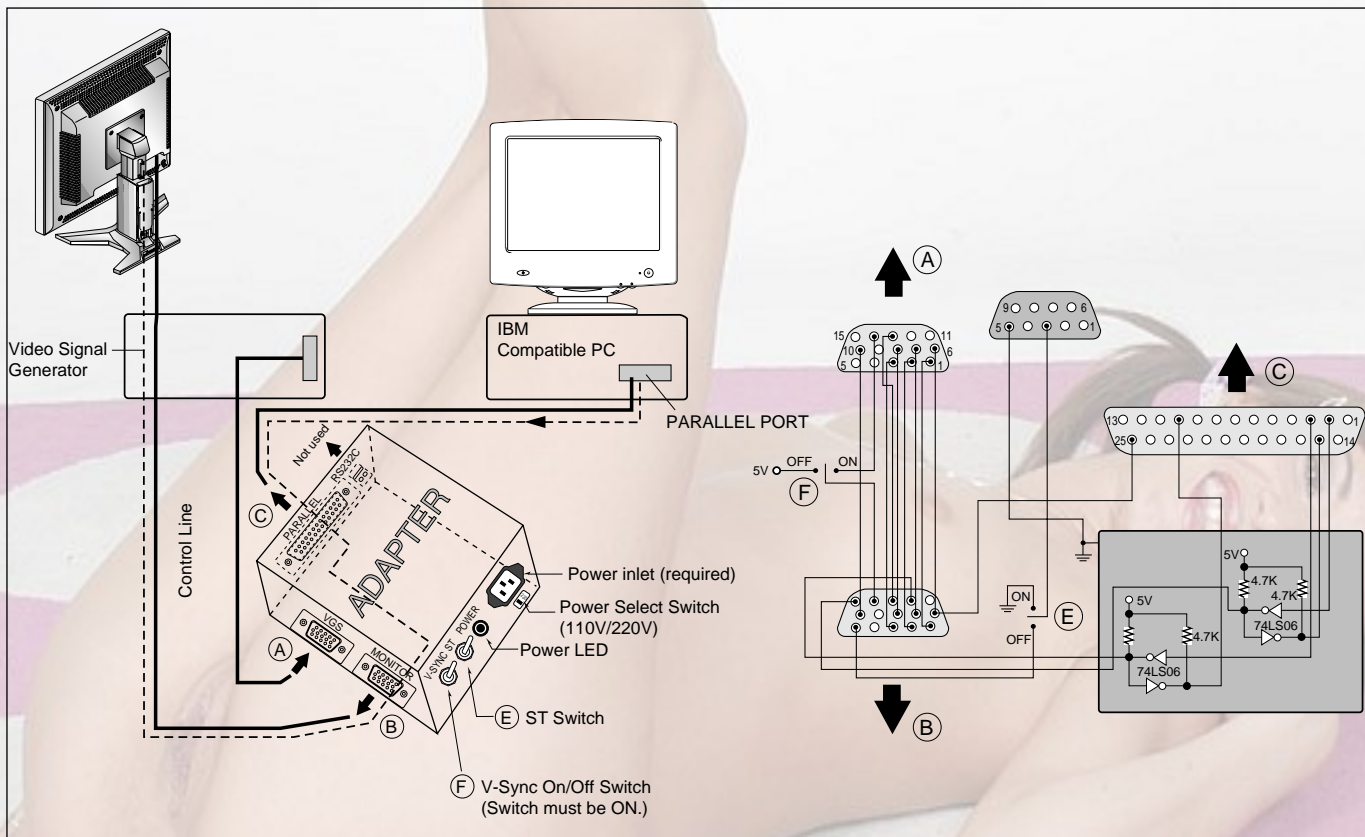
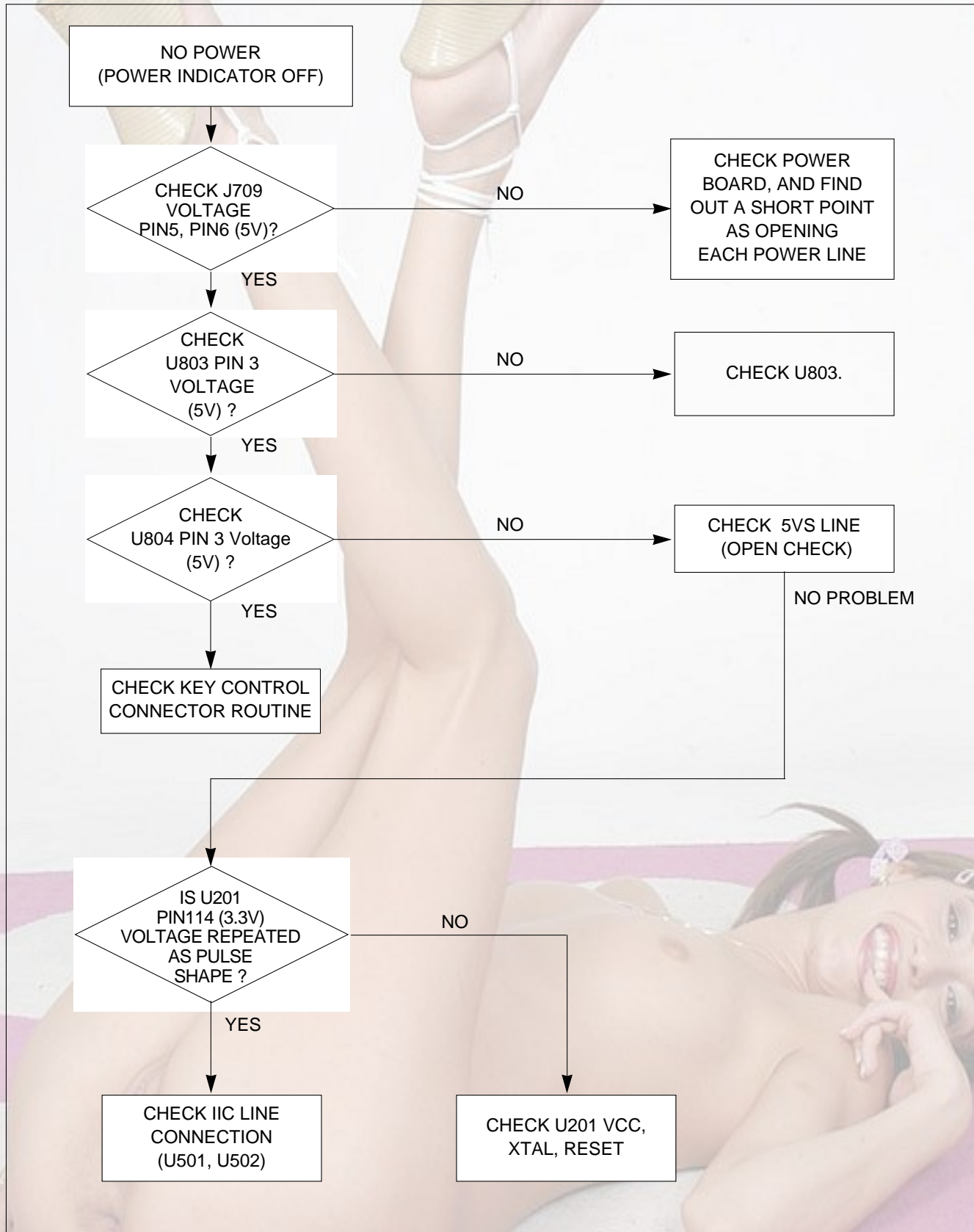

Figure 1. Cable Connection

TROUBLESHOOTING GUIDE

1. NO POWER



2. NO RASTER (OSD IS NOT DISPLAYED) – LIPS

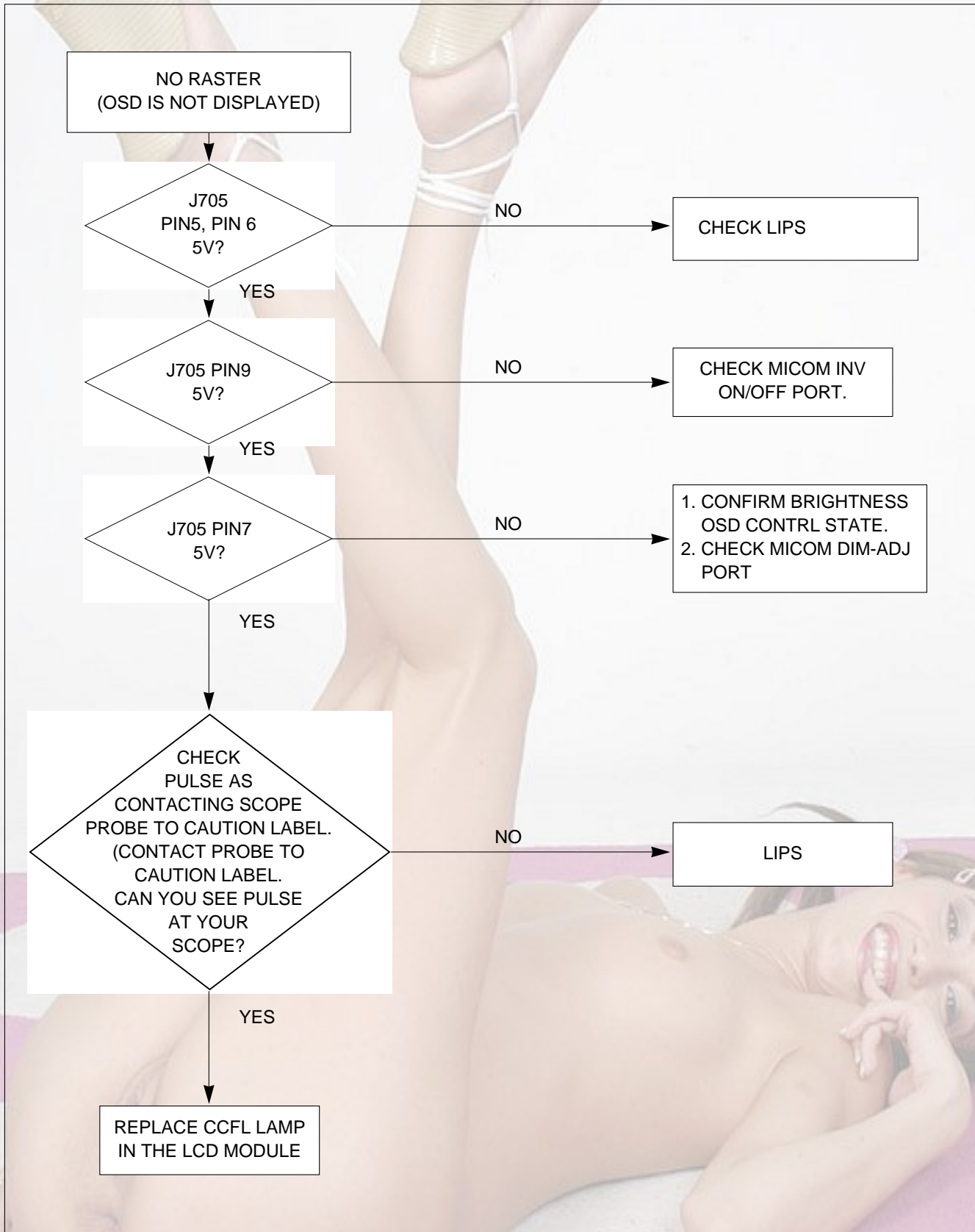

3. NO RASTER (OSD IS NOT DISPLAYED) – MST9151

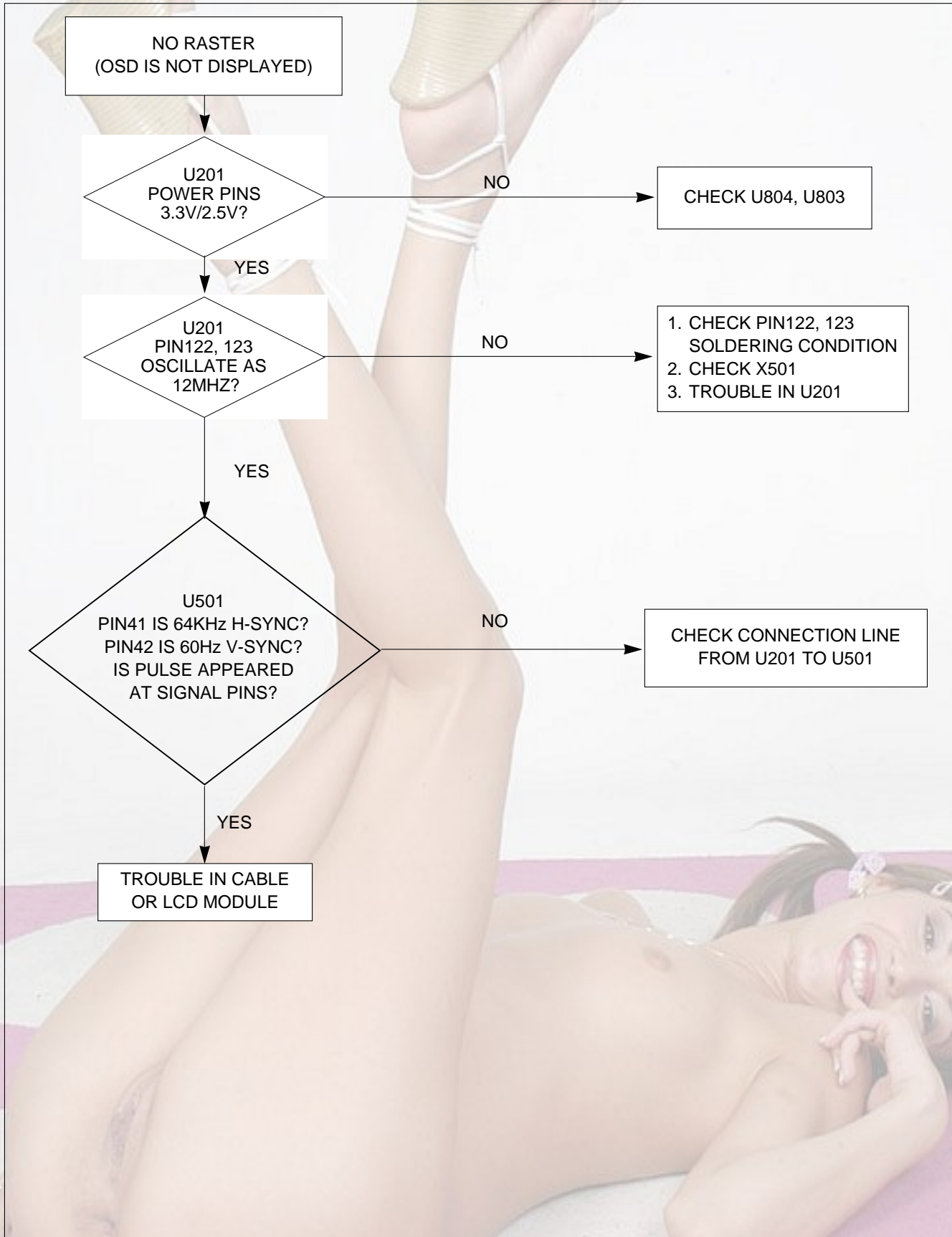

4. TROUBLE IN DPM

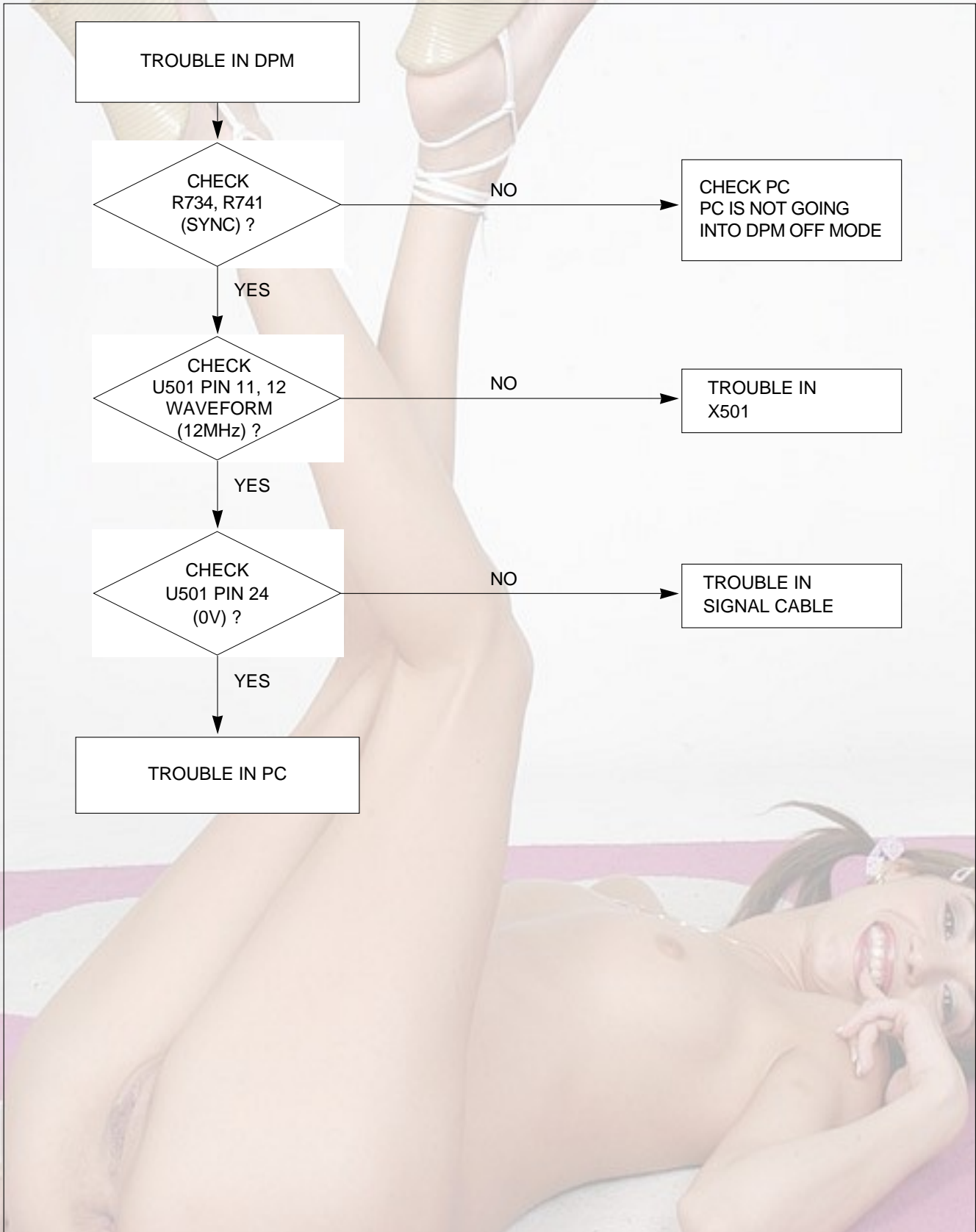

PRINTED CIRCUIT BOARD

1. MAIN BOARD (Component Side)

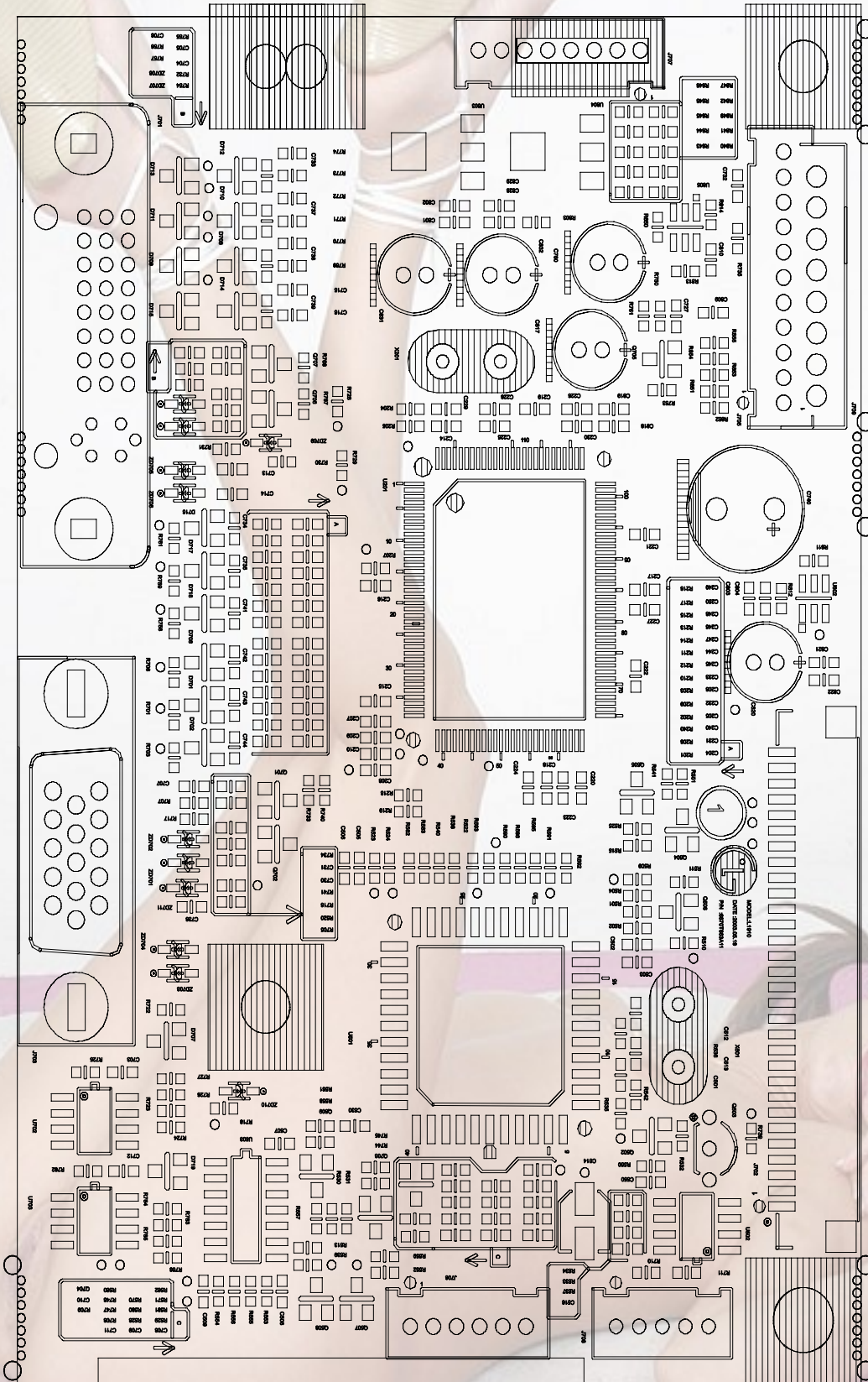

2. POWER BOARD (Component Side)

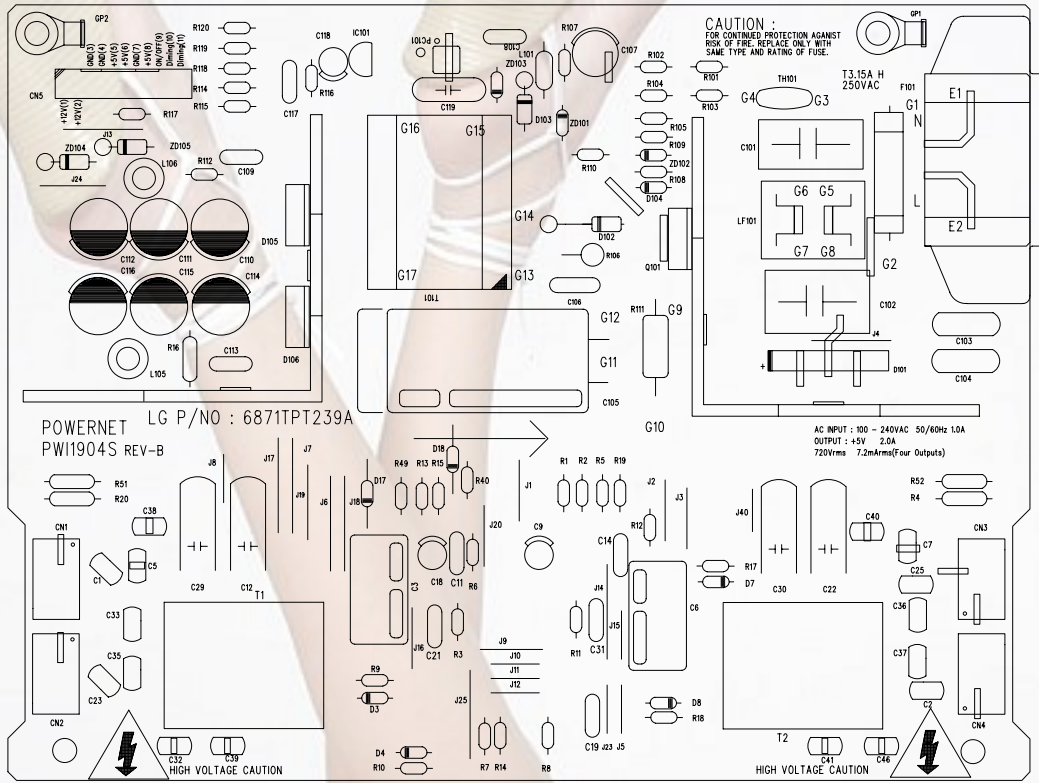

3. POWER BOARD (Solder Side)

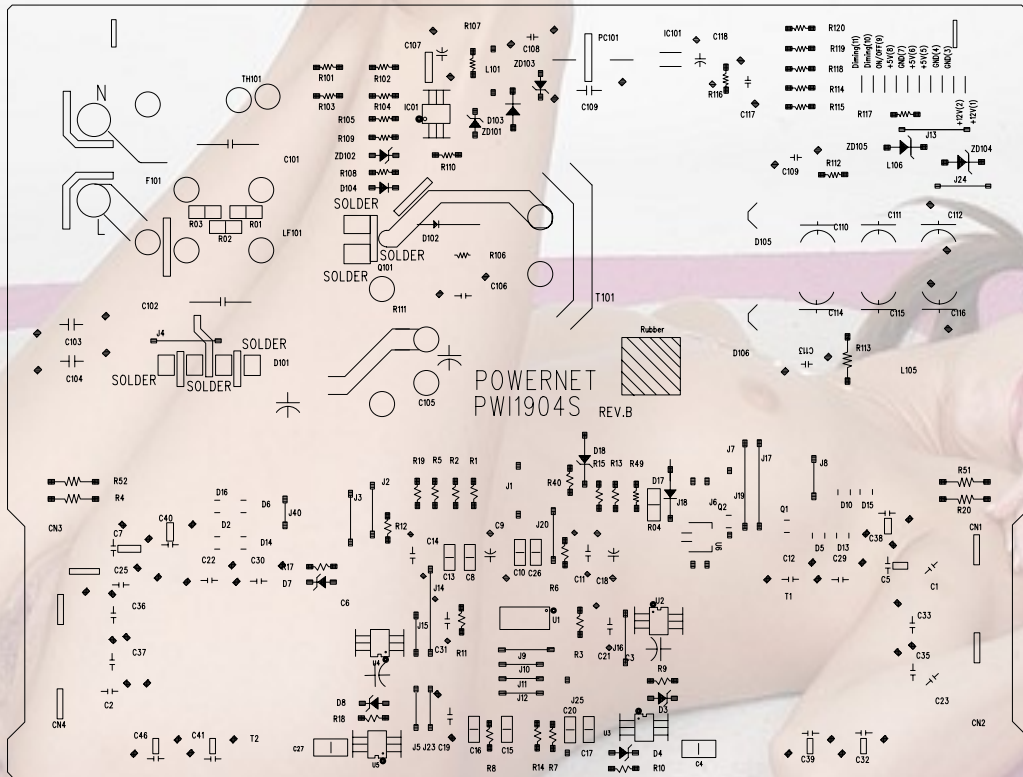

4.USB BOARD

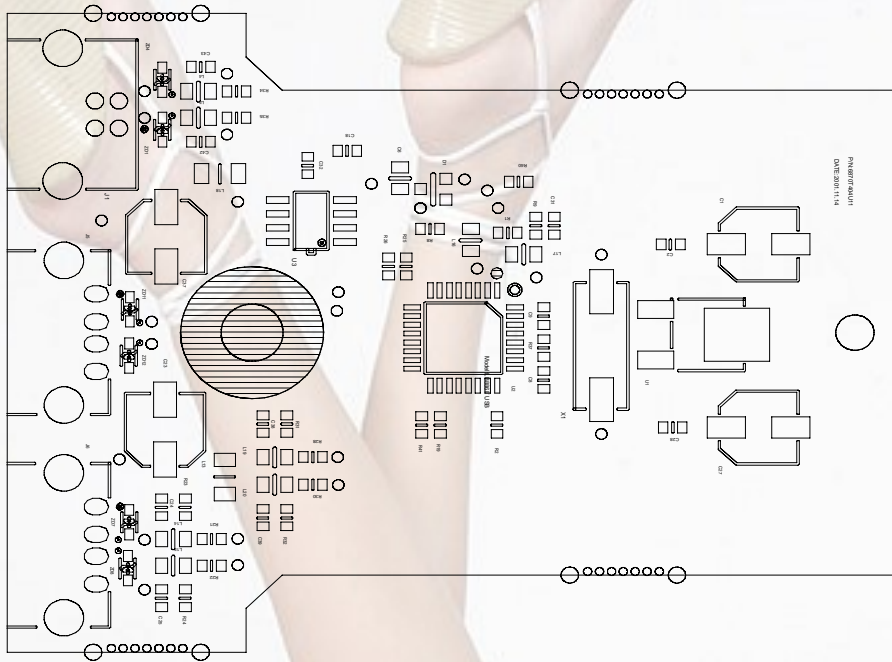

5. CONTROL BOARD

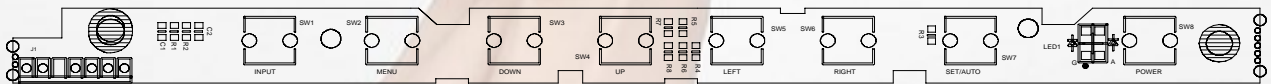

EXPLODED VIEW

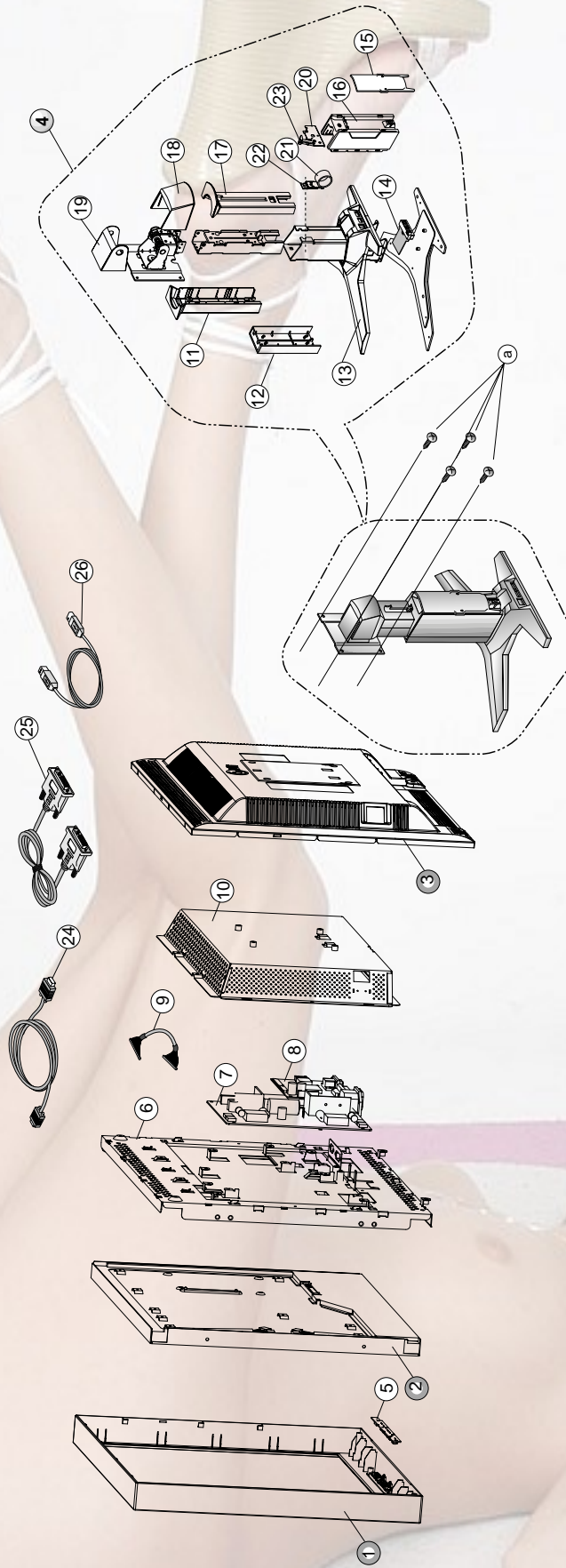

EXPLODED VIEW PARTS LIST

Ref. No.	Part No.	Description
1	3091TKL072E	CABINET ASSEMBLY, L1910PL BRAND L067 HF350U SILVER
2	6304FFT002A	LCD(LIQUID CRYSTAL DISPLAY), FLC48SXC8V-10 FUJITSU TFT COLOR SXGA 8BIT LVDS MVA
3	3809TKL051A	BACK COVER ASSEMBLY. L1910B,P L053 BRAND HF350U(87074)
4	3043TKK086K	TILT SWIVEL ASSEMBLY, L1910PL , HF350U 87074
5	6871TST415A	PWB(PCB) ASSEMBLY, SUB, L1910 L1810 CONTROL TOTAL BRAND CONTROL
6	4950TKS226A	METAL, FRAME MAIN L1910BL,PL
7	6871TPT245A or 6871TPT239B	PWB(PCB) ASSEMBLY, POWER, AI-0020 POWER TOTAL LIEN CHANG LHS93K FOR FUJITST PWB(PCB) ASSEMBLY, POWER, PWI1904S(JST WAFER) POWER TOTAL POWERNET LHS93K,LIPS FOR FUJITSU
8	6871TMT470A	PWB(PCB) ASSEMBLY, MAIN, L1910BL AFEUR BRAND CL-42 TOTAL
9	6631T11012W	CONNECTOR ASSEMBLY, 30P H-H 200MM UL20276 LG708G
10	4951TKS118A	METAL ASSEMBLY, SHIELD REAR L1910B
11	3550TKK220D	COVER, LB200A TOP FRONT POLYACETAL 87074
12	3550TKK218E	COVER, LB200A STAND FRONT ABS HF350U 87074
13	3550TKK222F	COVER, L1910PL BASE TOP HF350U 87074(USB)
14	6871TUT015A	PWB(PCB) ASSEMBLY, USB, LB886F SUB TOTAL BRAND CL-29
15	3550TKK223E	COVER, LB200A CABLE COVER ABS HF350U 87074
16	3550TKK219E	COVER, LB200A STAND REAR ABS HF350U 87074
17	3550TKK221D	COVER, LB200A TOP REAR POLYACETAL 87074
18	3550TKK217E	COVER, LB200A HINGE REAR ABS HF350U 87074
19	3550TKK216E	COVER, LB200A HINGE TOP ABS HF350U 87074
20	4950TKK346A	METAL, PLATE STOPPER, LB886F
21	3550TKK224C	COVER, LW900Z PIECE LOCK GN5008HF EK49
22	4970TKK008A	SPRING, COIL, PLATE NO DIM. FOR STAND T=0.45 LB886F
23	4950TKK345A	METAL, FIX SPRING, LB886FCABLE,
24	6850TD9004D	CABLE, D-SUB, UL 20276-9C(5.8MM)DT 1500MM GRAY(85964) LB500LDM
25	6866TDV004H	CABLE, DVI, UL20276 DT 2000MM GRAY(85964) LB886F DM
26	6866TDU002D	SIGNAL CABLE, UL20276SB10P+2C AWG#30 DT 1870MM GRAY(85964) BRAND
a	332-113E	SCREW, DRAWING, D3.0 L10.0 MSWR/BK-

REPLACEMENT PARTS LIST

CAUTION: BEFORE REPLACING ANY OF THESE COMPONENTS, READ CAREFULLY THE **SAFETY PRECAUTIONS** IN THIS MANUAL.

* NOTE : **S** SAFETY Mark **AL** ALTERNATIVE PARTS

DATE: 2003. 6. 19.				
*S	*AL	LOC. NO.	PART NO.	DESCRIPTION / SPECIFICATION
MAIN BOARD				
CAPACITORS				
		C204	OCK104CK56A	0.1UF 1608 50V 10% R/TP X7R
		C205	OCK104CK56A	0.1UF 1608 50V 10% R/TP X7R
		C206	OCK104CK56A	0.1UF 1608 50V 10% R/TP X7R
		C207	OCK104CK56A	0.1UF 1608 50V 10% R/TP X7R
		C208	OCK104CK56A	0.1UF 1608 50V 10% R/TP X7R
		C209	OCK104CK56A	0.1UF 1608 50V 10% R/TP X7R
		C210	OCK104CK56A	0.1UF 1608 50V 10% R/TP X7R
		C214	OCK104CK56A	0.1UF 1608 50V 10% R/TP X7R
		C215	OCK104CK56A	0.1UF 1608 50V 10% R/TP X7R
		C216	OCK104CK56A	0.1UF 1608 50V 10% R/TP X7R
		C217	OCK104CK56A	0.1UF 1608 50V 10% R/TP X7R
		C218	OCK104CK56A	0.1UF 1608 50V 10% R/TP X7R
		C219	OCK104CK56A	0.1UF 1608 50V 10% R/TP X7R
		C220	OCK104CK56A	0.1UF 1608 50V 10% R/TP X7R
		C221	OCK104CK56A	0.1UF 1608 50V 10% R/TP X7R
		C222	OCK104CK56A	0.1UF 1608 50V 10% R/TP X7R
		C223	OCK104CK56A	0.1UF 1608 50V 10% R/TP X7R
		C224	OCK104CK56A	0.1UF 1608 50V 10% R/TP X7R
		C225	OCK104CK56A	0.1UF 1608 50V 10% R/TP X7R
		C226	OCK104CK56A	0.1UF 1608 50V 10% R/TP X7R
		C227	OCK104CK56A	0.1UF 1608 50V 10% R/TP X7R
		C230	OCK104CK56A	0.1UF 1608 50V 10% R/TP X7R
		C231	OCK104CK56A	0.1UF 1608 50V 10% R/TP X7R
		C232	OCK104CK56A	0.1UF 1608 50V 10% R/TP X7R
		C233	OCK104CK56A	0.1UF 1608 50V 10% R/TP X7R
		C240	OCK104CK56A	0.1UF 1608 50V 10% R/TP X7R
		C244	OCK104CK56A	0.1UF 1608 50V 10% R/TP X7R
		C245	OCK104CK56A	0.1UF 1608 50V 10% R/TP X7R
		C246	OCK104CK56A	0.1UF 1608 50V 10% R/TP X7R
		C247	OCK104CK56A	0.1UF 1608 50V 10% R/TP X7R
		C248	OCK104CK56A	0.1UF 1608 50V 10% R/TP X7R
		C249	OCK104CK56A	0.1UF 1608 50V 10% R/TP X7R
		C250	OCK104CK56A	0.1UF 1608 50V 10% R/TP X7R
		C501	OCK104CK56A	0.1UF 1608 50V 10% R/TP X7R
		C502	OCC101CK41A	100PF 1608 50V 5% R/TP NP0
		C503	OCC101CK41A	100PF 1608 50V 5% R/TP NP0
		C505	OCC101CK41A	100PF 1608 50V 5% R/TP NP0
		C506	OCC101CK41A	100PF 1608 50V 5% R/TP NP0
		C507	OCK104CK56A	0.1UF 1608 50V 10% R/TP X7R
		C508	OCC101CK41A	100PF 1608 50V 5% R/TP NP0
		C509	OCC101CK41A	100PF 1608 50V 5% R/TP NP0
		C512	OCC180CK41A	18PF 1608 50V 5% R/TP NP0
		C513	OCC030CK01A	3PF 1608 50V 0.25 PF R/TP NP0
		C514	OCH8106F611	10UF 16V M 85STD(CYL) R/TP
		C516	OCK104CK56A	0.1UF 1608 50V 10% R/TP X7R
		C530	OCK103CK51A	0.01UF 1608 50V 10% R/TP B(Y5)
		C703	OCK104CK56A	0.1UF 1608 50V 10% R/TP X7R
		C704	OCC101CK41A	100PF 1608 50V 5% R/TP NP0
		C705	OCC680CK41A	68PF 1608 50V 5% R/TP NP0
		C706	OCC680CK41A	68PF 1608 50V 5% R/TP NP0
		C707	OCC680CK41A	68PF 1608 50V 5% R/TP NP0
		C708	OCK103CK51A	0.01UF 1608 50V 10% R/TP B(Y5)

DATE: 2003. 6. 19.				
*S	*AL	LOC. NO.	PART NO.	DESCRIPTION / SPECIFICATION
		C709	OCK103CK51A	0.01UF 1608 50V 10% R/TP B(Y5)
		C710	OCK103CK51A	0.01UF 1608 50V 10% R/TP B(Y5)
		C711	OCK103CK51A	0.01UF 1608 50V 10% R/TP B(Y5)
		C712	OCK104CK56A	0.1UF 1608 50V 10% R/TP X7R
		C713	OCC101CK41A	100PF 1608 50V 5% R/TP NP0
		C714	OCC101CK41A	100PF 1608 50V 5% R/TP NP0
		C727	OCK105CD56A	1UF 1608 10V 10% R/TP X7R
		C730	OCC101CK41A	100PF 1608 50V 5% R/TP NP0
		C731	OCC680CK41A	68PF 1608 50V 5% R/TP NP0
		C732	OCK103CK51A	0.01UF 1608 50V 10% R/TP B(Y5)
		C733	OCK104CK56A	0.1UF 1608 50V 10% R/TP X7R
		C734	OCK104CK56A	0.1UF 1608 50V 10% R/TP X7R
		C735	OCK104CK56A	0.1UF 1608 50V 10% R/TP X7R
		C736	OCK104CK56A	0.1UF 1608 50V 10% R/TP X7R
		C737	OCK104CK56A	0.1UF 1608 50V 10% R/TP X7R
		C738	OCK104CK56A	0.1UF 1608 50V 10% R/TP X7R
		C739	OCK104CK56A	0.1UF 1608 50V 10% R/TP X7R
		C740	OCE477EH618	470UF KMG 25V M FL TP 5
		C741	OCK104CK56A	0.1UF 1608 50V 10% R/TP X7R
		C742	OCK104CK56A	0.1UF 1608 50V 10% R/TP X7R
		C743	OCK104CK56A	0.1UF 1608 50V 10% R/TP X7R
		C744	OCK104CK56A	0.1UF 1608 50V 10% R/TP X7R
		C760	OCE107EF610	"100UF KMG,RD 16V 20% FL BULK"
		C801	OCK103CK51A	0.01UF 1608 50V 10% R/TP B(Y5)
		C802	OCK104CK56A	0.1UF 1608 50V 10% R/TP X7R
		C803	OCK105CD56A	1UF 1608 10V 10% R/TP X7R
		C804	OCC102CK41A	1000PF 1608 50V 5% R/TP NP0
		C809	OCK105CD56A	1UF 1608 10V 10% R/TP X7R
		C810	OCC102CK41A	1000PF 1608 50V 5% R/TP NP0
		C817	OCE107EF610	"100UF KMG,RD 16V 20% FL BULK"
		C818	OCK104CK56A	0.1UF 1608 50V 10% R/TP X7R
		C819	OCK103CK51A	0.01UF 1608 50V 10% R/TP B(Y5)
		C820	OCE107EF610	"100UF KMG,RD 16V 20% FL BULK"
		C821	OCK103CK51A	0.01UF 1608 50V 10% R/TP B(Y5)
		C822	OCK104CK56A	0.1UF 1608 50V 10% R/TP X7R
		C828	OCK104CK56A	0.1UF 1608 50V 10% R/TP X7R
		C829	OCK103CK51A	0.01UF 1608 50V 10% R/TP B(Y5)
		C831	OCE107EF610	"100UF KMG,RD 16V 20% FL BULK"
		C832	OCE107EF610	"100UF KMG,RD 16V 20% FL BULK"
DIODEs				
		D701	0DS226009AA	KDS226 TP KEC SOT-23 80V 300
		D702	0DS226009AA	KDS226 TP KEC SOT-23 80V 300
		D706	0DS226009AA	KDS226 TP KEC SOT-23 80V 300
		D707	0DD184009AA	KDS184 TP KEC - 85V - - - 300
		D708	0DS226009AA	KDS226 TP KEC SOT-23 80V 300
		D709	0DS226009AA	KDS226 TP KEC SOT-23 80V 300
		D710	0DS226009AA	KDS226 TP KEC SOT-23 80V 300
		D711	0DS226009AA	KDS226 TP KEC SOT-23 80V 300
		D712	0DS226009AA	KDS226 TP KEC SOT-23 80V 300
		D713	0DS226009AA	KDS226 TP KEC SOT-23 80V 300
		D714	0DS226009AA	KDS226 TP KEC SOT-23 80V 300
		D715	0DS226009AA	KDS226 TP KEC SOT-23 80V 300

DATE: 2003. 6. 19.				
*S	*AL	LOC. NO.	PART NO.	DESCRIPTION / SPECIFICATION
		D716	0DS226009AA	KDS226 TP KEC SOT-23 80V 300
		D717	0DS226009AA	KDS226 TP KEC SOT-23 80V 300
		D718	0DS226009AA	KDS226 TP KEC SOT-23 80V 300
		D719	0DD184009AA	KDS184 TP KEC - 85V - - - 300
		ZD701	0DZ560009GB	BZT52C5V6S DIODES R/TP SOD323
		ZD702	0DZ560009GB	BZT52C5V6S DIODES R/TP SOD323
		ZD703	0DZ560009GB	BZT52C5V6S DIODES R/TP SOD323
		ZD704	0DZ560009GB	BZT52C5V6S DIODES R/TP SOD323
		ZD705	0DZ560009GB	BZT52C5V6S DIODES R/TP SOD323
		ZD706	0DZ560009GB	BZT52C5V6S DIODES R/TP SOD323
		ZD707	0DZ560009GB	BZT52C5V6S DIODES R/TP SOD323
		ZD708	0DZ560009GB	BZT52C5V6S DIODES R/TP SOD323
		ZD709	0DZ560009GB	BZT52C5V6S DIODES R/TP SOD323
		ZD710	0DZ560009GB	BZT52C5V6S DIODES R/TP SOD323
		ZD711	0DZ560009GB	BZT52C5V6S DIODES R/TP SOD323
ICs				
		U201	OIPRPM3006A	MST9151 DUAL DVI-H MSTAR 128P
		U501	OIZZTSZ277A	MYSON 44P PLCC ST OTP L1910 -
		U502	OISG240860B	M24C08W6 SGS-THOMSON 8SOP R/T
		U503	OIPH740800H	"74F08D 14P,SOIC TP QUAD 2-INP"
		U702	OICS240213A	CAT24WC02J-TE13 8P SOP TP 2K
		U703	OICS240213A	CAT24WC02J-TE13 8P SOP TP 2K
		U802	OTFV180036A	SI3861DV VISHAY R/TP TSOP-6 4
		U803	OIPMGNS001D	LM1117MPX-2.5 NATIONAL SEMICO
		U804	OIPMGNS001E	LM1117MPX-3.3 NATIONAL SEMICO
		U805	OTFV180036A	SI3861DV VISHAY R/TP TSOP-6 4
TRANSISTOR				
		Q502	0TR390409AE	FAIRCHILD KST3904(LGEMTF) TP
		Q503	OIKE704200H	KIA7042AP TO-92 TP 4.2 VOLT.
		Q504	0TR390409AE	FAIRCHILD KST3904(LGEMTF) TP
		Q505	0TR390409AE	FAIRCHILD KST3904(LGEMTF) TP
		Q506	0TR390409AE	FAIRCHILD KST3904(LGEMTF) TP
		Q507	0TR390409AE	FAIRCHILD KST3904(LGEMTF) TP
		Q508	0TR390409AE	FAIRCHILD KST3904(LGEMTF) TP
		Q509	0TR390409AE	FAIRCHILD KST3904(LGEMTF) TP
		Q701	0TR390409AE	FAIRCHILD KST3904(LGEMTF) TP
		Q702	0TR390409AE	FAIRCHILD KST3904(LGEMTF) TP
		Q703	0TR390609FA	KST3906-MTF TP SAMSUNG SOT23
		Q704	0TR390609FA	KST3906-MTF TP SAMSUNG SOT23
		Q705	0TR390409AE	FAIRCHILD KST3904(LGEMTF) TP
		Q706	0TR390409AE	FAIRCHILD KST3904(LGEMTF) TP
		Q707	0TR390409AE	FAIRCHILD KST3904(LGEMTF) TP
RESISTORS				
		R201	0RJ0752D677	75 OHM 1/10 W 5% 1608 R/TP
		R202	0RJ0752D677	75 OHM 1/10 W 5% 1608 R/TP
		R203	0RJ0752D677	75 OHM 1/10 W 5% 1608 R/TP
		R204	0RJ1002D677	10K OHM 1/10 W 5% 1608 R/TP
		R205	0RJ1002D677	10K OHM 1/10 W 5% 1608 R/TP
		R207	0RJ4700D677	470 OHM 1/10 W 5% 1608 R/TP
		R208	0RJ0752D677	75 OHM 1/10 W 5% 1608 R/TP
		R209	0RJ0752D677	75 OHM 1/10 W 5% 1608 R/TP
		R210	0RJ0752D677	75 OHM 1/10 W 5% 1608 R/TP
		R211	0RJ0752D677	75 OHM 1/10 W 5% 1608 R/TP
		R212	0RJ0752D677	75 OHM 1/10 W 5% 1608 R/TP
		R213	0RJ0752D677	75 OHM 1/10 W 5% 1608 R/TP
		R214	0RJ0752D677	75 OHM 1/10 W 5% 1608 R/TP

DATE: 2003. 6. 19.				
*S	*AL	LOC. NO.	PART NO.	DESCRIPTION / SPECIFICATION
		R215	0RJ0752D677	75 OHM 1/10 W 5% 1608 R/TP
		R216	0RJ0752D677	75 OHM 1/10 W 5% 1608 R/TP
		R217	0RJ0752D677	75 OHM 1/10 W 5% 1608 R/TP
		R240	0RJ0752D677	75 OHM 1/10 W 5% 1608 R/TP
		R501	0RJ4701D677	4.7K OHM 1/10 W 5% 1608 R/TP
		R502	0RJ4701D677	4.7K OHM 1/10 W 5% 1608 R/TP
		R504	0RJ4701D677	4.7K OHM 1/10 W 5% 1608 R/TP
		R509	0RJ4701D677	4.7K OHM 1/10 W 5% 1608 R/TP
		R510	0RJ4700D677	470 OHM 1/10 W 5% 1608 R/TP
		R511	0RJ4700D677	470 OHM 1/10 W 5% 1608 R/TP
		R515	0RJ1002D677	10K OHM 1/10 W 5% 1608 R/TP
		R520	0RJ4701D677	4.7K OHM 1/10 W 5% 1608 R/TP
		R522	0RJ1000D677	100 OHM 1/10 W 5% 1608 R/TP
		R523	0RJ0332D677	33 OHM 1/10 W 5% 1608 R/TP
		R524	0RJ0332D677	33 OHM 1/10 W 5% 1608 R/TP
		R525	0RJ1002D677	10K OHM 1/10 W 5% 1608 R/TP
		R528	0RJ1000D677	100 OHM 1/10 W 5% 1608 R/TP
		R529	0RJ1000D677	100 OHM 1/10 W 5% 1608 R/TP
		R530	0RJ1000D677	100 OHM 1/10 W 5% 1608 R/TP
		R531	0RJ1000D677	100 OHM 1/10 W 5% 1608 R/TP
		R532	0RJ3301D677	3.3K OHM 1/10 W 5% 1608 R/TP
		R533	0RJ0332D677	33 OHM 1/10 W 5% 1608 R/TP
		R534	0RJ0332D677	33 OHM 1/10 W 5% 1608 R/TP
		R535	0RJ3301D677	3.3K OHM 1/10 W 5% 1608 R/TP
		R537	0RJ4701D677	4.7K OHM 1/10 W 5% 1608 R/TP
		R538	0RJ4701D677	4.7K OHM 1/10 W 5% 1608 R/TP
		R540	0RJ1002D677	10K OHM 1/10 W 5% 1608 R/TP
		R541	0RJ4702D677	4700 OHM 1/10 W 5% 1608 R/TP
		R542	0RJ1500D677	150 OHM 1/10 W 5% 1608 R/TP
		R551	0RJ4702D677	4700 OHM 1/10 W 5% 1608 R/TP
		R552	0RJ1001D677	1K OHM 1/10 W 5% 1608 R/TP
		R553	0RJ4701D677	4.7K OHM 1/10 W 5% 1608 R/TP
		R554	0RJ4701D677	4.7K OHM 1/10 W 5% 1608 R/TP
		R555	0RJ4701D677	4.7K OHM 1/10 W 5% 1608 R/TP
		R556	0RJ4701D677	4.7K OHM 1/10 W 5% 1608 R/TP
		R557	0RJ1001D677	1K OHM 1/10 W 5% 1608 R/TP
		R558	0RJ4701D677	4.7K OHM 1/10 W 5% 1608 R/TP
		R559	0RJ1001D677	1K OHM 1/10 W 5% 1608 R/TP
		R560	0RJ4701D677	4.7K OHM 1/10 W 5% 1608 R/TP
		R561	0RJ1000D677	100 OHM 1/10 W 5% 1608 R/TP
		R562	0RJ4700D677	470 OHM 1/10 W 5% 1608 R/TP
		R570	0RJ1001D677	1K OHM 1/10 W 5% 1608 R/TP
		R581	0RJ1000D677	100 OHM 1/10 W 5% 1608 R/TP
		R583	0RJ1000D677	100 OHM 1/10 W 5% 1608 R/TP
		R590	0RJ1000D677	100 OHM 1/10 W 5% 1608 R/TP
		R591	0RJ1000D677	100 OHM 1/10 W 5% 1608 R/TP
		R592	0RJ1000D677	100 OHM 1/10 W 5% 1608 R/TP
		R593	0RJ1000D677	100 OHM 1/10 W 5% 1608 R/TP
		R595	0RJ1000D677	100 OHM 1/10 W 5% 1608 R/TP
		R596	0RJ4701D677	4.7K OHM 1/10 W 5% 1608 R/TP
		R701	0RJ0752D677	75 OHM 1/10 W 5% 1608 R/TP
		R703	0RJ0752D677	75 OHM 1/10 W 5% 1608 R/TP
		R705	0RJ1000D677	100 OHM 1/10 W 5% 1608 R/TP
		R706	0RJ0752D677	75 OHM 1/10 W 5% 1608 R/TP
		R707	0RJ0272D677	27 OHM 1/10 W 5% 1608 R/TP
		R708	0RJ4700D677	470 OHM 1/10 W 5% 1608 R/TP
		R709	0RJ4700D677	470 OHM 1/10 W 5% 1608 R/TP
		R716	0RJ4701D677	4.7K OHM 1/10 W 5% 1608 R/TP
		R717	0RJ4701D677	4.7K OHM 1/10 W 5% 1608 R/TP
		R718	0RJ1000D677	100 OHM 1/10 W 5% 1608 R/TP
		R722	0RJ1000D677	100 OHM 1/10 W 5% 1608 R/TP
		R723	0RJ0332D677	33 OHM 1/10 W 5% 1608 R/TP

DATE: 2003. 6. 19.				
*S	*AL	LOC. NO.	PART NO.	DESCRIPTION / SPECIFICATION
		R724	0RJ0332D677	33 OHM 1/10 W 5% 1608 R/TP
		R725	0RJ4701D677	4.7K OHM 1/10 W 5% 1608 R/TP
		R726	0RJ1002D677	10K OHM 1/10 W 5% 1608 R/TP
		R727	0RJ1002D677	10K OHM 1/10 W 5% 1608 R/TP
		R728	0RJ0222D677	22 OHM 1/10 W 5% 1608 R/TP
		R729	0RJ0222D677	22 OHM 1/10 W 5% 1608 R/TP
		R730	0RJ1000D677	100 OHM 1/10 W 5% 1608 R/TP
		R731	0RJ4700D677	470 OHM 1/10 W 5% 1608 R/TP
		R732	0RJ4701D677	4.7K OHM 1/10 W 5% 1608 R/TP
		R733	0RJ1001D677	1K OHM 1/10 W 5% 1608 R/TP
		R734	0RJ4701D677	4.7K OHM 1/10 W 5% 1608 R/TP
		R739	0RJ0000D677	0 OHM 1/10 W 5% 1608 R/TP
		R740	0RJ1001D677	1K OHM 1/10 W 5% 1608 R/TP
		R741	0RJ4701D677	4.7K OHM 1/10 W 5% 1608 R/TP
		R744	0RJ4701D677	4.7K OHM 1/10 W 5% 1608 R/TP
		R745	0RJ4701D677	4.7K OHM 1/10 W 5% 1608 R/TP
		R747	0RJ4701D677	4.7K OHM 1/10 W 5% 1608 R/TP
		R748	0RJ4701D677	4.7K OHM 1/10 W 5% 1608 R/TP
		R750	0RJ1001D677	1K OHM 1/10 W 5% 1608 R/TP
		R751	0RJ1001D677	1K OHM 1/10 W 5% 1608 R/TP
		R753	0RJ1001D677	1K OHM 1/10 W 5% 1608 R/TP
		R754	0RJ4701D677	4.7K OHM 1/10 W 5% 1608 R/TP
		R755	0RJ4701D677	4.7K OHM 1/10 W 5% 1608 R/TP
		R756	0RJ0272D677	27 OHM 1/10 W 5% 1608 R/TP
		R757	0RJ4701D677	4.7K OHM 1/10 W 5% 1608 R/TP
		R758	0RJ0752D677	75 OHM 1/10 W 5% 1608 R/TP
		R759	0RJ0752D677	75 OHM 1/10 W 5% 1608 R/TP
		R761	0RJ0752D677	75 OHM 1/10 W 5% 1608 R/TP
		R762	0RJ4701D677	4.7K OHM 1/10 W 5% 1608 R/TP
		R763	0RJ1002D677	10K OHM 1/10 W 5% 1608 R/TP
		R764	0RJ1002D677	10K OHM 1/10 W 5% 1608 R/TP
		R765	0RJ0332D677	33 OHM 1/10 W 5% 1608 R/TP
		R766	0RJ0332D677	33 OHM 1/10 W 5% 1608 R/TP
		R767	0RJ1001D677	1K OHM 1/10 W 5% 1608 R/TP
		R768	0RJ1001D677	1K OHM 1/10 W 5% 1608 R/TP
		R769	0RJ0102D677	10 OHM 1/10 W 5% 1608 R/TP
		R770	0RJ0102D677	10 OHM 1/10 W 5% 1608 R/TP
		R771	0RJ0102D677	10 OHM 1/10 W 5% 1608 R/TP
		R772	0RJ0102D677	10 OHM 1/10 W 5% 1608 R/TP
		R773	0RJ0102D677	10 OHM 1/10 W 5% 1608 R/TP
		R774	0RJ0102D677	10 OHM 1/10 W 5% 1608 R/TP
		R803	0RJ0000D677	0 OHM 1/10 W 5% 1608 R/TP
		R811	0RJ2202D677	22K OHM 1/10 W 5% 1608 R/TP
		R812	0RJ5600D677	560 OHM 1/10 W 5% 1608 R/TP
		R813	0RJ2202D677	22K OHM 1/10 W 5% 1608 R/TP
		R814	0RJ5600D677	560 OHM 1/10 W 5% 1608 R/TP
		R840	0RJ0332D677	33 OHM 1/10 W 5% 1608 R/TP
		R841	0RJ0332D677	33 OHM 1/10 W 5% 1608 R/TP
		R842	0RJ0332D677	33 OHM 1/10 W 5% 1608 R/TP
		R843	0RJ0332D677	33 OHM 1/10 W 5% 1608 R/TP
		R844	0RJ0332D677	33 OHM 1/10 W 5% 1608 R/TP
		R845	0RJ0332D677	33 OHM 1/10 W 5% 1608 R/TP
		R846	0RJ0332D677	33 OHM 1/10 W 5% 1608 R/TP
		R847	0RJ0332D677	33 OHM 1/10 W 5% 1608 R/TP
		R848	0RJ0332D677	33 OHM 1/10 W 5% 1608 R/TP
		R849	0RJ0332D677	33 OHM 1/10 W 5% 1608 R/TP
		R854	0RJ0000D677	0 OHM 1/10 W 5% 1608 R/TP
		R855	0RJ0000D677	0 OHM 1/10 W 5% 1608 R/TP
OTHERs				
		X501	6212AA2004A	HC-49U TXC 12.0MHZ +/- 30 PPM

DATE: 2003. 6. 19.				
*S	*AL	LOC. NO.	PART NO.	DESCRIPTION / SPECIFICATION
CONTROL BOARD				
		LED1	0DLLT0208AA	LITEON LTST-C155KGJSKT R/TP G
		R1	0RJ4701D677	4.7K OHM 1/10 W 5% 1608 R/TP
		R2	0RJ4701D677	4.7K OHM 1/10 W 5% 1608 R/TP
		R3	0RJ8200D677	820 OHM 1/10 W 5% 1608 R/TP
		R4	0RJ8200D677	820 OHM 1/10 W 5% 1608 R/TP
		R5	0RJ1501D677	1.5K OHM 1/10 W 5% 1608 R/TP
		R6	0RJ1501D677	1.5K OHM 1/10 W 5% 1608 R/TP
		R7	0RJ2201D677	2200 OHM 1/10 W 5% 1608 R/TP
		R8	0RJ2201D677	2200 OHM 1/10 W 5% 1608 R/TP
		SW1	140-058E	SKHV10910B LGEC NON 12V 20A H
		SW2	140-058E	SKHV10910B LGEC NON 12V 20A H
		SW3	140-058E	SKHV10910B LGEC NON 12V 20A H
		SW4	140-058E	SKHV10910B LGEC NON 12V 20A H
		SW5	140-058E	SKHV10910B LGEC NON 12V 20A H
		SW6	140-058E	SKHV10910B LGEC NON 12V 20A H
		SW7	140-058E	SKHV10910B LGEC NON 12V 20A H
		SW8	140-058E	SKHV10910B LGEC NON 12V 20A H
USB BOARD				
		C1	0CH8107F611	100UF 16V M 85STD(CYL) R/TP
		C2	0CK103CK51A	0.01UF 1608 50V 10% R/TP B(Y5
		C6	0CH3105F946	1UF 16V Z F 2012 R/TP
		C8	0CC150CK41A	15PF 1608 50V 5% R/TP NP0
		C9	0CC150CK41A	15PF 1608 50V 5% R/TP NP0
		C18	0CK104CK56A	0.1UF 1608 50V 10% R/TP X7R
		C23	0CH8107F611	100UF 16V M 85STD(CYL) R/TP
		C24	0CC470CK41A	47PF 1608 50V 5% R/TP NP0
		C25	0CC470CK41A	47PF 1608 50V 5% R/TP NP0
		C27	0CH8107F611	100UF 16V M 85STD(CYL) R/TP
		C28	0CK103CK51A	0.01UF 1608 50V 10% R/TP B(Y5
		C31	0CK104CK56A	0.1UF 1608 50V 10% R/TP X7R
		C32	0CK104CK56A	0.1UF 1608 50V 10% R/TP X7R
		C37	0CH8107F611	100UF 16V M 85STD(CYL) R/TP
		C38	0CC470CK41A	47PF 1608 50V 5% R/TP NP0
		C39	0CC470CK41A	47PF 1608 50V 5% R/TP NP0
		D1	0DS181009AA	KDS181 TP KEC SOT-23 80V 30
		L4	6210TCE001P	HB-1S2012-121JT CERATECH 2012
		L5	6210TCE001P	HB-1S2012-121JT CERATECH 2012
		L13	6210TCE001B	HH-1H3216-500JT CERATEC 3216M
		L14	6210TCE001P	HB-1S2012-121JT CERATECH 2012
		L15	6210TCE001P	HB-1S2012-121JT CERATECH 2012
		L16	6210TCE001P	HB-1S2012-121JT CERATECH 2012
		L17	6210TCE001P	HB-1S2012-121JT CERATECH 2012
		L18	6210TCE001B	HH-1H3216-500JT CERATEC 3216M
		L19	6210TCE001P	HB-1S2012-121JT CERATECH 2012
		L20	6210TCE001P	HB-1S2012-121JT CERATECH 2012
		R1	0RJ0000D677	0 OHM 1/10 W 5% 1608 R/TP
		R2	0RJ1001D677	1K OHM 1/10 W 5% 1608 R/TP
		R8	0RJ1002D677	10K OHM 1/10 W 5% 1608 R/TP
		R9	0RJ1501D677	1.5K OHM 1/10 W 5% 1608 R/TP
		R19	0RJ1502D677	15K OHM 1/10 W 5% 1608 R/TP
		R21	0RJ0222D677	22 OHM 1/10 W 5% 1608 R/TP
		R22	0RJ0222D677	22 OHM 1/10 W 5% 1608 R/TP
		R23	0RJ1502D677	15K OHM 1/10 W 5% 1608 R/TP
		R24	0RJ1502D677	15K OHM 1/10 W 5% 1608 R/TP
		R25	0RJ0000D677	0 OHM 1/10 W 5% 1608 R/TP
		R26	0RJ1002D677	10K OHM 1/10 W 5% 1608 R/TP
		R28	0RJ0222D677	22 OHM 1/10 W 5% 1608 R/TP
		R30	0RJ0222D677	22 OHM 1/10 W 5% 1608 R/TP
		R31	0RJ1502D677	15K OHM 1/10 W 5% 1608 R/TP

DATE: 2003. 6. 19.

*S	*AL	LOC. NO.	PART NO.	DESCRIPTION / SPECIFICATION
		R32	0RJ1502D677	15K OHM 1/10 W 5% 1608 R/TP
		R34	0RJ0222D677	22 OHM 1/10 W 5% 1608 R/TP
		R35	0RJ0222D677	22 OHM 1/10 W 5% 1608 R/TP
		R37	0RJ1501D677	1.5K OHM 1/10 W 5% 1608 R/TP
		R40	0RJ1501D677	1.5K OHM 1/10 W 5% 1608 R/TP
		R41	0RJ1002D677	10K OHM 1/10 W 5% 1608 R/TP
		U1	0IRH033200A	BA033FP-E2 MOLD-3 TP REGULATO
		U2	0IPRPT1007A	TUSB2036 TEXAS INSTRUMENT 32P
		U3	0ITI204200B	TPS2042ADR TEXAS INSTRUMENT 8
		X1	6202TST001C	"SX-1, SUNNY SMD, 6.0MHZ ,50PP"
		ZD1	0DZ560009DA	UDZ S 5.6B TP ROHM-K SOD323 2
		ZD4	0DZ560009DA	UDZ S 5.6B TP ROHM-K SOD323 2
		ZD7	0DZ560009DA	UDZ S 5.6B TP ROHM-K SOD323 2
		ZD8	0DZ560009DA	UDZ S 5.6B TP ROHM-K SOD323 2
		ZD11	0DZ560009DA	UDZ S 5.6B TP ROHM-K SOD323 2
		ZD12	0DZ560009DA	UDZ S 5.6B TP ROHM-K SOD323 2

PIN CONFIGURATION

MST9151 DUAL MSTAR 128P

PIN DIAGRAM

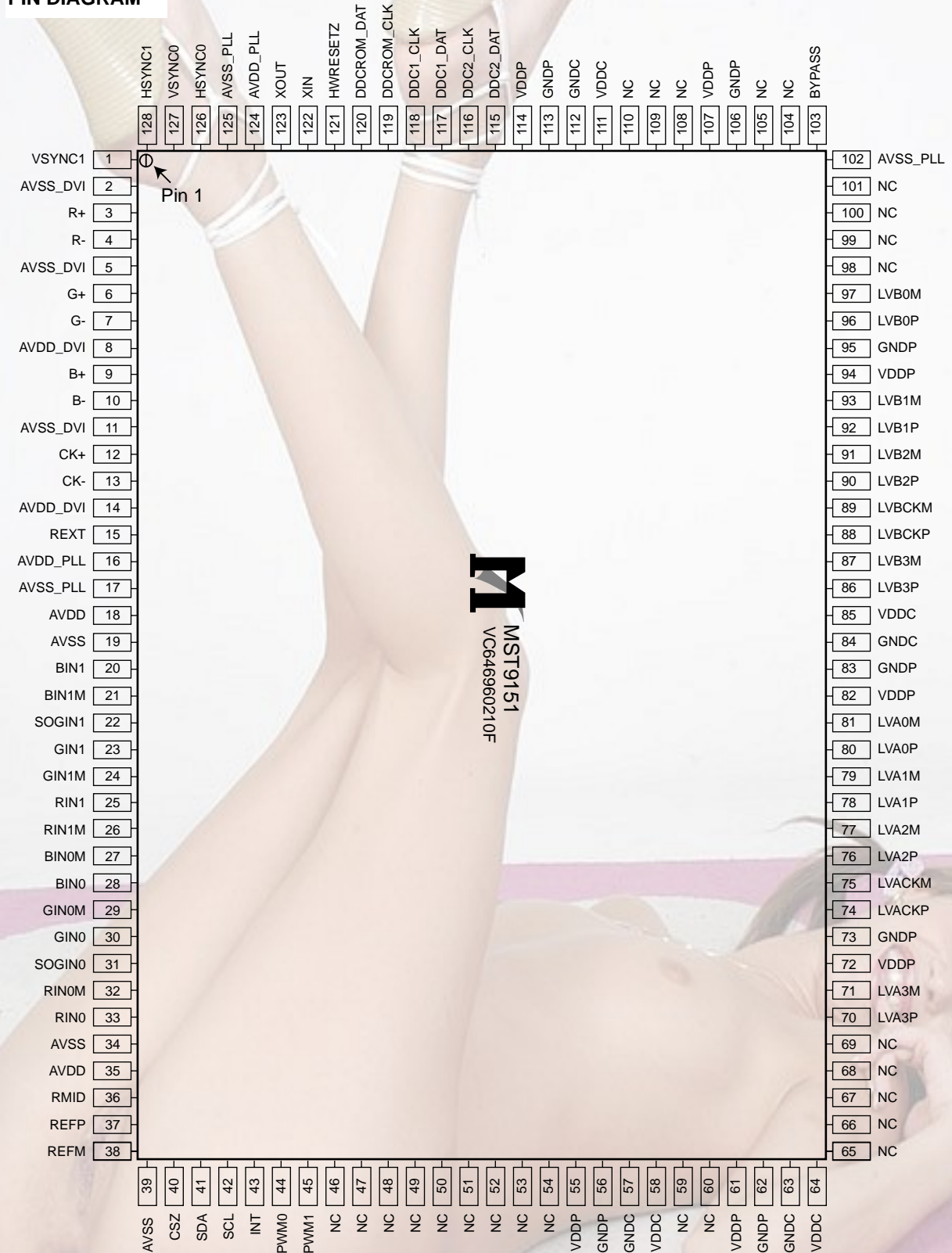

M
MST9151
VC646960210F

2. MICOM

2 L1910
MICOM

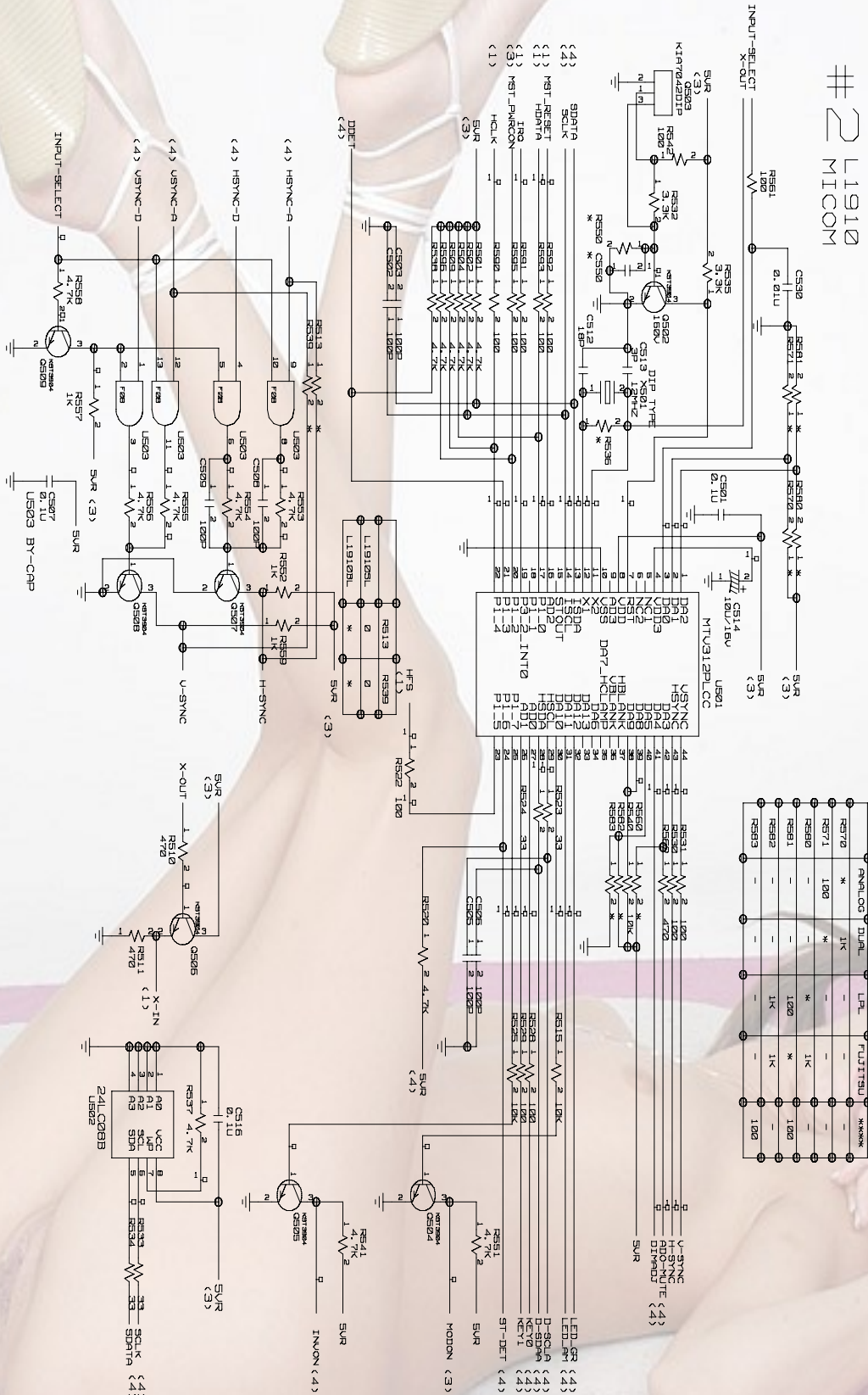

3. POWER

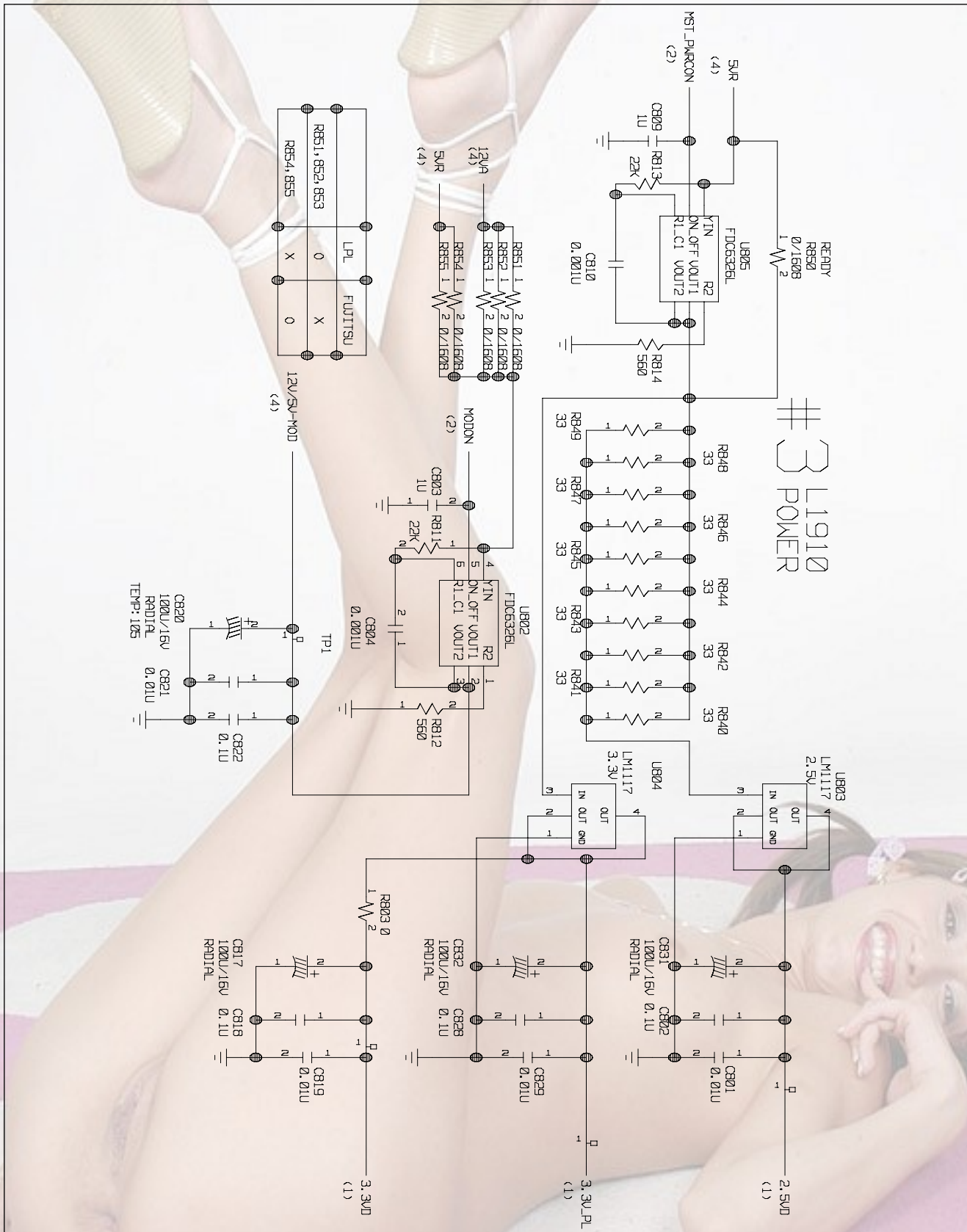

4. CONNECTOR/JACKS

4 1910 CONNECTOR & JACKS

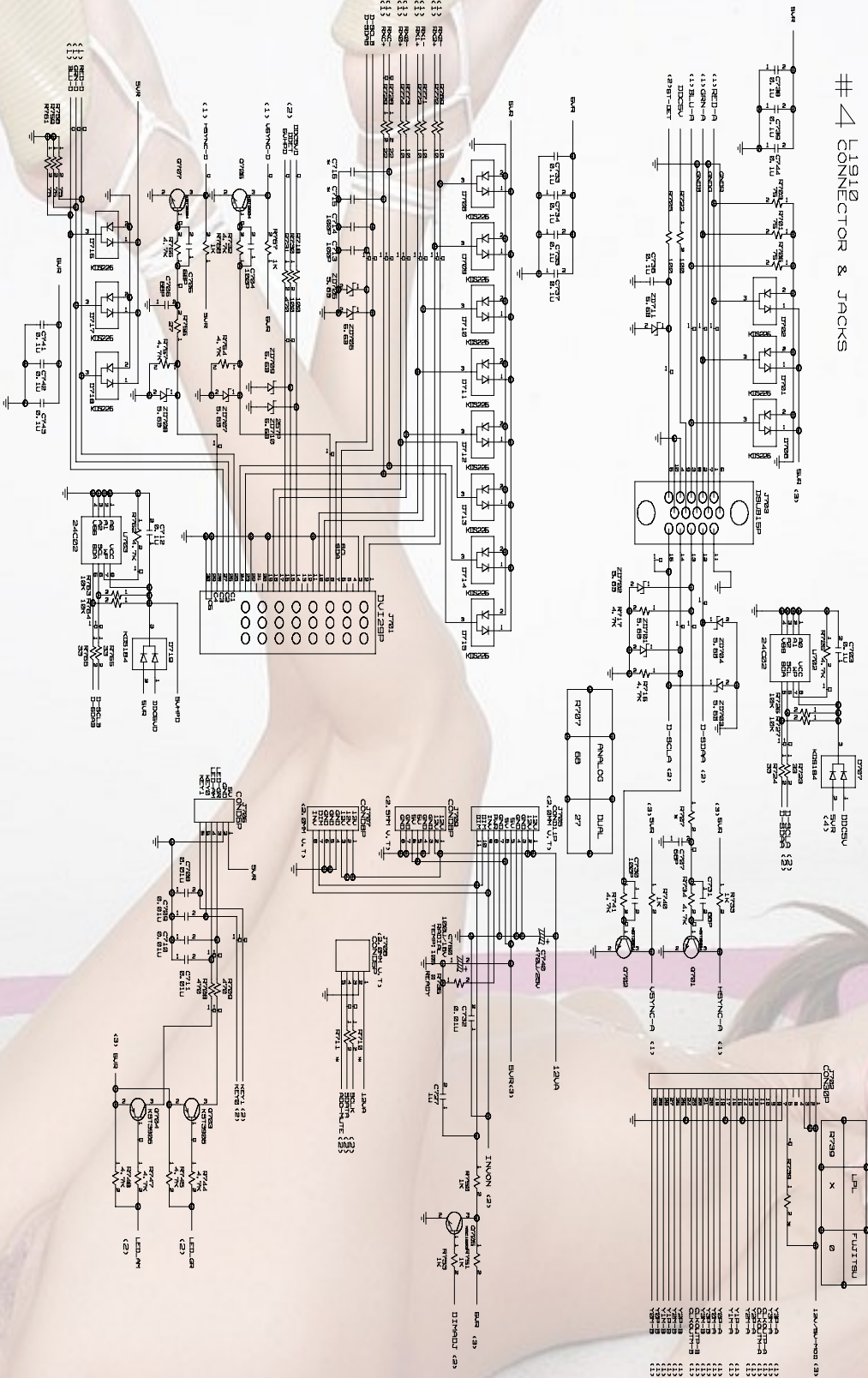

5. KEY PART

LB700L KEY PART
2003. 02. 24

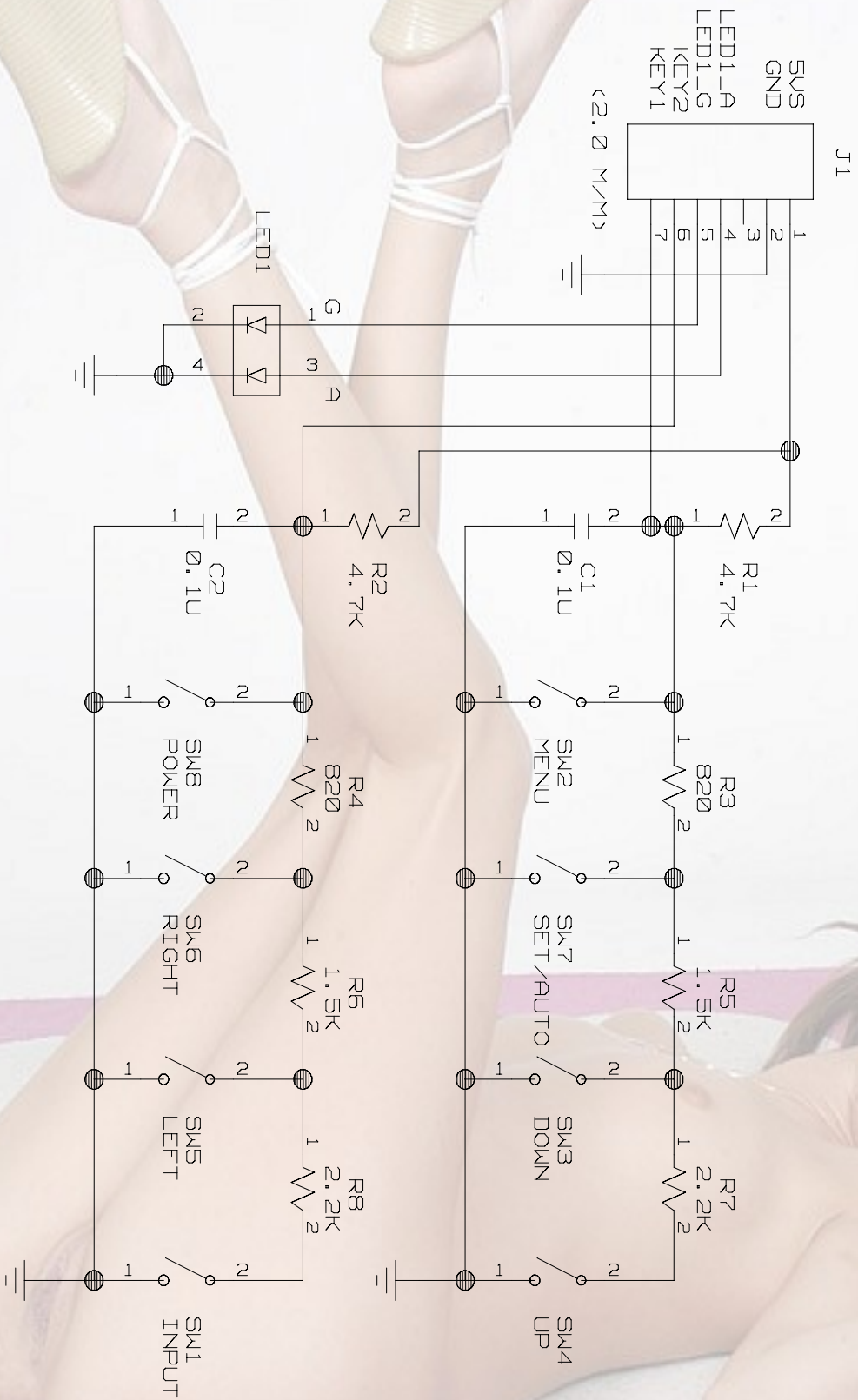

6. USB

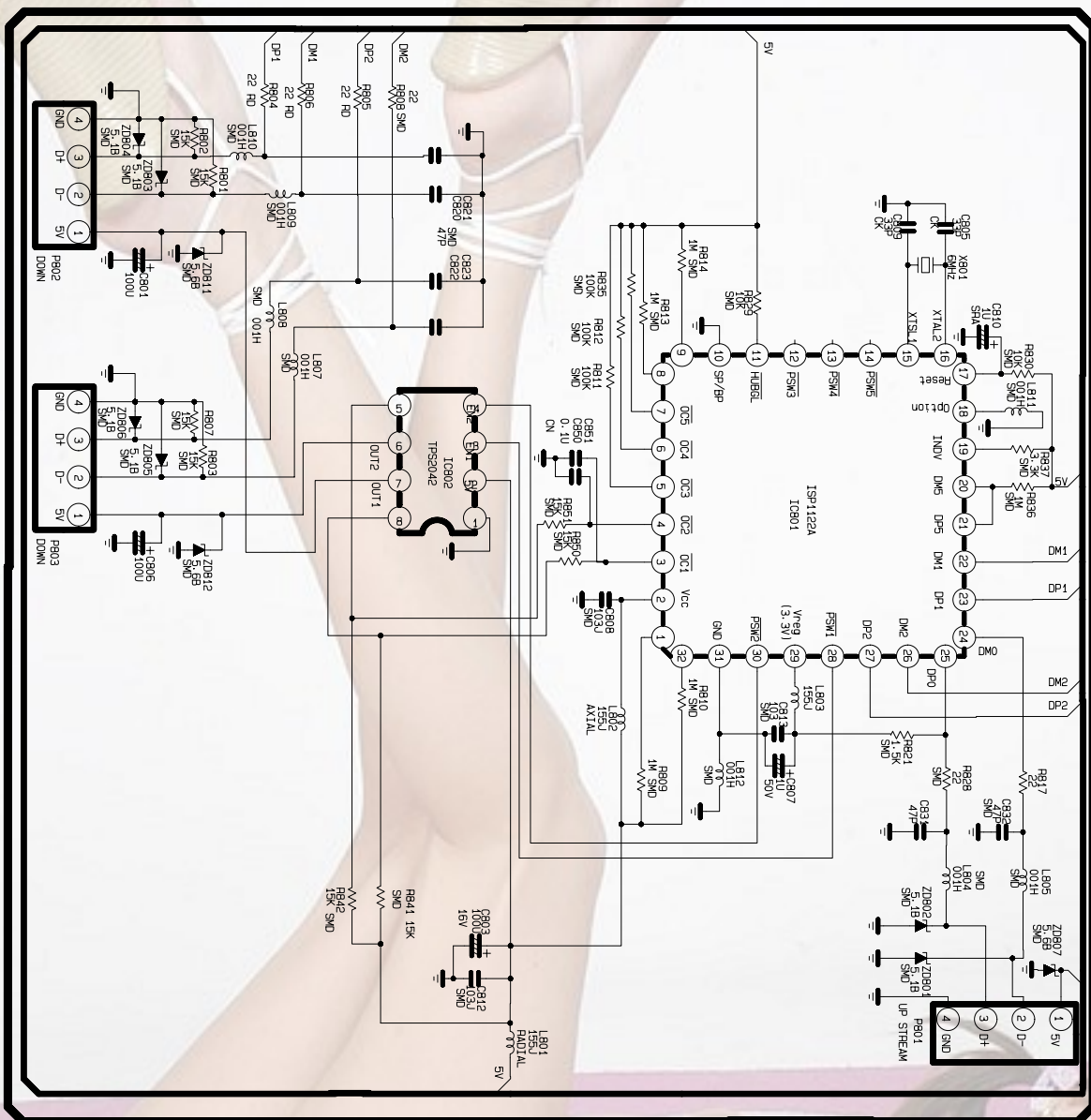

THE Δ SYMBOL MARK OF THIS SCHEMATIC DIAGRAM INCORPORATES SPECIAL FEATURES IMPORTANT FOR PROTECTION FROM X-RADIATION, FIRE AND ELECTRICAL SHOCK HAZARDS. WHEN SERVICING IT IS ESSENTIAL THAT ONLY MANUFACTURERS SPECIFIED PARTS BE USED FOR THE CRITICAL COMPONENTS IN THE Δ SYMBOL MARK OF THE SCHEMATIC. COMPANY CONFIDENTIAL DO NOT COPY!

DATE	2003.02.03	REV	01
MODEL	L1710L-USB	Sheet	1 / 1 Page

7. LIPS

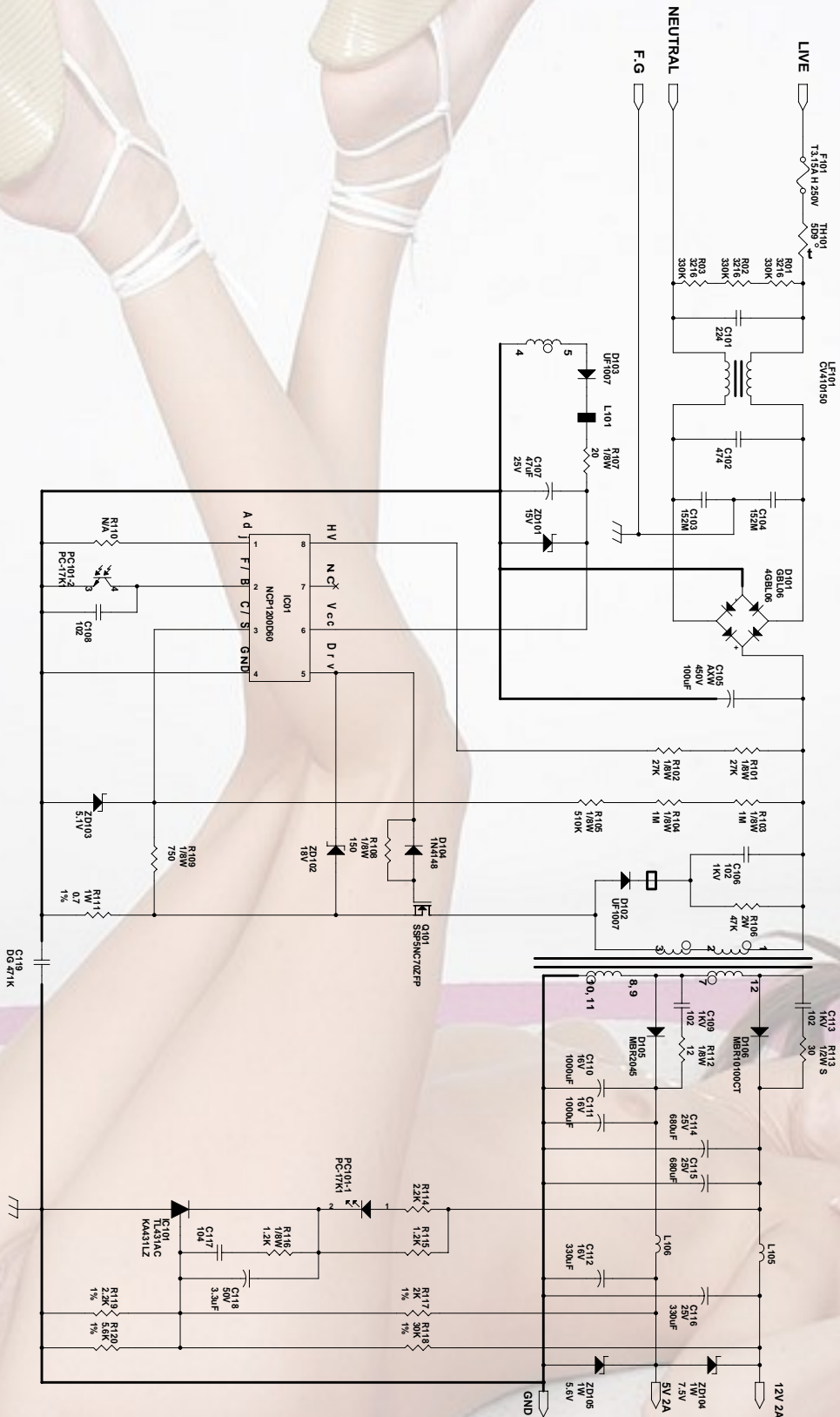

8. LIPS

PWM1904S

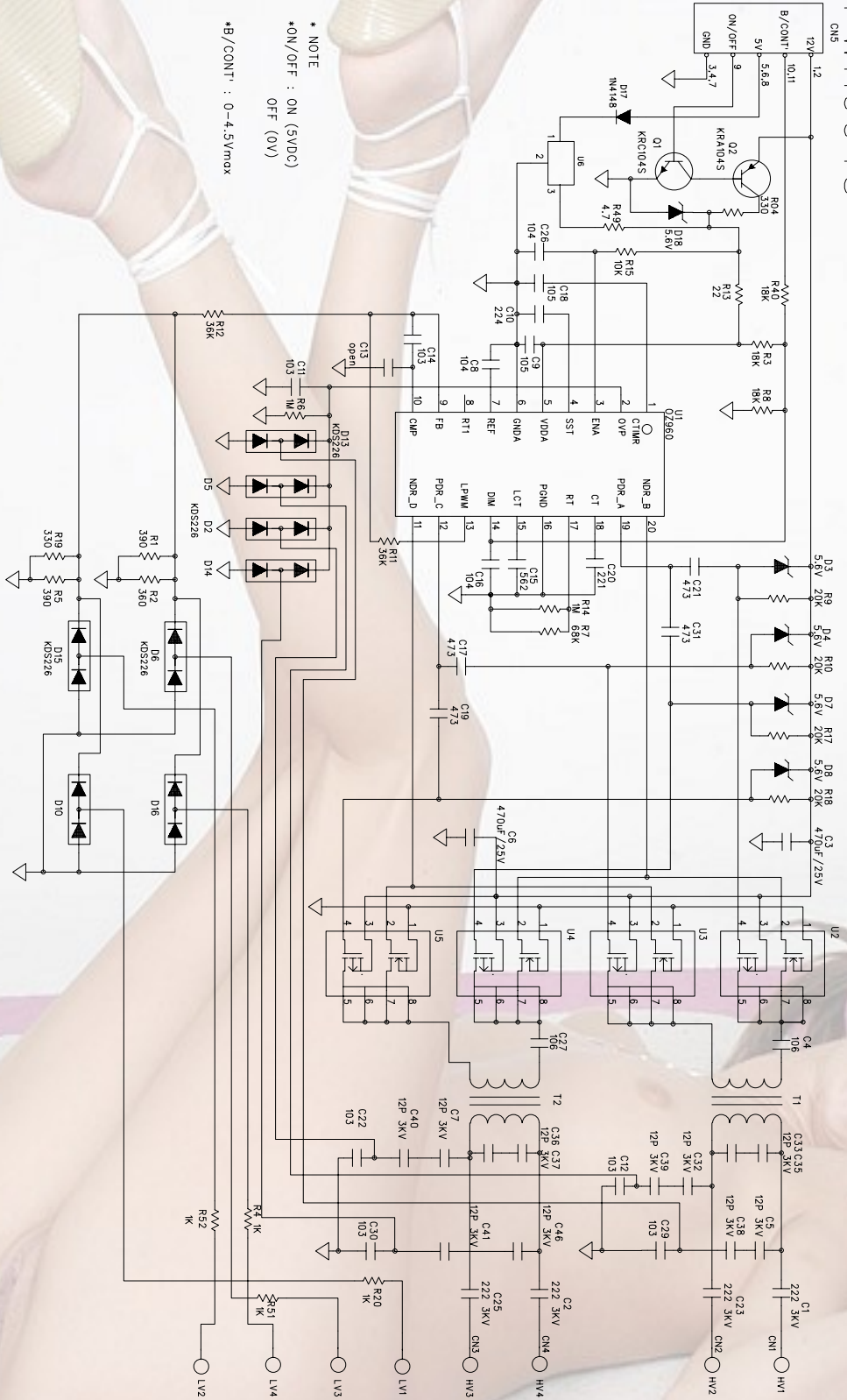

- * NOTE
- *ON/OFF : ON (5VDC)
- OFF (0V)
- *B/CONT : 0-4.5Vmax



P/NO : 3828TSL095C

Jul. 2003
Printed in Korea

