

Service Manual

LCD Monitor Acer AL1717

Service Manual Versions and Revision

No.	Version	Release Date	Revision
1	1.0	2006/03/23	Initial Release

Copyright

Copyright 2006 InnoLux Tech. Corp. Ltd

All Rights Reserved

This manual may not, in whole or in part, be copied, Photocopied, reproduced, translated, or converted to any electronic or machine readable form without prior written permission of InnoLux Tech. Corp. Ltd.

Acer AL1717 Service Manual

Table of Contents

CHAPTER 1- PRECAUTIONS & SAFETY NOTICES	3
1. SAFETY PRECAUTIONS	3
2. PRODUCT SAFETY NOTICE	3
3. SERVICE NOTES.....	3
CHAPTER 2- SERVICE TOOLS & EQUIPMENT REQUIRED	4
CHAPTER 3- CIRCUIT THEORY	5
2. INTERFACE BOARD DIAGRAM	5
3. ELECTRONIC CIRCUIT THEORY.....	6
CHAPTER 4- DISASSEMBLY & ASSEMBLY	錯誤! 尚未定義書籤。
1. EXPLODED DIAGRAM	錯誤! 尚未定義書籤。
2. DISASSEMBLY BLOCK	錯誤! 尚未定義書籤。
3. ASSEMBLY BLOCK.....	錯誤! 尚未定義書籤。
CHAPTER 5- TEST AND ADJUSTMENT	13
1. GENERAL POINTS	13
1.1 TEST EQUIPMENT OR TOOL	13
1.2 PRESET TEST PATTERN	13
1.3 AC INPUT	13
1.4 OBSERVATION DISTANCE	13
1.5 KEY FUNCTION DESCRIPTION	13
1.6 BURN-IN (AGING) PATTERN	14
1.7 WARM UP	14
2. INPUT SIGNAL	14
2.1 VIDEO SIGNAL INPUT	14
3. FUNCTION CHECK	15
3.1 OSD FUNCTION TEST	15
3.2 SCREEN PICTURE CHECK	15
3.3 AUTO COLOR BALANCE	15
3.4 TIMING CHECK	15
3.5 POWER CONSUMPTION FUNCTION TEST	15
3.6 VGA CABLE DETECT TEST	16
3.7 HI-POT TEST	16
3.8 GROUNDING TEST	16
3.9 BUMPING TEST	16
4. DISPLAY CHECK	16
4.1 PANEL FLICKER CHECK	16
4.2 PANEL DEFECT INSPECTION	16
5. PICTURE CHECK	17
5.1 CHECK BRIGHTNESS UNIFORMITY	17
5.2 COLOR TEMPERATURE CHECK	18
5.3 BRIGHTNESS OUT (VIDEO SIGNAL INPUT 700MV ± 2%)	18
5.4 DDC DATA CHECK	18
6. AUDIO CHECK	19
6.1 AUDIO SOUND CHECK	19
6.2 AUDIO CONTROL TEST	19
CHAPTER 6- TROUBLE SHOOTING	20
ATTACHMENT 1- BILL OF MATERIAL	26
ATTACHMENT 2- SCHEMATIC	31
ATTACHMENT 3- PCB LAYOUT	40

Chapter 1- PRECAUTIONS & SAFETY NOTICES

1. SAFETY PRECAUTIONS

This monitor is manufactured and tested on a ground principle that a user's safety comes first. However, improper used or installation may cause damage to the monitor as well as to the user.

WARNINGS:

- This monitor should be operated only at the correct power sources indicated on the label on the rear of the monitor. If you're unsure of the power supply in you residence, consult your local dealer or Power Company.
- Do not try to repair the monitor by yourself, as it contains no user-serviceable parts. This monitor should only be repaired by a qualified technician.
- Do not remove the monitor cabinet. There are high-voltage parts inside that may cause electric shock to human bodies.
- Stop using the monitor if the cabinet is damaged. Have it checked by a service technician.
- Put your monitor only in a lean, cool, dry environment. If it gets wet, unplug the power cable immediately and consult your closed dealer.
- Always unplug the monitor before cleaning it. Clean the cabinet with a clean, dry cloth. Apply non-ammonia based cleaner onto the cloth, not directly onto the class screen.
- Do not place heavy objects on the monitor or power cord.

2. PRODUCT SAFETY NOTICE

Many electrical and mechanical parts in this chassis have special safety visual inspections and the protection afforded by them cannot necessarily be obtained by using replacement components rated for higher voltage, wattage, etc. Before replacing any of these components read the parts list in this manual carefully. The use of substitute replacement parts, which do not have the same safety characteristics as specified in the parts list, may create shock, fire, or other hazards.

3. SERVICE NOTES

- When replacing parts or circuit boards, clamp the lead wires around terminals before soldering.
- Keep wires away from high voltage, high temperature components and sharp edges.
- Keep wires in their original position so as to reduce interference.
- Adjustment of this product please refers to the user' manual.

Chapter 2- SERVICE TOOLS & EQUIPMENT REQUIRED

1. SIGNAL GENERATOR
2. MULTIMETER
3. SCREW DRIVER
4. OSCILLOSCOPE
5. Soldering IRON
6. SOLDER
7. VGA Cable (15pins point to point)
8. DVI Cable(DVI-D 24+1 pin)
9. Color Analyzer
10. Myson412 ISP Board
11. EDID Board
12. EDID program file

Chapter 3- CIRCUIT THEORY

1. Monitor Block Diagram

The LCD Monitor contains an interface board, and inverter/power/Audio board, keypad board and flat panel. In Inverter/power/Audio board, power section supplies +14V & +5V for Inverter/Audio and Interface board used. The inverter section drives the backlight of panel and the DC-DC conversion. The Audio section drives speaker (2 x1W).

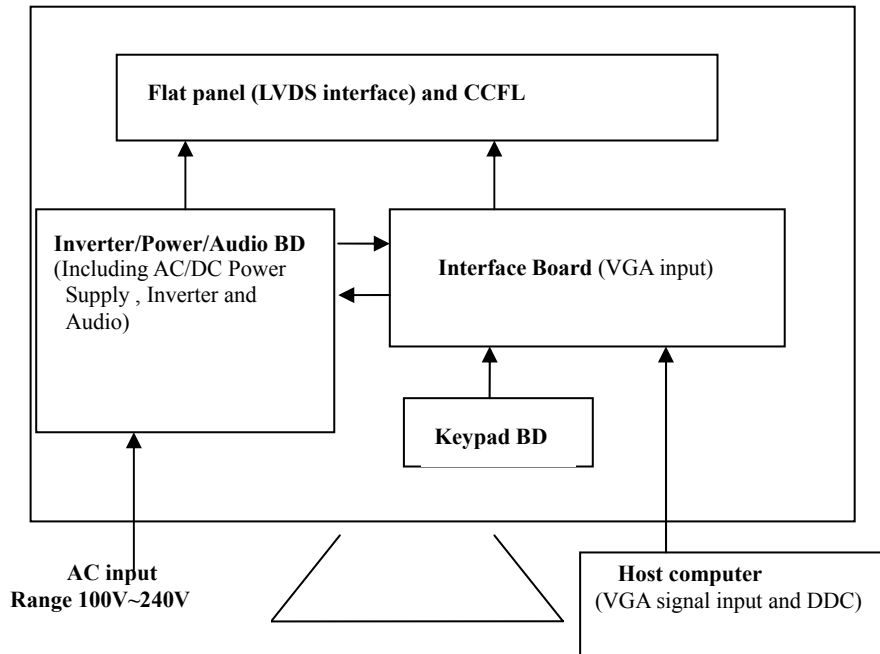

2. Interface BOARD DIAGRAM

Interface Board

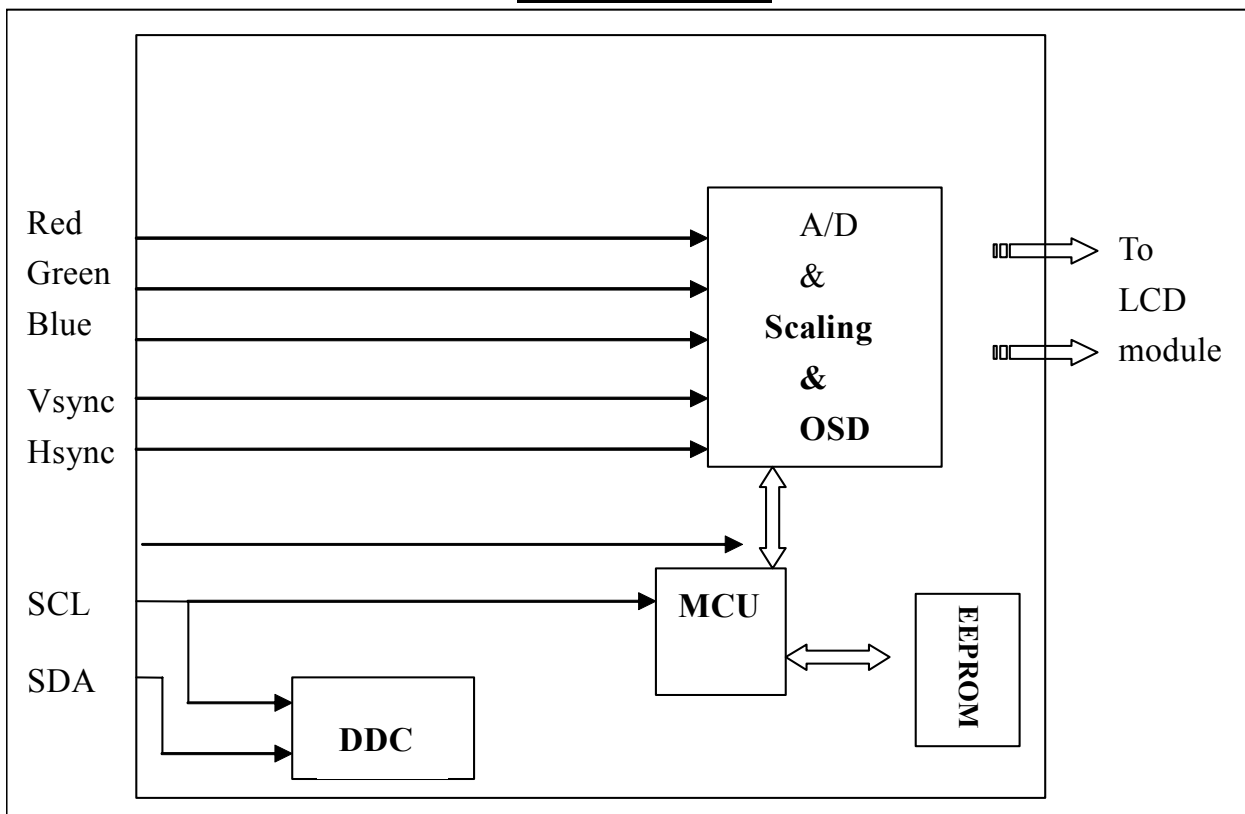

3. Electronic Circuit Theory

3.1 Switching Mode Power Supply

3.1.1 AC Current Input Circuit

P801 is a connector for connecting AC Power. F801 is a fuse to protect all the circuit. AC input voltage is from 90v to 264V. R820 and R821 joined between two inputting main circuit to prevent man from shock. L801 is used to clear up low frequency wave. C801 and C806 are used to discharge the waves that L801 produced. High frequency waves are damped by C801 and C806. D801 is a rectifier which composed of 4 build-in diodes, it inverts AC to DC.

3.1.2 High Voltage to Low Voltage Control Circuit

C805 is used to smooth the wave from rectifier. IC802 is a highly integrated PWM controller which build-in power MOSFET. When rectified DC high voltage is applied to the DRAIN pin during start-up, the MOSFET is initially off, and the CONTROL pin capacitor is charged through a switched high voltage current source connected internally between the DRAIN and CONTROL pins. When the CONTROL pin voltage V_c reaches approximately 5.8V, the control circuitry is activated and the soft-start begins. The soft-start circuit gradually increases the duty cycle of the MOSFET from zero to the maximum value over approximately 10ms. If no external feedback/supply current is fed into the CONTROL pin by the end of the soft-start, the high voltage current source is turned off and the CONTROL pin will start discharging in response to the supply current drawn by the control circuitry.

Resistor R803, R807, R824 and R825 are for line over voltage shutdown(OV) and line under-voltage detection(UV).

Resistors R801, R805, R822, R823 are for external current limit adjustment. And used to reduce the current limit externally to a value close to the operating peak current of primary about 1.35A. The mean is power will protected when the primary current over about 1.35A.

When PWM is turned off, the main current flow will be consumed through D804, and ZD802, This will prevent MOSFET which built-in IC802 from being damaged under large current impulse and voltage spike.

D806 and C815 to provide internal Auxiliary current to CONTROL pin during normal operation. Otherwise, error amplifier and feedback current input the CONTROL pin for duty cycle control.

3.1.3 DC 5V and DC 14V Output Circuit

For DC 5V, D805 is used to rectify the inducted current. R806 and C811 are used to store energy when current is reversed. The parts including C814, C814, C822, C821, B801 and L803 are used to smooth the current waves.

For DC 14V, D803 is used to rectify the inducted current. R802 and C802 are used to store energy when current is reversed. The parts including C808, C810 and L802 are used to smooth the current waves.

3.1.4 Feedback and OVP Protect Circuit

Pin R of IC803 is supplied 2.5-v stable voltage. It connects to 5V and 14V output through R811, R810 and R818. R811, R810 and R818 are output sampling resistor. When the sampling voltage more than 2.5V or less than 2.5V, current of FB IC802 will change, this can change the voltage from T801.

For 5VDC output OVP, ZD803 is a Zener Diode, when 5 voltage up to 5.6V, the zener current cause R819 voltage to ground is up to 0.7V, Q801 being triggered and OVP working. For 14VDC output OVP, ZD804 is a Zener Diode, when 14 voltage up to 18V, the Zener current cause R819 voltage to ground is up to 0.7V, Q801 being triggered and OVP working. The current of potential is used to make build-in diode light. Current of FB to IC802 will be changed, this can change the voltage from T801.

Q802, R827, R828 and ZD801 make up of dummy loading circuit. For start-up sequence, during 5V output take place high loading first, this dummy loading circuit operated to insure 14V not be increased.

3.2 I/F Board Circuit

3.2.1 RGB CAPTURE

- Signal RED, GREEN, BLUE input through CN103 #1, #2, #3, Stop DC via C112, C114 and C116, and then enter into U105 (TSUM56AL) analog input terminal #18, #20, #23, and then

TSUM56AL deals with signal internally. TVS101, TVS102, TVS103 are ESD protector to prevent U105 from ESD.

- Signal DDC_SCL (series clock) inputs via CN103#15, and then passes through ZD101 Zener for ESD protection, goes into U105 #31.
- Signal DDC_SDA (series data) inputs via CN103#12, and then passes through ZD107 Zener for ESD protection, goes into U105 #30.
- Signal TTL vertical sync. (Vsync) inputs via CN103 #14, and then clamped by ZD105 Zener, passes through R129, and then goes into IC U105 (TSUM56AL) #28.
- Signal TTL horizontal sync. (Hsync) inputs via CN103 #13, and then clamped by ZD106 Zener, passes through FB101, R130, and then goes into IC U105 (TSUM56AL) #27.
- CN103#5 is defined as cable detect pin, this detector realize passes through R122 Pull high, go into U105#35.
- U103 power is supplied by PC via CN103#9, or supplied by Monitor self via D103.
- U103 is an EEPROM IC which is memory and EDID data saved in it.

3.2.2 Buttons Control

- Button “Power” on right side bezel connects to U105 (TSUM56AL) #88 through R161, via CN105#4.
- Button “UP” “DOWN” “MENU” “AUTO” on right side bezel connects to U105 (TSUM56AL) #91, #90, #89, #92 through R158, R159, R160, R157, via CN105 #7, #6, #5, #8.
- U108 is an EEPROM IC which memory OSD setting and save the value adjusted by user.
- LED Indicator on Front Bezel
 - a. When press button “power”, U105 (TSUM56AL) #42 sends out a low potential, via R188, flow to CN105 #2 on keypad, LED Blue ON.
 - b. When in “Suspend” mode, U105 (TSUM56AL) #41 sends out a low potential, via R189, flows to CN105 #1 on keypad, LED Amber ON.

3.2.3 Mstar CHIP U105 (TSUM56AL)

- U105 (TSUM56AL) #54. #55. #58~#65 output 8 bit even LVDS digital data to panel control circuit through CN104.
- U105 (TSUM56AL) #67~#74. #77. #78 output 8 bit odd LVDS digital data to panel control circuit through CN104.
- U105 (TSUM56AL) #86 outputs Brightness “PWM” signals to control CCFL brightness.
- U105 (TSUM56AL) #48 output PPWR ”H” potential to make Q103 conducted, and then make Q101 conducted, +5V flow to CN104#1~#3 as Panel VDD .
- U105 (TSUM56AL) #85 output CCFL_ON/OFF ”H” potential to control Inverter on/off.
- TCLK by Crystal 14.318MHz input to U105 (TSUM56AL) #96, #97.
Please refer to TSUM56AL Pin Assignments table in page

3.2.4 Regulator Circuit

- +5V is from switching mode power supply for Panel used.
- +3.3V generates from +5V through C101 and C103 filtering and U101 which is output +3.3V LDO for U103, U106, U108 and U105 used.
- +1.8V generates from +5V through C101 and C103 filtering and U102 which is output +1.8V LDO, for U105 used.

3.2.5 Audio circuit

- Audio Signal R,L,GND input through P701, #2, #5, #1, Stop DC via C711, C712, and then enter into U701 (TDA7496L) analog input terminal #4, #9.
- U701 (TDA7496L) #14, #17 output R,L audio data to Speaker through CN701.
- U105 (TSUM56AL) #94 output MUTE “H” potential to control U701 on/off.
- U105 (TSUM56AL) #93 outputs Volume “PWM” signals to control U701 Volume.

4. Inverter circuit

4.1 Low voltage to high voltage circuit

14VDC provides the power for IC501; the control signals Brightness and ON/OFF come from I/F board. ON/OFF signal connect to pin8 of IC501 and makes IC501 enable. Brightness signal connect to pin7 of IC501 and regulates the panel brightness, R526, D515, R529, C505 make up a network of delaying time circuit and R523, R524 make up a divided voltage network, C504 is used to dump noise. The operation frequency is determined by the external Resistor R522 and capacitor C529 connected to pin5 of IC501. BURST MODE dimming pulse frequency and duty is regulated by I/F board. C503 is used for soft start and compensation, C502, C528 are used for dump noise.

The output drives, include NDR4, NDRV2, PDRV3, PDRV1 (pins1, 3, 15, 16 respectively) output square pulses to drive MOSFET U501, U502, and each of U501, U502 is consist of a N channel MOSFET and a P channel MOSFET. U501 and U502 work as full-bridge topology, it is high efficient, zero voltage switching.

During start up, VSEN (pin9) senses the voltage at the transformer secondary. When VSEN reaches 3.0V, the output voltage is regulated. If no current is sensed approximately 1.5 seconds IC501 shunt off.

The current flowing through CCFL is sensed and regulated through sense resistor R509, R511. The feedback voltage through R506, R507, C508 connected to Pin11 (ISEN), then compared with a reference voltage (1.5V) via a current amplifier, resulting in PWM drive outputs to full-bridge switches.

4.2 Protection circuit

Over Voltage Protection: R501 and R502 are connected in high voltage output connector, the divided AC voltage is inverted DC voltage through D508, R505 and C507 are used to rectify wave & dump noise. Then the voltage signal reaches Pin9 VSEN of IC501, when the voltage changes, build-in PWM of IC501 will adjust output voltage.

Open Lamp Protection: In normal operation, the resistors R510, R511, R512, R509 are sensed a high level AC voltage, the AC signal OP1 invert DC voltage through D509, R515, C533, and the high level DC voltage reaches the gate pin of Q502, similarly, the gate pin of Q503, Q504, Q505 has high level DC voltage. So the gate pin of Q501 has a low level voltage, and the IC501 is normal operation. Once one of signal OP1, OP2, OP3, and OP4 is low, the voltages of Q501 gate pin is high level, and make the voltage of ISEN low level, the IC501 will be shunt down.

Chapter 4- Disassembly & Assembly

1. Exploded Diagram

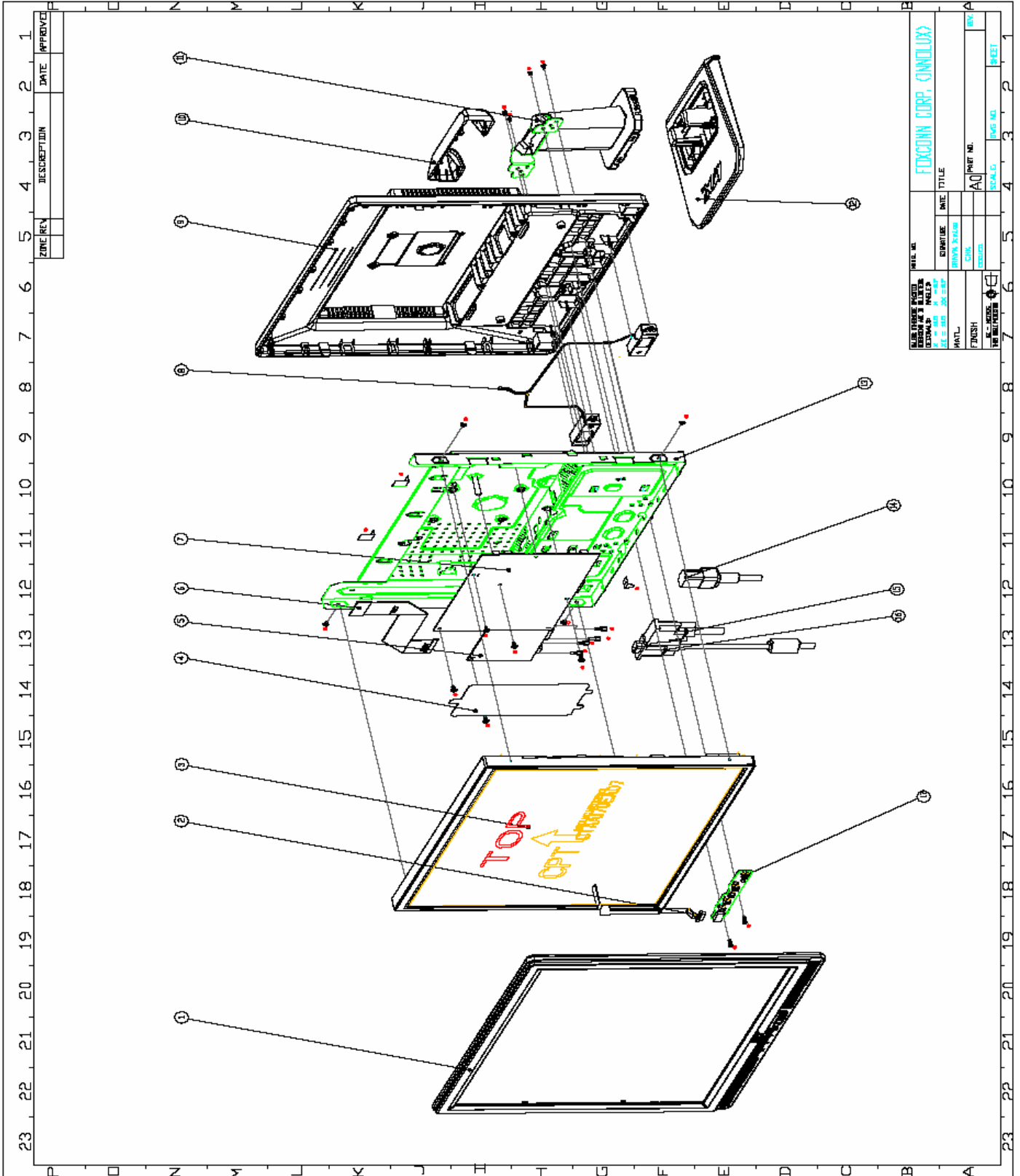

2. Disassembly Block

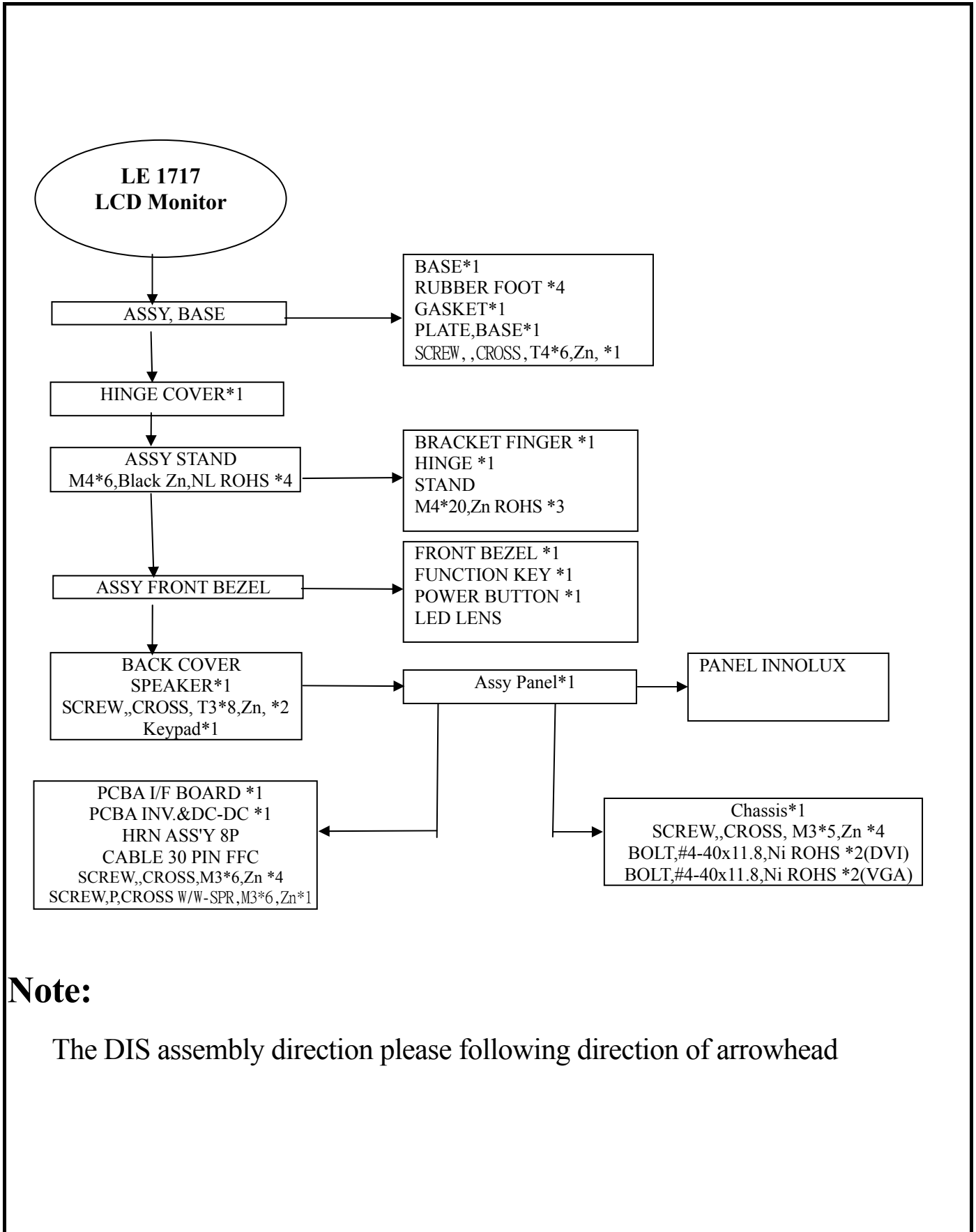

Note:

The DIS assembly direction please following direction of arrowhead

3. Assembly Block

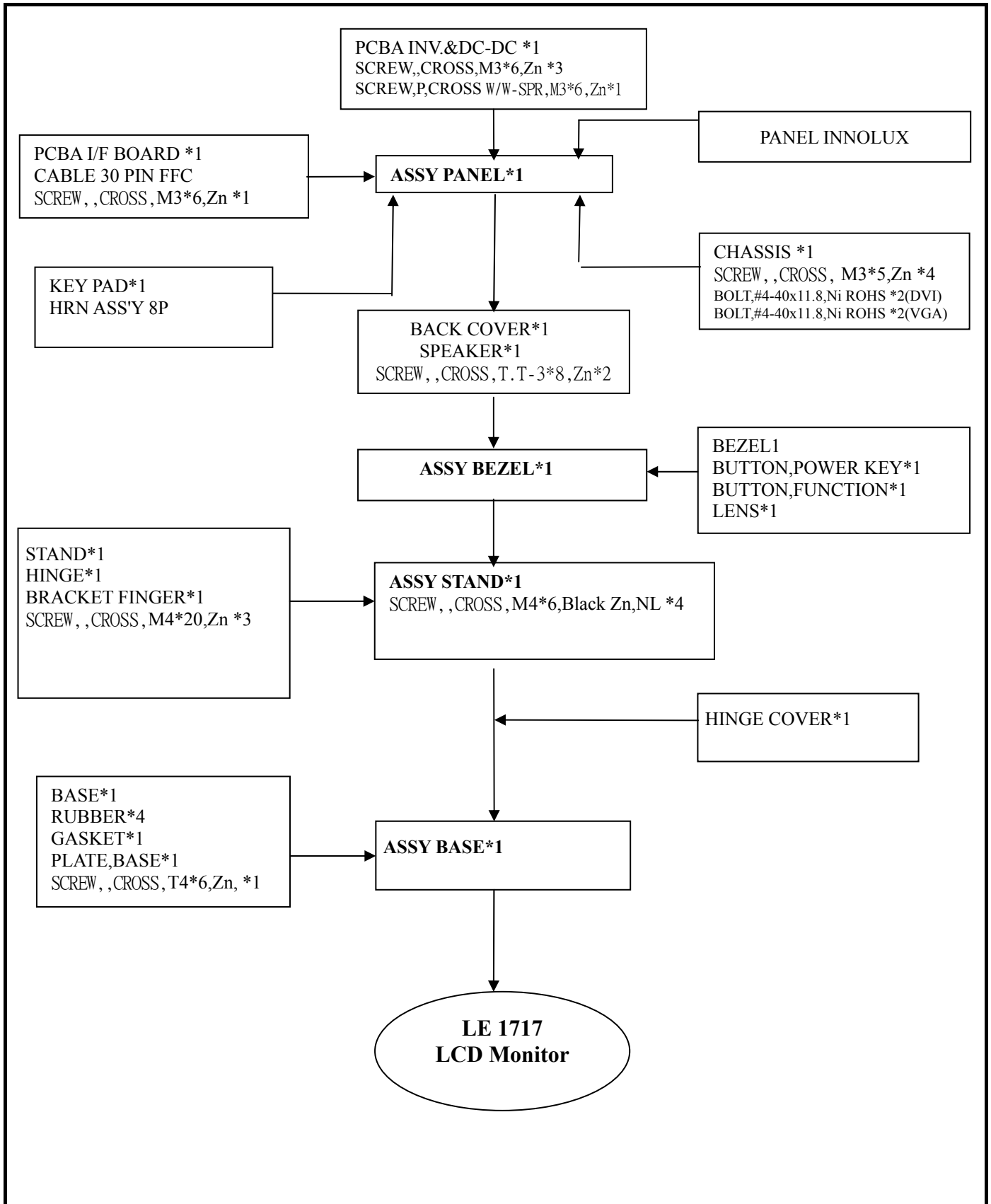

Process To Access Factory Mode

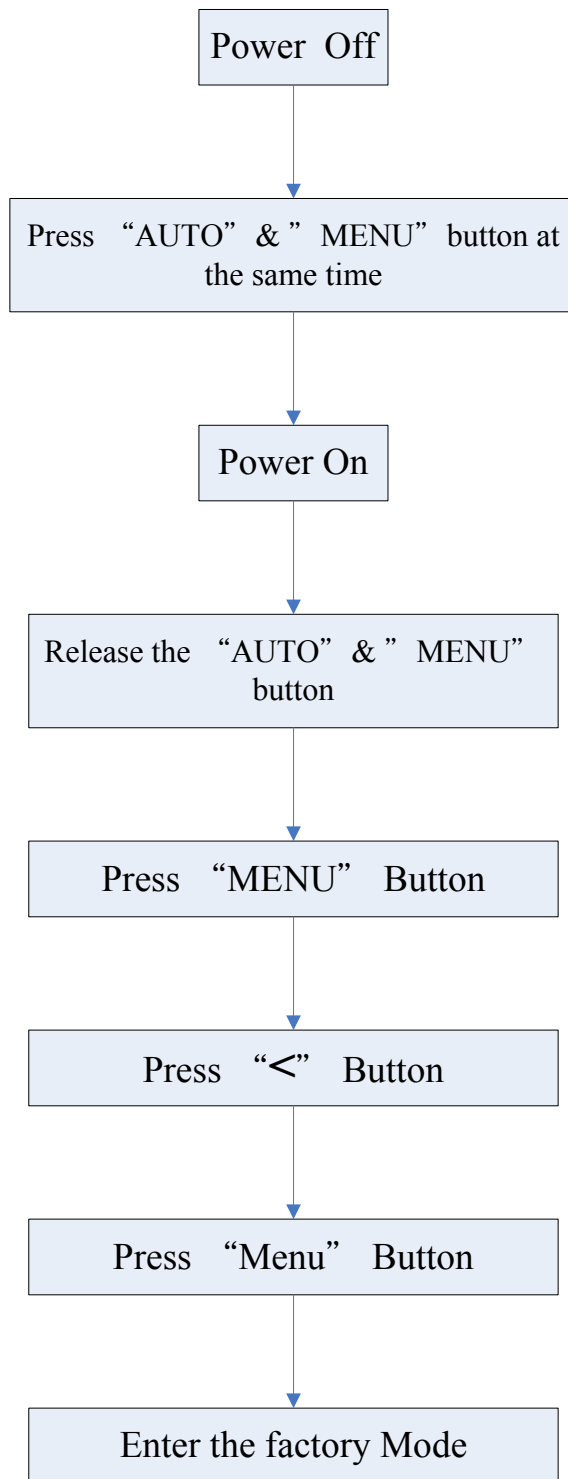

Chapter 5- TEST AND ADJUSTMENT

1. GENERAL POINTS

1.1 Test Equipment or Tool

- 1.1.1 Test pattern generator: PC or video pattern generator (Chroma-2326/2160/2130)
- 1.1.2 Color analyzer: Chroma-7120
- 1.1.3 Power meter: AC Source Chroma-6408
- 1.1.4 Electrical safety tester: Chroma (Zentech) 9032A
- 1.1.5 Stereo source: Music or signal generator input
- 1.1.6 Auto shock fixture
- 1.1.7 Temperature and humidity sensor
- 1.1.8 DDC interface card and EDID file

1.2 Preset Test Pattern

- 1.2.1 Crosshatch (General-1)
- 1.2.2 Gray Bar (16 & 32 levels)
- 1.2.3 Full White
- 1.2.4 Aging (Burn-in) Pattern: Full Red, Green, Blue, White, and Black

1.3 AC input

All measurements mentioned hereafter are carried out at a normal mains voltage (90 - 264 V_{AC} for the model with full range power supply, unless otherwise stated)

1.4 Observation Distance

- 1.4.1 Observation distance from eyes to panel is defined as 50cm
- 1.4.2 Visual distance from instrument to panel is defined as 20cm

1.5 Key Function Description

1.5.1 Control buttons on the front bezel

CONTROL KEY	KEYS FUNCTION
[AUTO]	A. When OSD un-displays, press [AUTO] to perform auto-adjustment B. When OSD displays, press [AUTO] to return to previous level menu
[MENU]	A. When OSD isn't shown on screen, press [MENU] to enter OSD interface B. When OSD displays, press [MENU] to perform function of menu icon that is highlight or enter next level menu
[▶], [◀]	A. When "MENU OSD" displays, press these keys to change the contents of an adjustment item, or change an adjustment value B. When "MENU OSD" un-displays, press [▶], adjust volume high; press [◀] adjust volume low
[POWER]	Power on or power off the monitor

1.5.2 Hot Key Operation

FUNCTION	HOT KEY OPERATION					DESCRIPTION
	AUTO	◀	▶	MENU	POWER	
FACTORY MODE	•			•	ON	Press [AUTO] & [MENU] at the same time, and then press [POWER] for DC power on. OSD menu will be shown with "F" on the left top. Select "F" for entering factory mode.

1.6 Burn-in (Aging) Pattern

- 1.6.1 Burn-in patterns are: full Red, Green, Blue, White and Black
- 1.6.2 Stop burn-in pattern by providing with video signal from D-sub or DVI-D connector
- 1.6.3 Enter or exit burn-in mode by setting “burn-in” to be “on” or “off” in the factory mode

1.7 Warm Up

All test units have to be done warm up after at least 2 hours in a room with temperature of $40\pm 5^{\circ}\text{C}$.
(Except particular requirement)

2. INPUT SIGNAL

2.1 Video Signal Input

2.1.1 VESA Analog

The video input consists of red, green, and blue signals. The video signals are analog levels, where 0V corresponds to black and 700mV is the maximum signal amplitude. Input impedance of video pins is $75\ \text{ohm} \pm 1\%$.

Sync signal input

The capability of sync signal inputs shall include separate sync. Input impedance: 2k2 ohms the signals are defined as follow:

Separate sync TTL level, Positive/Negative

2.1.2 Input signal mode

PRESET TEST MODE TIMING

Resolution	H-Freq. (kHz)	V-Freq. (Hz)	Dot Clock (MHz)	Mode	
640 x 480	31.5	60.0	25.175	VESA IBM-AT Compatible machine PC-9800 series	
	37.9	72.0	31.500		
	37.5	75.0	31.500		
800 x 600	35.1	56.0	36.000		
	37.9	60.0	40.000		
	48.1	72.0	50.000		
	46.9	75.0	49.500		
1024 x 768	48.4	60.0	65.000		
	56.5	70.0	75.000		
	60.0	75.0	78.750		
1280 x 1024	64.0	60.0	108.000		
	80.0	75.0	135.000		
640 x 350	31.5	70.0	25.175		US/IBM Text
720 x 400	31.5	70.0	28.322		
832 x 624	49.7	74.6	57.283		
1024 x 768	60.2	75.0	80.000	Power Macintosh series	
	48.8	60.0	64.000		

2.1.3 VGA signal cable

15 pin D-sub VGA connector of signal cable.

2.1.4 Interface

Analog signal: The input signals are applied to display through D-sub cable.

Length: 1.8 m +/- 50 mm (fixed)

Connector type: D-sub male.

With DDC_2B pin assignments.

Blue connector thumb-operated jack screws

Pin Assignment:

PIN No.	SIGNAL	PIN No.	SIGNAL
1	Red video input	9	VGA +5V
2	Green video input	10	GND
3	Blue video input	11	GND
4	GND	12	Serial data line (SDA)
5	Cable detect	13	H. Sync / H+V
6	Red video GND	14	V. Sync
7	Green video GND	15	Data clock line (SCL)
8	Blue video GND		

3. FUNCTION CHECK

3.1 OSD Function Test

3.1.1 Test mode: 1280x1024 @ 60 Hz

3.1.2 Test pattern: pattern #1 of crosshatch (GENERAL-1)

3.1.3 Check single key function and hot key function about key “Power”, “Menu”, “▶”, “◀”, “Exit/Auto”, it should operate normally

3.2 Screen Picture Check

3.2.1 Test mode: 1280x1024 @ 60 Hz

3.2.2 Test pattern: pattern #1 of crosshatch (GENERAL-1)

3.2.3 Select OSD menu to execute ‘Auto’ function, screen picture shouldn’t appear abnormal phenomenon and picture on screen should fit in with active display screen.

3.3 Auto Color Balance

3.3.1 Test mode: 640x480 @ 60 Hz

3.3.2 Test pattern: pattern #42 of 5-MOSAIC

3.3.3 Enter "Factory Mode" pressing "Auto color" key, and execute "AUTO".

3.4 Timing Check

3.4.1 Test mode: Refer to preset timing table and power saving mode

3.4.2 Test pattern: pattern #1 of crosshatch (GENERAL-1)

3.4.3 After change above timing and execute “Auto” function automatically, picture should fit in with active display screen.

3.4.4 Under power saving mode, LED lamp on the key board should be orange

3.5 Power Consumption Function Test

3.5.1 Test mode: 1280x1024 @ 60 Hz

3.5.2 Test pattern: pattern #41 of “WHITE”

3.5.3 Adjusting both brightness value to maximum,

3.5.4 Measure power consumption as the following

Status	Power Consumption	LED Display
Normal	< 42W(with audio)	Green
Standby (No H/V sync)	< 1W	Orange
Power off	< 1W	No display

3.6 VGA Cable Detect Test

If VGA cable of LCD monitor isn't connected to video pattern generator or PC, "NO SIGNAL" should be shown on screen.

3.7 Hi-Pot test

Test condition:

- a. high voltage 2.3KV(DC)
- b. leakage current 10mA
- c. rising time 1 sec.
- d. test time 3 sec.

3.8 Grounding Test

Test condition:

- a. test current 30A / 2 sec
- b. impedance < 0.1Ω

3.9 Bumping Test

3.9.1 Test mode: 1280x1024 @ 60 Hz;

3.9.2 Test pattern: pattern #1 of crosshatch (GENERAL-1)

3.9.3 To shock LCD monitor lightly at the center of rear cover and edges with 1~2kg/cm² force for three times, no abnormal phenomenon is found on panel screen.

4. DISPLAY CHECK**4.1 Panel Flicker Check**

Connect LCD monitor to PC, set LCD monitor to be timing of 1280x1024@60 Hz, adjust brightness to be default value (brightness at maximum), execute "Auto" function, and then check picture of shut down under windows 98 operating system, or flicker-pattern of pixel on-off. It should be that no flicker be found on panel screen.

4.2 Panel Defect Inspection

4.2.1 Test mode: 1280 x 1024@60Hz

4.2.2 Test pattern: Crosshatch/Full white/Red/Green/Blue/Black/16 color bar/64 gray bars

4.2.3 Display quality must be (according to DIN 13406-2 pixel fault class II)

Defect Type	Specification	Major	Minor
Bright dot defect	THD		•
Dark dot defect	THD		•
Total bright and dark dots	THD		•
Bright Dots – 2 Adjacent B	THD		•
Bright Dots – 3 or more Adjacent	THD		•
Black Dots – 2 Adjacent B	THD		•
Black Dots – 3 or more Adjacent	THD		•
Distance between defect dots	THD		•
Distance between Dark dots	THD		•

Note 1: Dot defect is defined as the defective area is not larger than 50% of the dot area. Bright Dot is defined 5% transmission ND filter.

Note 2: Light Leakage: There shall not be visible light around the customer's bezel after assembly in normal View angle.

Defect Type		Specification Size	Count (N)	Major	Minor
Dot Shape(Particle、Scratch and Bubbles in Display area or on The Polarizer)		Black spots which appear when B/L operating $0.15\text{mm} \leq D \leq 0.5 \text{ mm}$	$N \leq 3$		●
Line Shape (Particles、Scratch、Fiber and Bubbles in display area or on The Polarizer)		$L \leq 0.5\text{mm}$ and $W \leq 0.05 \text{ mm}$	Ignored		●
		$0.5\text{mm} < L \leq 5\text{mm}$ and $0.05\text{mm} < W \leq 0.1\text{mm}$	$N \leq 4$		
		$L > 5\text{mm}$ or $W > 0.1\text{mm}$	$N = 0$		
Display non-uniformity		There should be non-uniformity through 5% transparency of filter or judge by limit sample if necessary.			●
Bezel	Scratch	No harm			●
	Dirt				●
	Wrap				●
	Sunken				●
Label	No label	No			●
	Invert label				●
	Broken				●
	Dirt	Word can be read.			●
	Not clear				●
	Word out of				●
	Mistake	No			●
	Position	Be attached on right position			●
Screw	Not enough	No			●
	Limp	No			●
Connecto	Connection	No bend on pins and damage			●
FPC/FFC	Broken	No			●

5. PICTURE CHECK

5.1 Check brightness uniformity

5.1.1 Test mode: 1280x1024 @ 60 Hz

5.1.2 Test pattern: pattern #41 of "WHITE"

5.1.3 Test tool: Color Analyzer Chroma7120

5.1.4 Set brightness and contrast to be maximum, apply pattern as Fig.3, it should be the following requirement:

$$\frac{\text{Min. luminance of nine points (backlight)}}{\text{Max. luminance of nine points (backlight)}} \geq 75\%$$

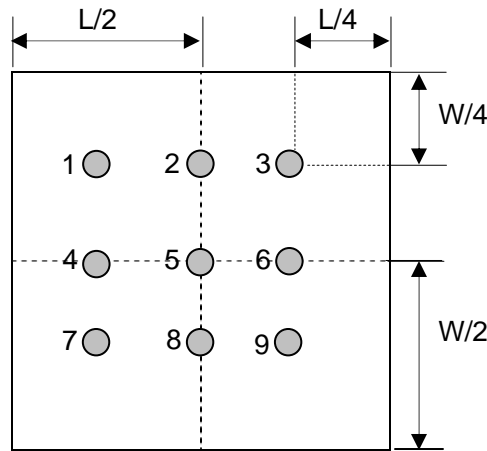

Fig. 3

5.2 Color Temperature Check

5.2.1 Test mode: 1280x1024 @ 60 Hz

5.2.2 Test pattern: pattern #41 of “WHITE”

5.2.3 Test tool: Color Analyzer Chroma7120

5.2.4 Set brightness to be maximum and contrast to be 50%, measure color coordinate and luminance by color analyzer as the following:

Mode	Chromaticity Coordinate	
	x	y
9300K	0.283 ± 0.030	0.298 ± 0.030
USER	/	/
6500K	0.313 ± 0.030	0.329 ± 0.030

5.3 Brightness Out (Video signal input 700mV ± 2%)

5.3.1 Test mode: 1280x1024 @ 60 Hz

5.3.2 Test pattern: pattern #41 of “WHITE”

5.3.3 Test tool: Color Analyzer Chroma7120

Set brightness and contrast to be maximum with white pattern, to measure the screen center, the light output shall be \geq BL cd/m²

Mode	BL (cd/cm ²)	Remark
MT170EN01 V7	300	TYP

5.4 DDC Data Check

5.4.1 EDID program

5.4.2 Execute main program for EDID writing (refer to model type), using scanner for barcode download.

5.4.3 If writing EEPROM is successful, and then shows text "PASS" on screen; if writing EEPROM is failure, then shows text "FAIL".

5.4.4 EDID data: (For example)

For InnoLux MT170EN01_V7 Panel

	0	1	2	3	4	5	6	7	8	9	A	B	C	D	E	F
0	00	FF	FF	FF	FF	FF	FF	00	04	72	46	AD	00	00	00	00
1	01	0F	01	03	08	22	1B	78	E8	DC	55	A3	59	48	9E	24
2	11	50	54	BF	EF	00	01	01	01	01	01	01	01	01	01	01
3	01	01	01	01	01	01	30	2A	00	98	51	00	2A	40	30	70
4	13	00	52	0E	11	00	00	1E	00	00	00	FD	00	38	4B	1E
5	53	0E	00	0A	20	20	20	20	20	20	00	00	00	FF	00	30
6	30	30	30	30	30	30	30	30	30	30	30	0A	00	00	00	FC
7	00	41	4C	31	37	31	37	0A	20	20	20	20	20	20	00	CS

6. AUDIO CHECK

6.1 Audio Sound Check

- 6.1.1.1. Apply audio source of test program, (1)voice "LEFT" and "RIGHT" ;(2)500mVrms sine wave that sweep from 200Hz to 20 KHz, into audio input (light blue), it should be that L speaker sounds while "LEFT" and R speaker sounds while "RIGHT"
- 6.1.1.2. Set the volume control (on OSD) at max (100%). It should be that no buzz or rattling sound occurs over the sweep frequency range.

6.2 Audio control test

- 6.2.1.1 When OSD is not on screen, press key "▶" or "◀", volume adjustment bar appears on screen and value will grow or decrease and sound volume of speakers should be changed.
If the functional test had been passed, adjust volume bar to be at 90% before exit OSD.
After inspection, set the audio control out of OSD.

Chapter 6- TROUBLE SHOOTING

1. No Power & LED Off

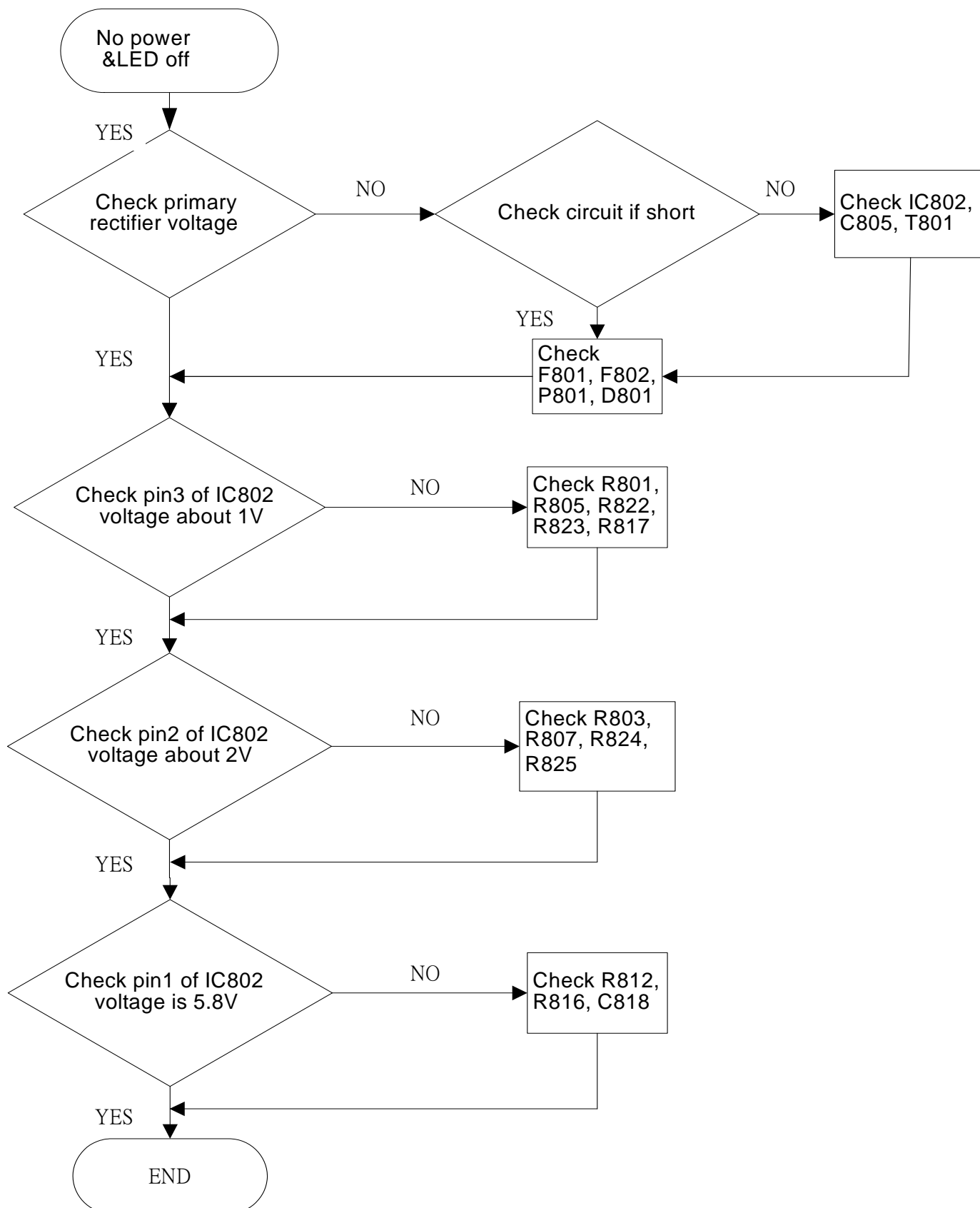

2. Unstable Power

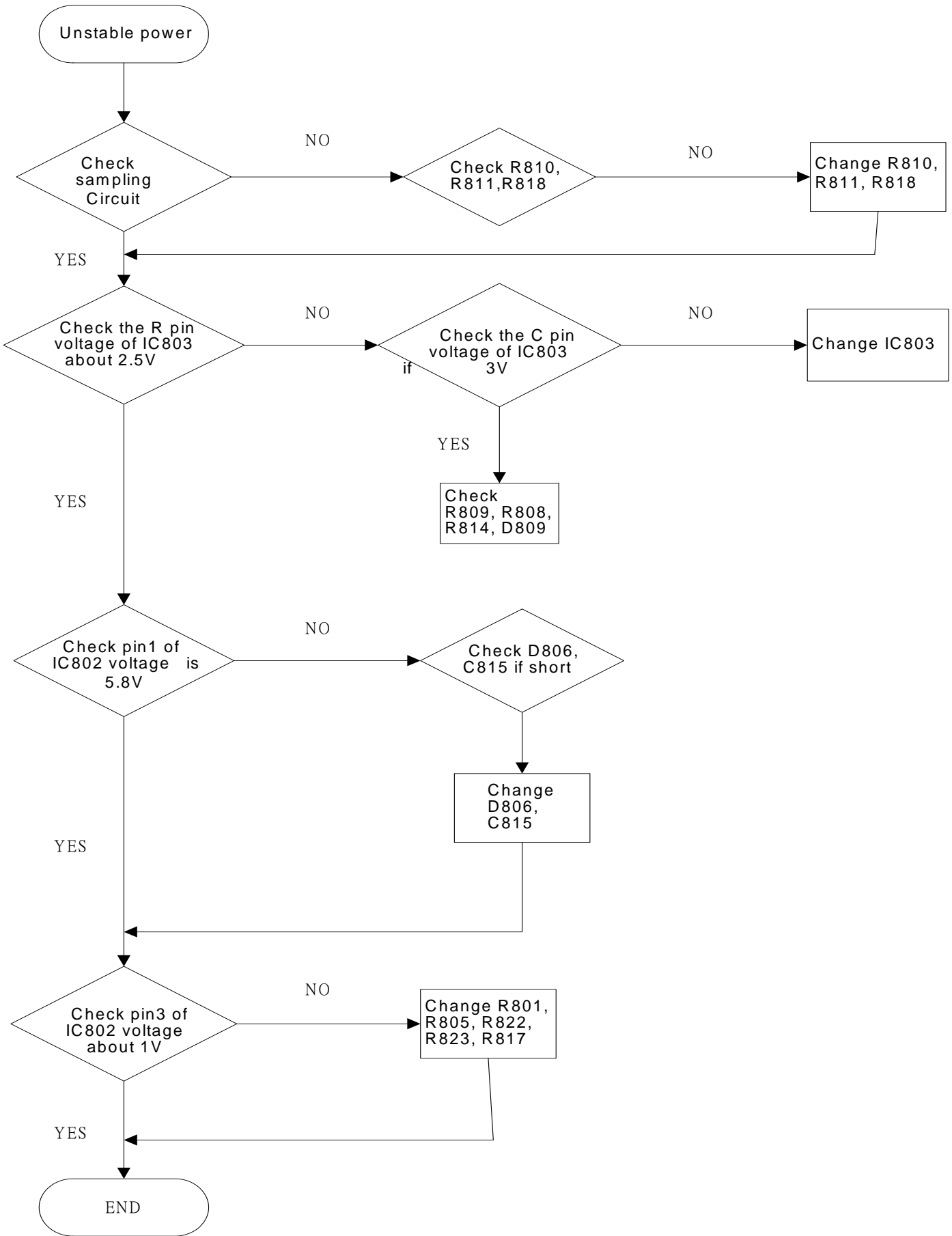

3. No raster

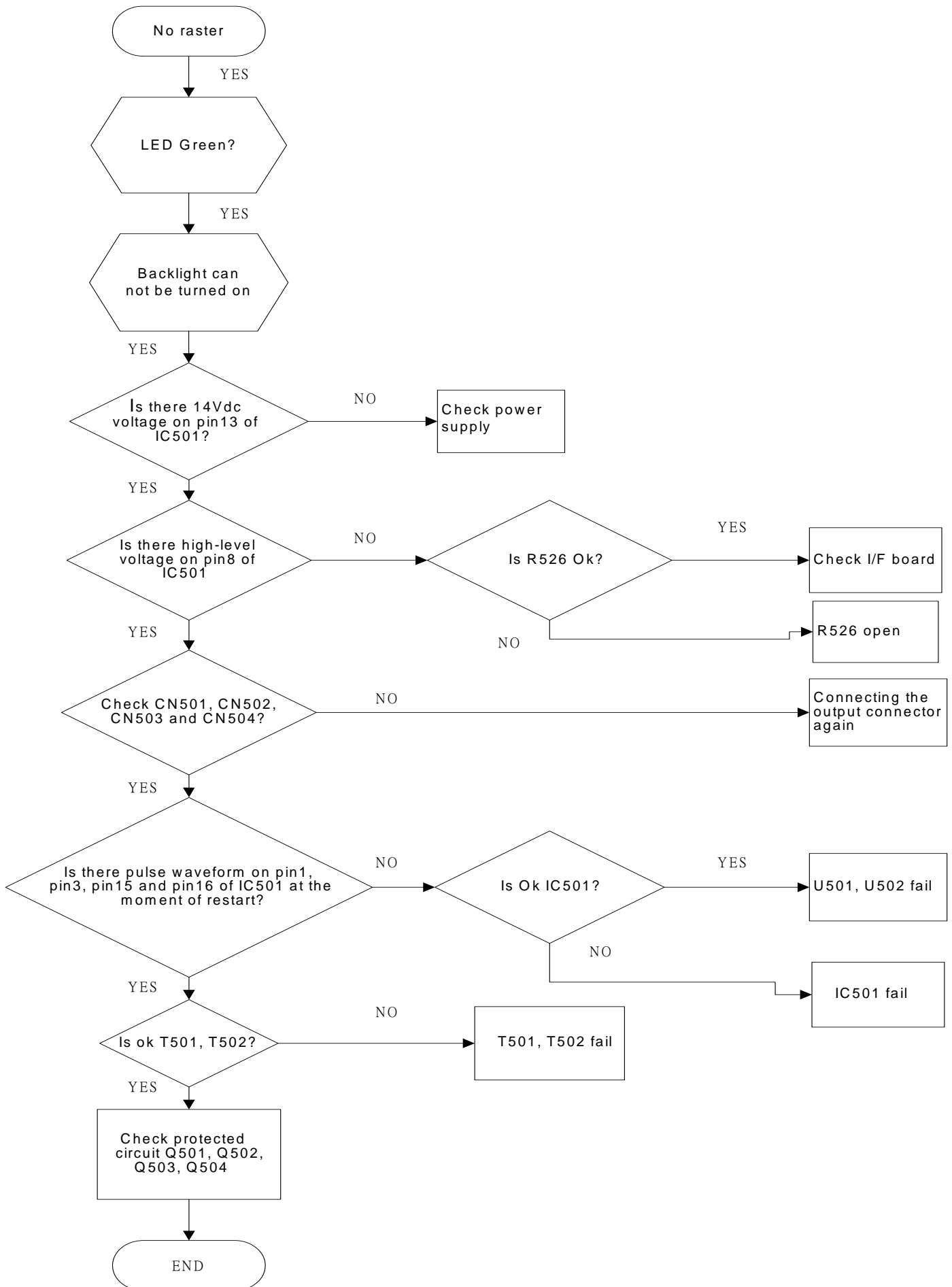

4. Black screen

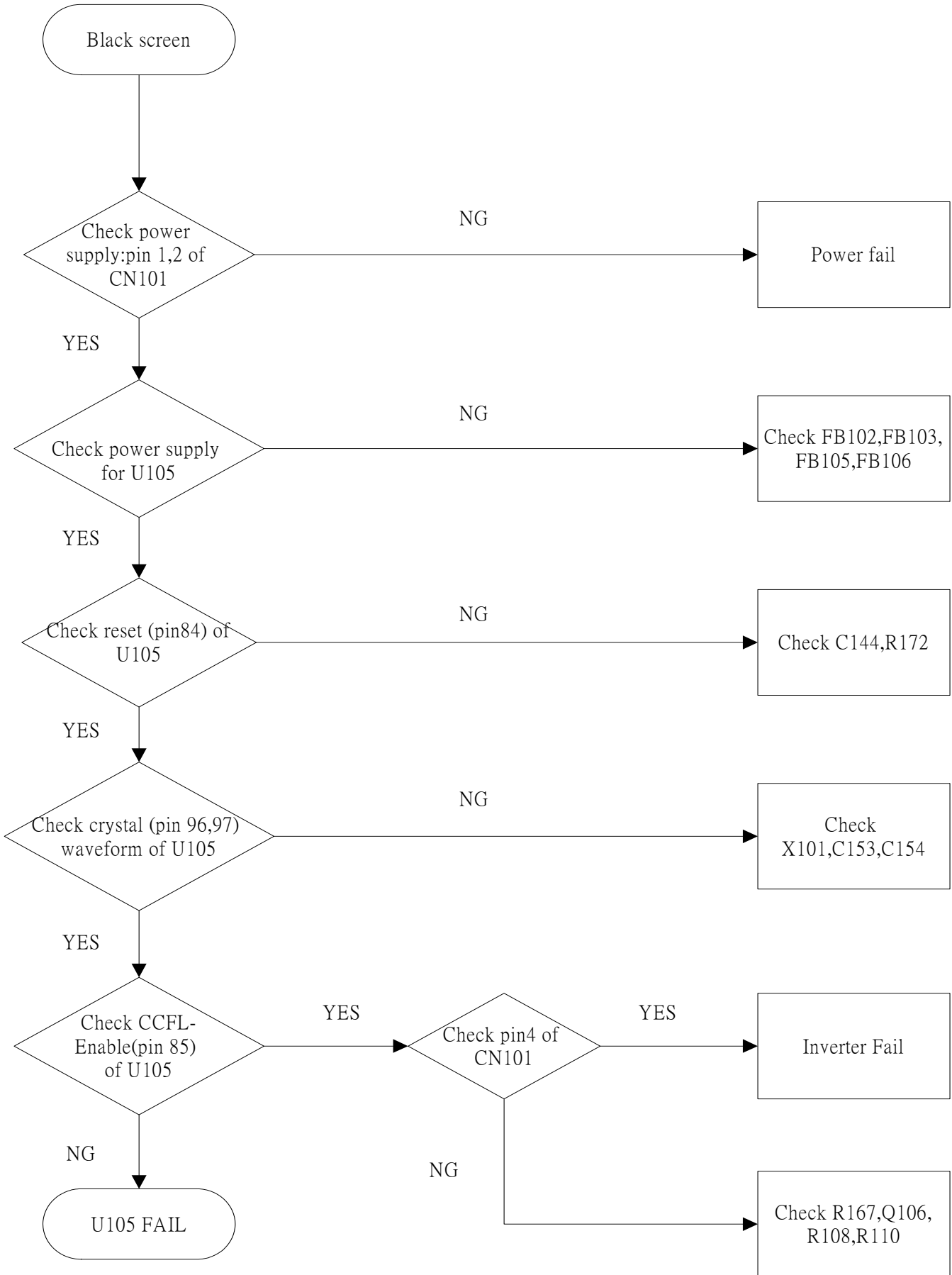

5. Bad Screen

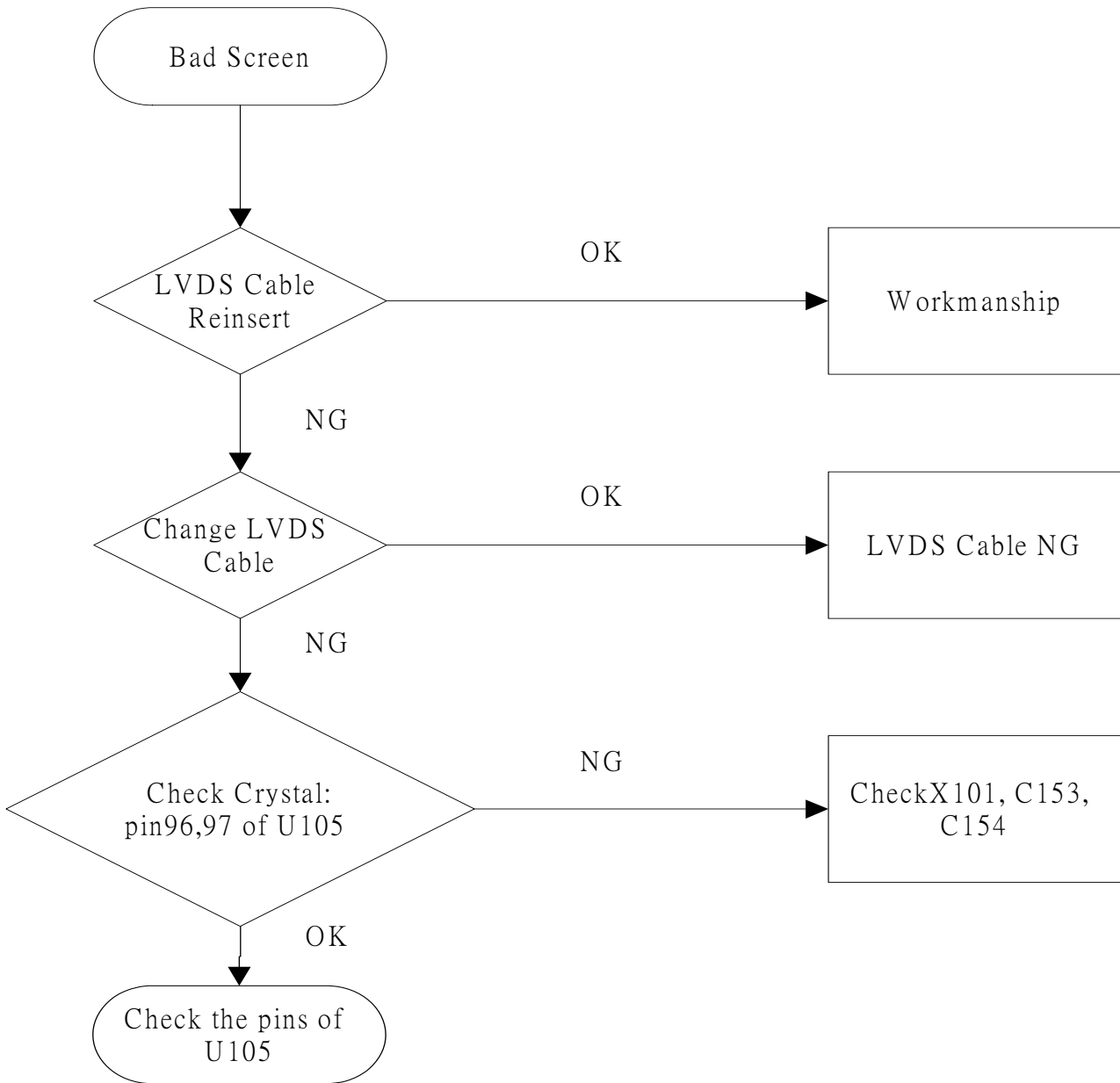

6. White screen

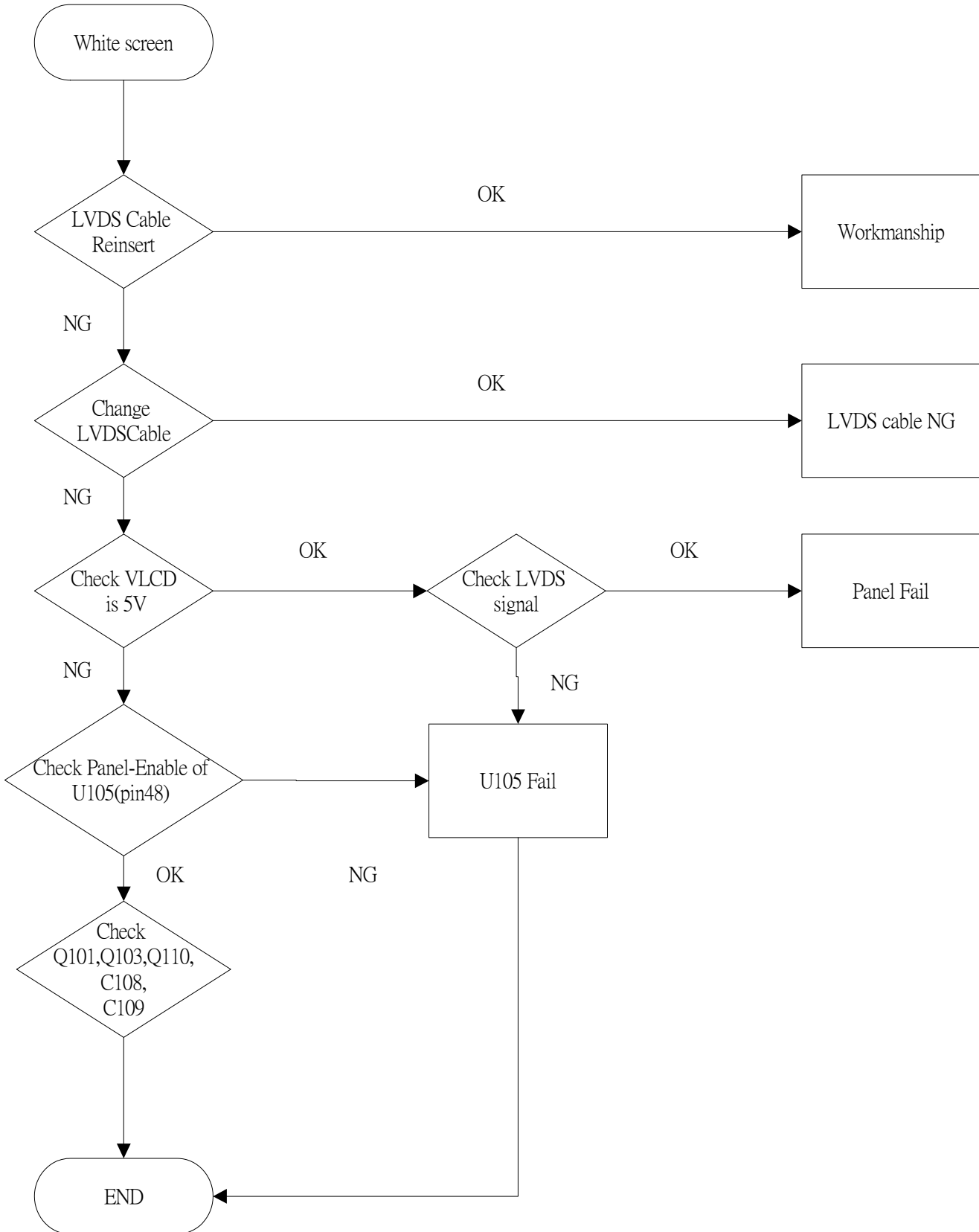

Attachment 1- Bill of Material

PCBA P+I

Item	Component	Component Description	Quantity	Un	Installation Point
10	430637020020R	WFR. 2P P=3.5mm 90°4100-D02 RoHS	4	PC	CN501,CN502,CN503,CN504,
20	410500072270R	XSTR AOP605 N&P-CH PDIP-8(AOS RoHS	0	PC	
20	410500076270R	XSTR AOP604 N&P-CH PDIP-8(AOS) RoHS	0	PC	
20	410500069290R	XSTR AP4501GSD N&P-CH PDIP-8(A DVANCED P	2	PC	U501,U502,
30	426000090490R	XFMR SW 93uH EEL19 DIP SPW-049 RoHS	2	PC	T501,T502,
40	418110058560R	CAP CD SL 10pF 3KV J,ST,RoHS CC45SL3FD10	2	PC	C524,C526,
50	418105058960R	CAP CD SL 5pF 3KV D,ST, RoHS CC45SL3FD05	2	PC	C525,C527,
60	502040604500R	SHIELD,EMI, LE1915 ROHS	1	PC	H501,
70	412140001390R	IC EL817M-B(EVERLIGHT)RoHS	0	PC	
70	412140002380R	IC LTV817M-PR VDE (LITE-ON) P=10mm RoHS	1	PC	IC801,
80	411050007010R	DIO BRDG KBL405G 600V/4A(TSC) RoHS	0	PC	
80	411050006041R	DIO BRDG KBL06M 600V/4A(MOSPEC RoHS	0	PC	
80	411050005020R	DIO BRDG BL4-06-BF52-LF 600V/4A(FRONTIER	1	PC	D801,
90	420431014082R	CAP SEK 100uF/450V M,105°C CF 18x40(2.5)	1	PC	C805,
100	420421020102R	CAP EC 1000uF/10V M,105°C N-F 10x16(L-ES	2	PC	C809,C812,
110	420426810210R	CAP SD 680uF/25V M 105°C F 10x20 RoHS	2	PC	C808,C826,
120	416202223610R	CAP MEY 2200pF 250V M Y2 Y5V P=7.5mm RoH	2	PC	C801,C806,
130	416202224610R	CAP MEY 2200pF 400V M Y,F10mm RoHS	1	PC	C820,
140	416204724610R	CAP MEY 4700pF 400V M Y,F10mm RoHS	1	PC	C824,
150	416194743011R	CAP MEX 0.47uF 275V K X2,F15 RoHS	1	PC	C804,
160	425000010530R	COIL CHK 5uH 7.8X10 CHK-053 0 181085R0L	2	PC	L802,L803,
170	426000050070R	CHOKE L-FILTER 12mH LIN-007 ET-20,RoHS	1	PC	L801,
180	426000090510R	XFMR 750u@1K,+8%,3m,113m,SPW- 051,DIP-1	1	PC	T801,
190	432009400701R	NTC 5Ω 4A 10φ P=5mm, F RoHS	1	PC	RT801,
200	430613420290R	FUSE SLOW 2,250,Axial Lead,3.6 x10mm RoH	1	PC	F801,
210	440149000230R	SKT AC 10A/250V U/C/V,G/Y=45mm TU-301-SP	1	PC	P801,
220	430300800410R	HRN ASS'Y 8P 60mm UL1007#24, RoHS	1	PC	CN801,
230	418247233020R	CAP CD X7R 4700pF 1KV K,W/O FO RMING,RoH	1	PC	C803,
240	735100005400R	ASSY,H/S SRF5-04CT/8-10CT, LE1700 ROHS	1	PC	
250	735100005900R	ASSY,H/S TOP246Y, LE1X09 ROHS	1	PC	
260	412000225020R	IC TDA7496LK DIP-20(UTC)RoHS	0	PC	
260	412000225280R	IC TDA7496L AMPLIFIER(ST)RoHS W/DC VOLUM	1	PC	U701,
270	430631040080R	WFR. 4P 2.0mm R/A HF5604E RoHS	1	PC	CN701,
280	442299001110R	CON,PHONE JACK R/A,1P,CJ363P00 US0PS4,Ro	1	PC	P701,
290	511130000300R	SOLDER WIRE,Sn96.5/Ag3.0/Cu0.5/Ni0.06/Ge	0.003	G	
300	511130001200R	SOLDER BAR,Sn96.5/Ag3.0/Cu0.5/Ni0.06/Ge0	0.0048	G	
310	790571440600R	PCBA,PWR&INV/B,SMD,LE1718 ROHS	1	PC	
10	411090025040R	SCHTKY SRF1045CM 45V/10A ITO22 OAB(MOSPE	0	PC	
10	411090015020R	SCHTKY SRF5-04CT-LF ITO-220AB (FEC) RoHS	0	PC	
10	411090024040R	SCHTKY SRF1040CM 40V/10A ITO22 OAB(MOSPE	1	PC	D805,
20	411090016020R	SCHTKY SRF8-10CT-LF ITO-220AB (FEC) RoHS	0	PC	
20	411090009040R	SCHTKY SRF10100C 100V/10A(MOSP EC)ITO-22	1	PC	D803,
30	507200003800R	HEATSINK,56x20xt10mm LE1904/05	1	PC	
40	509112306100R	SCREW,P,CROSS,T.T-3*6,Zn	2	PC	
10	419342253670R	C SMD(0805) Y5V 2.2uF/25V Z RoHS	2	PC	C502,C511,
20	419311040060R	C SMD(0603) X7R 0.1uF/50V K RoHS	8	PC	C509,C531,C532,C533,C534,C701,C710,C821,
30	419311020060R	C SMD(0603) X7R 1000PF/50V K RoHS	1	PC	C504,
40	419341053670R	C SMD(0805) Y5V 1uF/25V Z RoHS	3	PC	C505,C528,C708,
50	419314720060R	C SMD(0603) X7R 4700PF/50V K RoHS	5	PC	C506,C711,C712,C713,C714,
60	419312220060R	C SMD(0603) X7R 2200PF/50V K RoHS	1	PC	C507,
70	419311030060R	C SMD(0603) X7R 0.01uF/50V K RoHS	1	PC	C508,
80	419316820070R	C SMD(0805) X7R 6800PF/50V K RoHS	2	PC	C523,C530,
90	419301810560R	C SMD(0603) NPO 180PF/50V J RoHS REV:A	1	PC	C529,
100	419314710070R	C SMD(0805) X7R 470PF/50V K RoHS	2	PC	C535,C536,
110	419316830060R	C SMD (0603) X7R 0.068uF 50V,K RoHS	1	PC	C503,
120	414916604310R	RES SMD (0603) 604KΩ F,RT RoHS	1	PC	R539,
130	414916000050R	RES SMD (0603) 0Ω J,RT RoHS	1	PC	R537,
140	414916010350R	RES SMD (0603) 10KΩ J,RT RoHS	4	PC	R532,R533,R534,R535,
150	414916590010R	RES SMD (0603) 590Ω F,RT RoHS	2	PC	R530,R531,
160	414916330410R	RES SMD (0603) 3.3M F RT RoHS	1	PC	R527,
170	414916180310R	RES SMD (0603) 180KΩ F,RT RoHS	2	PC	R523,R526,
180	414916012250R	RES SMD (0603) 1.2KΩ J,RT RoHS	2	PC	R510,R512,
190	414916010410R	RES SMD (0603) 100K F,RT RoHS	2	PC	R508,R524,
200	414916390110R	RES SMD (0603) 3.9KΩ F,RT RoHS	2	PC	R506,R507,
210	414916010550R	RES SMD (0603) 1MΩ J,RT RoHS REV:A	6	PC	R505,R515,R517,R519,R521,R529,
220	414908360110R	RES SMD (0805) 3.6KΩ F,RT RoHS	2	PC	R502,R504,
230	414916487010R	RES SMD (0603) 487Ω F,RT RoHS	2	PC	R509,R511,
240	414916110310R	RES SMD (0603) 110KΩ F,RT RoHS REV:A	1	PC	R522,
250	414904010050R	RES SMD (1206) 10Ω J,RT RoHS	2	PC	R802,R806,
260	414904100010R	RES SMD (1206) 100Ω F,RT RoHS	1	PC	R809,
270	414908010250R	RES SMD (0805) 1KΩ J,RT RoHS REV:A	5	PC	R813,R814,R815,R708,R709,
280	414908010350R	RES SMD (0805) 10KΩ J,RT RoHS REV:A	3	PC	R808,R819,R827,
290	414908120210R	RES SMD (0805) 12K F RT RoHS REV:A	1	PC	R817,
300	414908020150R	RES SMD (0805) 200Ω J,RT RoHS	1	PC	R829,
310	414908330110R	RES SMD (0805) 3.3KΩ F,RT RoHS REV:A	1	PC	R818,
320	414908033550R	RES SMD(0805) 3.3MΩ J,RT,RoHS	4	PC	R801,R805,R822,R823,
330	414908047450R	RES SMD (0805) 470KΩ J,RT RoHS	1	PC	R825,

340	414908510110R	RES SMD (0805) 5.1KΩ F,RT RoHS	1	PC	R810,
350	414916510210R	RES SMD (0603) 51KΩ F,RT RoHS	1	PC	R811,
360	414908051450R	RES SMD (0805) 510KΩ J,RT RoHS	3	PC	R803,R807,R824,
370	414908068950R	RES SMD (0805) 6.8Ω J RT RoHS	2	PC	R812,R816,
380	414916010150R	RES SMD (0603) 100Ω J,RT RoHS REV:A	2	PC	R703,R704,
390	414916015350R	RES SMD (0603) 15KΩ J,RT RoHS	2	PC	R701,R702,
400	414916047250R	RES SMD (0603) 4.7KΩ J,RT RoHS	2	PC	R705,R706,
410	414916100110R	RES SMD (0603) 1KΩ F,RT RoHS REV:A	1	PC	R707,
420	414916047150R	RES SMD (0603) 470Ω J,RT RoHS REV:A	4	PC	R540,R541,R542,R543,
430	410500050130R	XSTR SN7002N N-CH SOT-23(INFINEON),RoHS	0	PC	
430	410500050210R	XSTR 2N7002,N-CH FET SOT-23 (PHILIPS)RoH	5	PC	Q501,Q502,Q503,Q504,Q505,
440	412000354630R	IC OZ9910GN SOP16 (O2 MICRO) RoHS	1	PC	IC501,
450	411020026020R	DIO BAV99-LF 350mW 70V SOT-23 (FEC)RoHS	0	PC	
450	411020026210R	DIO BAV99 350mW 70V SOT-23(PHI RoHS	8	PC	D501,D502,D503,D504,D505,D506,D507,D508,
460	411020046090R	DIO 1N4148W 75V/0.15A(PEC)RoHS SOD-123	0	PC	
460	411020046310R	DIO 1N4148W-F 75V/0.15A(DIODES RoHS,SOD-	0	PC	
460	411023004021R	DIO SN4148-LF 75V/0.15A SMD 1206 (FEC)Ro	5	PC	D509,D510,D511,D512,D515,
470	410500045130R	XSTR MMBT3904 NPN SOT-23(INFIN EON)RoHS	0	PC	
470	410500045140R	XSTR MMBT3904LT1G NPN 200MA 40V SOT23(ON	0	PC	
470	410500045210R	XSTR PMBT3904 NPN 200MA,40V SOT23(PHILIP	1	PC	Q801,
480	411100991920R	ZENER 9.1V MMSZ5239A SOD123(PE C)RoHS	0	PC	
480	411131591952R	ZENER 9.1V 0.5W DDZ9V1C-F,SOD1 23(DIODES	0	PC	
480	411150391950R	ZENER 9.1V MTZS05-9-1-G SOD-123 (MITSUBI	1	PC	ZD801,
490	411100956920R	ZENER 5.6V MMSZ5232A SOD123(PE C)RoHS	0	PC	
490	411131556920R	ZENER 5.6V 0.5W DDZ5V6B-F,SOD1 23(DIODES	0	PC	
490	411150356950R	ZENER 5.6V MTZS05-5.6-G,SOD-12 3(MMC)RoH	1	PC	ZD803,
500	411131516052R	ZENER 16V 0.5W DDZ16-F,SOD123(DIODES)RoH	0	PC	
500	411150316050R	ZENER 16V MTZS05-16-G SOD-123 (MITSUBISH	0	PC	
500	411100916020R	ZENER 16V MMSZ5246A SOD123(PEC RoHS	1	PC	ZD804,
510	790571410600R	PCBA,PWR&INV/B,AI,LE1718 ROHS	1	PC	
10	790571450600R	PCBA,PWR&INV/B,AI/A, LE1718 ROHS	1	PC	
20	790571460600R	PCBA,PWR&INV/B,AI/R, LE1718 ROHS	1	PC	
10	415020330540R	RES CF 1/4W 33Ω J,AT MINI RoHS	2	PC	R536,R538,
20	414870305540R	RES MG HV 1/2Ws 3MΩ 3KV J,AT RoHS	2	PC	R501,R503,
30	415130680540R	RES CF 1/2W 68Ω J,AT RoHS REV:A	1	PC	R804,
40	415340101540R	RES MOF 1W 100Ω J,AT MINI RoHS	1	PC	R828,
50	411032006020R	DIO FR10-10-LF 1000V/1A AT(FRO NTIER)RoH	0	PC	
50	411020055330R	DIO MUR1100ERL AXIAL LEAD(ON) RoHS	1	PC	D804,
60	411030003040R	DIO FR103 200V/1A DO-41(MOSPEC RoHS	0	PC	
60	411020052020R	DIO A02-LF 200V/1A R1(FEC)RoHS	1	PC	D806,
70	411022020090R	DIO P6KE200A 600W/100A,DO-15(P ANJIT)RoH	0	PC	
70	411022020330R	DIO P6KE200ARL 600W/100A AT(ON RoHS	1	PC	ZD802,
80	411022003020R	DIO 1N4148-LF 75V/0.15A AT (FEC)RoHS	0	PC	
80	411022003210R	DIO 1N4148 75V/0.2A AT (PHIL) RoHS	1	PC	D809,
90	506140005700R	LABEL,BARCODE,BLANK,33x7mm, ROHS,FOR PCB	1	PC	
100	432002200160R	BEAD CORE BF30TA-3.5x9x0.8 AT	1	PC	B801,
110	415030105540R	RES CF 1/2W 1MΩ J,AT MINI RoHS	2	PC	R820,R821,
120	430405000000R	JMPR ROLL/KG D=0.6mm,AT,RoHS 7.5MM	520	mm	J501,J502,J511,J512,J516,J701,J702,J803,J805,J806,
130	430405000000R	JMPR ROLL/KG D=0.6mm,AT,RoHS 10MM	312	mm	J503,J506,J703,J804,J807,J808,
140	430405000000R	JMPR ROLL/KG D=0.6mm,AT,RoHS 12.5MM	364	mm	J505,J507,J508,J509,J510,J514,J515,
150	430405000000R	JMPR ROLL/KG D=0.6mm,AT,RoHS 15MM	156	mm	J513,J801,J802,
160	430405000000R	JMPR ROLL/KG D=0.6mm,AT,RoHS 20MM	52	mm	J504,
170	490571400100R	PCB,PWR&INV./B, LE1718-XE0 ROHS	1	PC	
10	420424710260R	CAP SD 470uF/25V M 105°C ST 10x16,RoHS	3	PC	C522,C702,C810,
20	418210227030R	CAP CD X7R 1000pF 500V K VT RoHS	2	PC	C802,C811,
30	418310413630R	CAP CD Y5V 0.1uF 50V Z,VT RoHS	2	PC	C817,C822,
40	416231041530R	CAP MEB 0.1uF 100V J,(RSB),VT RSBEC3100D	1	PC	C816,
50	418147038530R	CAP CD NPO 47pF 1KV J,VT RoHS	1	PC	C813,
60	420264700230R	CAP SH 47uF 25V M,125°C,VT, 6.3x11,RoHS	4	PC	C814,C815,C818,C819,
70	410072013150R	XSTR UTC2SC1815L-GR NPN TO92 (UTC)RoHS	0	PC	
70	410072013210R	XSTR 2PC1815GR*1 VT (PHILIPS) RoHS REV:	0	PC	
70	410072013370R	XSTR 2SC1815-GR (T2SPF.T) VT (TOSHIBA)Ro	1	PC	Q802,
80	412022002240R	IC KA431AZ 1%,VT (FAIRCHILD) RoHS	0	PC	
80	412022002300R	IC AP431VL TO-92 1% VT (ATC) RoHS	0	PC	
80	412022002840R	IC TLV431ALP TO-92 1%,VT (ON) RoHS	1	PC	IC803,
90	420434710431R	CAP EC 470uF 16V M,105°C VT 8x12,RoHS	3	PC	C704,C705,C709,

PCBA IF

Item	Component	Rev	Component Description	Quantity	Un	Installation Point
10	79057132060 1R		PCBA,IF BOARD(EMEA),OTHR,LE1718-6E0	1	PC	
20	79057134060 1R		PCBA,IF BOARD(EMEA),SMD,LE1718 -6	1	PC	
30	62903000530 1R		PROGRAM(EMEA),LE1718-6E0 ROHS	1	PC	
10	43063108007 OR	A	WFR 2.0mm 8P 180°4500-08 RoHS	1	PC	CN101,
20	44081901503 OR	A	CON,D-SUB,FEM.15P RA W/O SCREW DZ11AA1-H	1	PC	CN103,
30	43063108013 A		WAFER 2x4P 2.0mm,200PHD-2*4ST RoHS	1	PC	CN105,

40	OR 42043101046 1R	A	CAP EC 100uF 16V M,105°C ST 5x11(SK) RoH	3	PC	C101,C102,C108,
50	OR 42043220046	A	CAP EC 22uF 16V M,105°C ST, 5x11,RoHS	5	PC	C130,C133,C142,C145,C105,
60	OR 42043100026	A	CAP EC 10uF 25V M,105°C ST 5x11 RoHS	2	PC	C111,C144,
70	OR 43200801027	A	XTAL 14.31818MHz HC-49US DIP 16pF 30PPM	1	PC	X101,
10	OR 41050004427	A	XSTR AO3401L P-CH(ALPHA-OMEGA) SOT23 RoH	0	PC	
10	OR 41050006829	A	XSTR AP2305GN P-CH SOT23(APEC) RoHS	1	PC	Q101,
20	OR 41050004513	A	XSTR MMBT3904 NPN SOT-23(INFIN EON)RoHS	0	PC	
20	OR 41050004514	A	XSTR MMBT3904LT1G NPN 200MA 40V SOT23(ON	0	PC	
20	OR 41050004521	A	XSTR PMBT3904 NPN 200MA,40V SOT23(PHILIP	3	PC	Q106,Q103,Q111,
30	OR 41050004618	A	XSTR MMBT3906LT1G PNP 200mA 40V SOT23(ON	0	PC	
30	OR 41050004613	A	XSTR MMBT3906 PNP SOT-23(INFIN EON)RoHS	0	PC	
30	OR 41050004621	A	XSTR PMBT3906 PNP 200MA,40V SOT23(PHILIP	2	PC	Q102,Q105,
40	OR 41050005013	A	XSTR SN7002N N-CH SOT-23(INFINEON),RoHS	0	PC	
40	OR 41050005021	A	XSTR 2N7002,N-CH FET SOT-23 (PHILIPS)RoH	1	PC	Q110,
50	OR 41102002602	A	DIO BAV99-LF 350mW 70V SOT-23 (FEC)RoHS	0	PC	
50	OR 41102002639	A	DIO BAV99,SOT-23(INFINEON)RoHS	0	PC	
50	OR 41102002621	A	DIO BAV99 350mW 70V SOT-23(PHI RoHS	4	PC	TVS101,TVS102,TVS103,TVS104,
60	OR 41102004702	A	DIO BAV70-LF 70V SOT23 (FEC) RoHS	0	PC	
60	OR 41102004721	A	DIO BAV70 85V SOT23 (PHILIPS) RoHS	1	PC	D103,
70	OR 41109000531 1R	A	SCHTKY B240A 40V/2A SMA(DIODES RoHS	0	PC	
70	OR 41109002041	A	SCHTKY SKS20-04AT-G 40V/2A THIN SMA (MMC	1	PC	D101,
80	OR 41110115695	A	ZENER BZV55-C5V6 SOD80C(PHILIP S) RoHS	0	PC	
80	OR 41115035695	A	ZENER 5.6V MTZS05-5.6-G,SOD-12 3(MMC)RoH	0	PC	
80	OR 41110065695 1R	A	ZENER 5.6V ZMM5232B-LF DO213AA (FRONTIER	5	PC	ZD101,ZD105,ZD106,ZD107,ZD108,
90	OR 41200037202	A	IC LD1117AL-3.3V-A SOT-223(UTC RoHS	0	PC	
90	OR 41200037283	A	IC AS1117L-3.3TR-LF,SOT223(A1S EMD)RoHS	1	PC	U101,
100	OR 41200033002	A	IC LD1117AL-1.8V-A SOT223(UTC) RoHS	0	PC	
100	OR 41200033083	A	IC AS1117L-1.8/TR-LF,SOT223(A1 SEMI)RoHS	1	PC	U102,
110	OR 41200036199	A	IC CAT24WC02W-TE13 SOIC-8 RoHS (CATALYST	0	PC	
110	OR 41200001028	A	IC M24C02-WMN6TP SO8 2K (ST) RoHS	0	PC	
110	OR 41200043548	A	IC AT24C02BN-10SU-1.8 SOIC8 2K (ATMEL)Ro	1	PC	U103,
120	OR 41200043619	A	IC TSUM16AL-LF PQFP100(MSTAR)R oHS	1	PC	U105,
130	OR 41200035831	A	IC PM25LV010-25SCE SOIC8(PMC) RoHS	1	PC	U106,
140	OR 41200027928	A	IC M24C04-WMN6TP4K SOP8 (ST) RoHS	0	PC	
140	OR 41200027999	A	IC CAT24WC04W-TE13 (CATALYST) RoHS	0	PC	
140	OR 41200027948	A	IC AT24C04N-10SU-2.7 SOP8 4K(A TMEL)RoHS	1	PC	U108,
150	OR 41491600005	A	RES SMD (0603) 0Ω J,RT RoHS	3	PC	R112,R115,R118,
160	OR 41491675091	A	RES SMD (0603) 75Ω F,RT RoHS REV:A	3	PC	R133,R134,R135,
170	OR 41491601015	A	RES SMD (0603) 100Ω J,RT RoHS REV:A	22	PC	R113,R116,R119,R130,R129,R114,R117,R120,R124,R125,R127,R131,R132,R162,R163,R167,R168,R166,R17 8,R179,R188,R189,
180	OR 41491639001	A	RES SMD (0603) 390Ω F,RT RoHS	3	PC	R101,R107,R169,
190	OR 41491604715	A	RES SMD (0603) 470Ω J,RT RoHS REV:A	1	PC	R121,
200	OR 41491602225	A	RES SMD (0603) 2.2KΩ J,RT RoHS	2	PC	R136,R137,

210	OR 41491604725	A	RES SMD (0603) 4.7KΩ J,RT RoHS	22	PC	R108,R110,R122,R140,R141,R143,R145,R147,R149,R150,R154,R155,R156,R173,R174,R175,R177,R180,R181,R182,R183,R185,
220	OR 41491601035	A	RES SMD (0603) 10KΩ J,RT RoHS	4	PC	R106,R142,R144,R172,
230	OR 41491602035	A	RES SMD (0603) 20KΩ J,RT RoHS REV:A	1	PC	R105,
240	OR 41491601045	A	RES SMD (0603) 100KΩ J,RT REV:A RoHS	1	PC	R102,
250	OR 41575472508	A	RP(0612)4.7KΩx4 1/16W J 8P4R RoHS REV:A	1	PC	RP102,
260	OR 41491600005	A	RES SMD (0603) 0Ω J,RT RoHS	2	PC	R170,R171,
270	OR 41491605105	A	RES SMD (0603) 51Ω J,RT,RoHS REV:A	1	PC	R195,
280	OR 41491601025	A	RES SMD (0603) 1KΩ J,RT RoHS REV:A	5	PC	R157,R158,R159,R160,R161,
290	OR 41930101056	A	C SMD(0603) NPO 100PF/50V J RoHS	7	PC	C158,C159,C160,C161,C162,C163,C164,
300	OR 41930220056	A	C SMD(0603) NPO 22PF/50V J RoHS	2	PC	C153,C154,
310	OR 41930330056	A	C SMD(0603) NPO 33PF/50V J RoHS	1	PC	C125,
320	OR 41930221056	A	C SMD(0603) NPO 220PF/50V J RoHS	1	PC	C126,
330	OR 41931473006	A	C SMD (0603) X7R 0.047uF 50V,K RoHS	7	PC	C112,C113,C114,C115,C116,C117,C118,
340	OR 41931104006	A	C SMD(0603) X7R 0.1uF/50V K RoHS	22	PC	C103,C104,C106,C107,C109,C129,C156,C131,C132,C134,C135,C136,C137,C139,C141,C143,C147,C148,C149,C150,C151,C152,
350	OR 41934105467	A	C SMD(0805) Y5V 1uF/16V Z RoHS REV:A	2	PC	C140,C181,
360	2R 43200236001	A	BEAD CORE SMD(0805)60Ω 800mA GBK201209T	4	PC	FB102,FB103,FB105,FB106,
370	1R 43200231211	A	BEAD CORE SMD(0805)120Ω 300mA RoHS	1	PC	FB101,
380	OR 44409903003	A	CON, SMD 1.0mm 30PIN RoHS AL2309-A0G1Z	1	PC	CN104,
390	OR 49057130010		PCB,INTERFACE, LE1718-XE0 ROHS	1	PC	

PCBA KEY PAD

Item	Component	Component Description	Quantity	Un	Installation Point
1	411070054990R	LED G/Y § 3x5mm L-115VCGKSYKW-L 5.33-SZ(K	0	PC	
1	411070053990R	LED G/Y § 3x5mm 1259-7SYGUYW/S5 30-A3/F14	1	PC	LED101,
2	430602980120R	SW TACT 160gf 1P,H=4.3mm,DIP SFKHHAL2420	5	PC	SW101,SW102,SW103,SW104,SW105,
3	430631080030R	WFR 2.0mm 8P R/A HF5608E RoHS	1	PC	CN107,
4	490571500100R	PCB,KEY PAD, LE1718	1	PC	

Lev	Phant.item	Item	Component no.	RevLev	Object description	Quantity	Un
.1		0010	506431000300R	A	FILM,PE 500mmx900M ROHS	0.190	ROL
.1		0020	506380001000R	A	TAPE,WRAPPING TYPE,ACER LOGO 50000x72mm,	1.560	ROL
.1		0030	506040007200R	A	CUSHION,EPS-L, LE1718 ROHS	100	PC
.1		0040	506040007210R	A	CUSHION,EPS-R, LE1718 ROHS	100	PC
.1		0050	506020009100R	A	CARTON,ACER, LE1718	100	PC
.1		0060	506150004900R	A	PALLET,L1060xW1060xH120mm,LE1922	1.250	PC
.1		0070	506431001200R	A	FILM,PE 1335x1120xT0.1mm	1.250	PC
.1		0080	506039004800R	A	CORNER PAPER,1770x50x50xT5mm,LE1909 ROHS	5	PC
.1		0090	506039005000R	A	CORNER PAPER,870x50x50xT5mm,ROHS LE1918	5	PC
.1		0100	506120000200R	B	BAG,PE AS 480x590xT0.05(PRINTED),ROHS LE	100	PC
.1		0110	506120002510R	A	BAG,PLASTIC,W220xL280xT0.05mm,CYCLE PRIN	100	PC
.1	x	0120	714075160110R	A	ASSY,FINAL(S,V4/G3),W/SPK,LE1718-6E0(EME	100	PC
..2		0010	618100101100R	A	SPEAKER 1.5W 16Ω 250mm,R/B,W/CASE,X3516	100	PC
..2	x	0020	714085160110R	A	ASSY,PANEL(V4/G3),W/SPK,LE1718-6E0(EMEA/	100	PC
...3		0010	430303000360R	A	HRN LVDS FFC 30P 214mm,RoHS,ACCP30214KU2	100	PC
...3		0020	790571300601R	2A	PCBA,IF/BOARD(EMEA),LE1718-6E0 ROHS	100	PC
...3		0030	790571400600R	2A	PCBA,PWR&INV/B, LE1718 ROHS	100	PC

...3	0040	79057150000R	2A	PCBA,KEYPAD BOARD, LE1718 ROHS	100	PC
...3	0050	631102071170R	A	LCD PANEL 17" MT170EN01-V4-G3,AM17000054	100	PC
...3	0060	509146306100R	A	SCREW,P,CROSS W/WAS,M3*6,Zn ROHS	500	PC
...3	0070	509000000700R	A	BOLT,#4-40x11.8,Ni FOR D-SUB/DVI CONN.RO	200	PC
...3	0080	509146305300R	A	SCREW,PW,CROSS,W/WAS,M3*5,NI	400	PC
...3	0090	509112308100R	A	SCREW,P,CROSS,T.T-3*8,Zn ROHS REV:A	200	PC
...3	0100	502090302710R	A	CHASSIS,W/O DVI, LE1718 ROHS	100	PC
...3	0110	505040202800R	A	INSULATOR,MYLAR,L150xW72xTO.4mm, LE1718	100	PC
...3	0120	509116606510R	A	SCREW,P,CROSS,M4*6,BLACK,NL ROHS (NYLOK)	400	PC
...3	0130	430300800380R	B	HRN ASS'Y 8P 160mm UL2651#28,RoHS	100	PC
...3	0140	505040503000R	A	INSULATOR,PP,15x9x6.5X0.3mm,GLUE(3M), LE	100	PC
...3	0150	505040503100R	A	INSULATOR,PP,22x20x12X0.3mm,GLUE(3M), LE	200	PC
..2	0030	714010004900R	A	ASSY,STAND, LE1718 ROHS	100	PC
...3	0010	501260200500R	A	STAND, LE1710	100	PC
...3	0020	502060001700R	A	HINGE, LE1718 ROHS	100	PC
...3	0030	509446620101R	A	SCREW,B,CROSS,W/W-SPR,M4*20,Zn ROHS	300	PC
...3	0040	502020101600R	A	BRACKET,FINGER, LE1710 ROHS	100	PC
..2	0040	501020206800R	A	COVER,HINGE, LE1718 ROHS	100	PC
..2	0050	714020004900R	A	ASSY,BASE, LE1718 ROHS	100	PC
...3	0010	501240202800R	A	BASE, LE1718	100	PC
...3	0020	502170101300R	A	PLATE,BASE, LE1718 ROHS	100	PC
...3	0030	503020002700R	A	RUBBER,FOOT,L14.8*W9.6*T3.5mm,ROHS LE171	400	PC
...3	0040	503060004000R	A	GASKET,EMI,W11xH8xL15mm(TWO-SIDED ADHESI	100	PC
...3	0050	509112606100R	A	SCREW,P,CROSS,T.T-4*6,Zn	100	PC
..2	0060	714030004900R	A	ASSY,BEZEL, LE1718 ROHS	100	PC
...3	0010	501010204900R	A	BEZEL,FRONT, LE1718 ROHS	100	PC
...3	0020	501030202600R	A	BUTTON,POWER KEY, LE1918 ROHS	100	PC
...3	0030	501030202500R	A	BUTTON,FUNCTION KEY, LE1918 ROHS	100	PC
...3	0040	501120102000R	A	LENS, LE1918 ROHS	100	PC
..2	0070	501020206710R	A	COVER,BACK,W/O DVI, LE1718 ROHS	100	PC
.1	0130	453070800210R	A	PWR CORD 16A/250V BLK 6FT VDE,H05VV-F 3G	100	PC
.1	0140	453010100150R	A	CABLE,D-SUB 15P MALE 6FT BLACK,SZ4120955	100	PC
.1	0150	453030300120R	A	CABLE,AUDIO 1P 6FT BLACK/GREEN CP03B06P0	100	PC
.1	0160	506038002900R	A	CARDBOARD,L1050xW1050xT7mm, LE1922	1.250	PC
.1	0170	506431001000R	B	FILM,PROTECTION,PRINTED(E),LE1701	100	PC

Attachment 2- Schematic

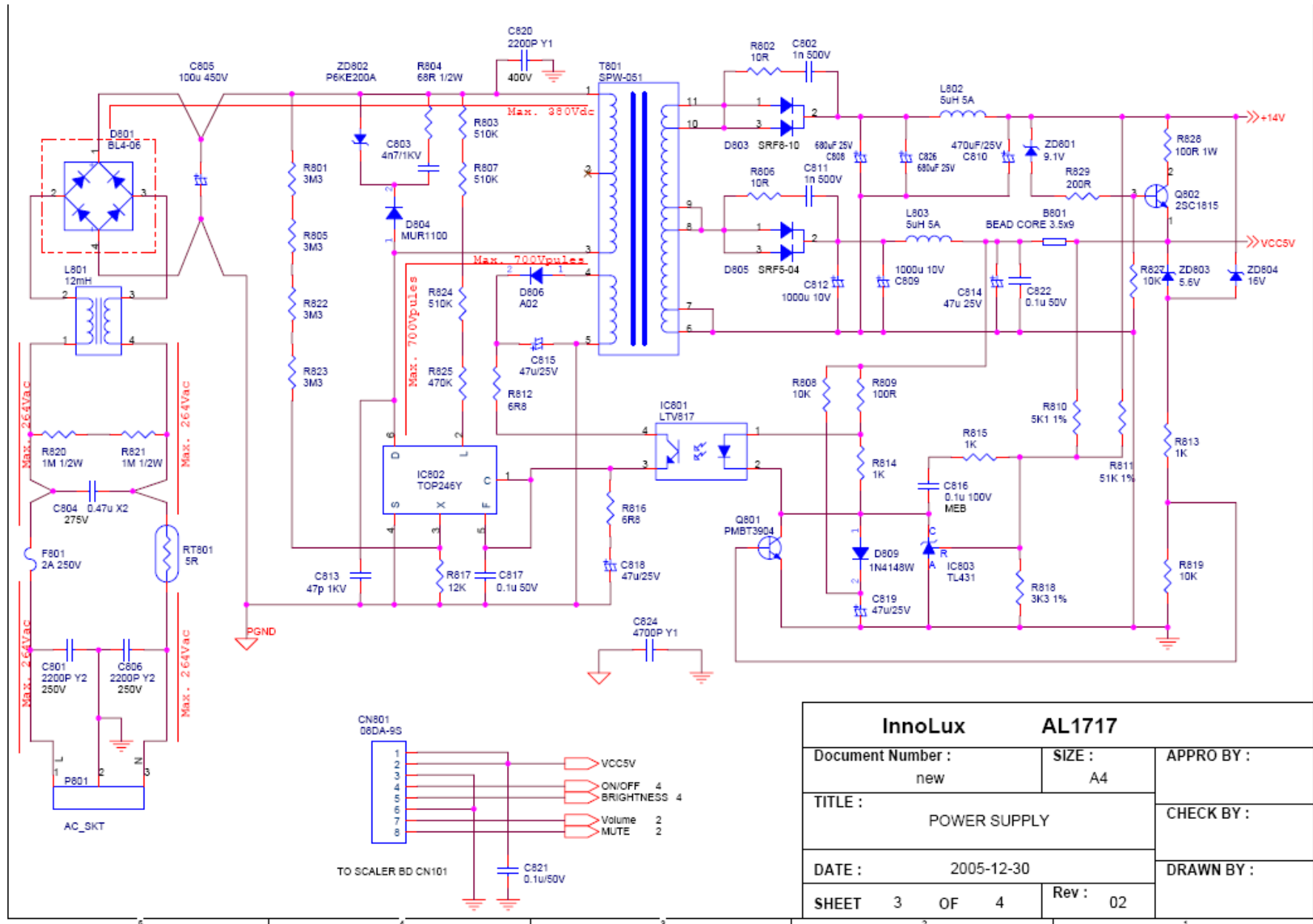

InnoLux		AL1717	
Document Number :	new	SIZE :	A4
TITLE :		POWER SUPPLY	
DATE :	2005-12-30	APPRO BY :	
SHEET 3 OF 4		CHECK BY :	
		DRAWN BY :	
		Rev :	02

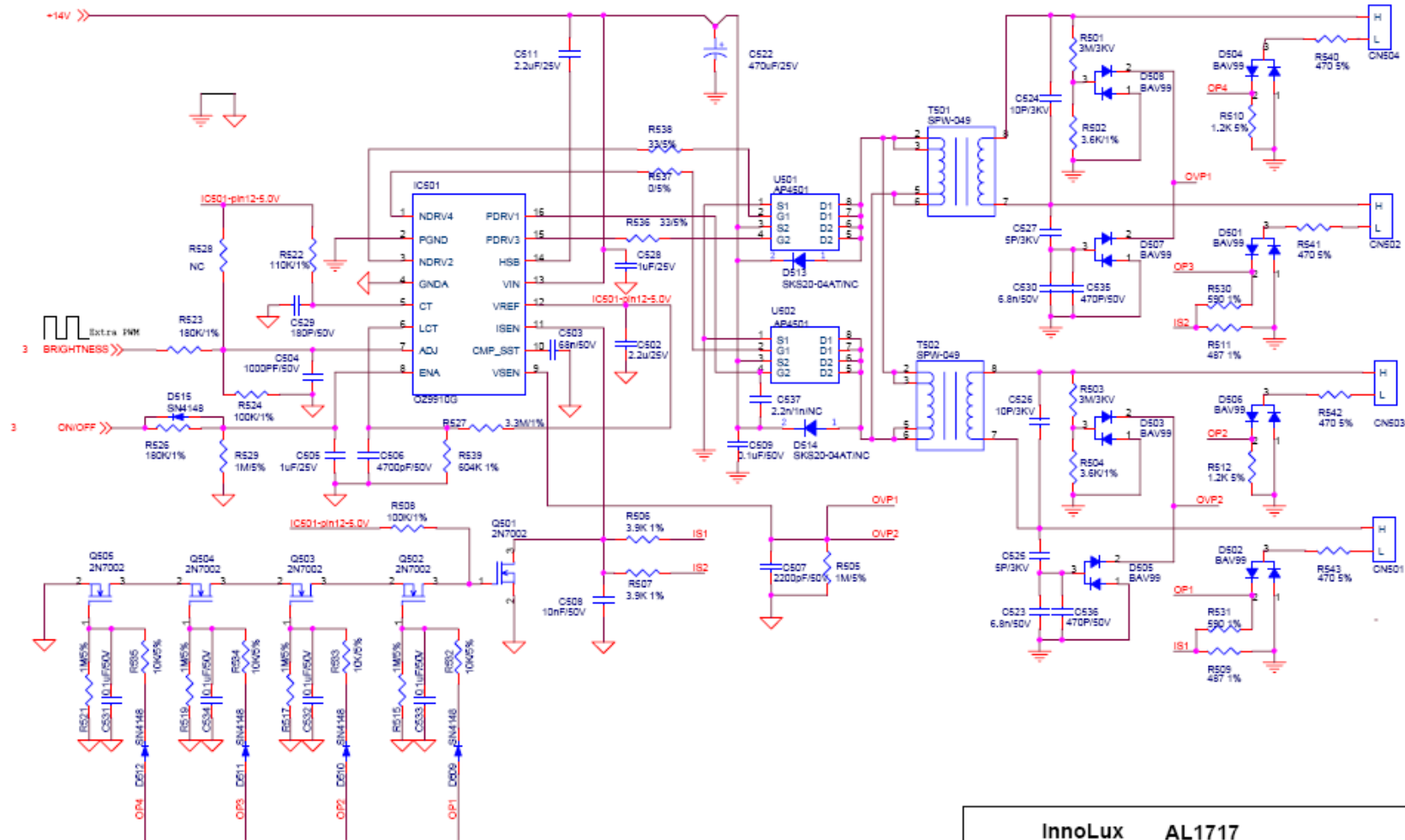

InnoLux AL1717		
Document Number : new	SIZE : Custom	APPRO BY :
TITLE : Inverter DVT		CHECK BY :
DATE : 2006-01-05	DRAWN BY :	
SHEET 4 OF 4	Rev : 1A	

Project Name	AL1717 VGA LCD Monitor (LE1718-6E0)
---------------------	-------------------------------------

REVISION HISTORY

Date	Author	Version	Comments	Remark
2006-03-03	kidd zhang	V01	First edition	

APPROVED TO RELEASE

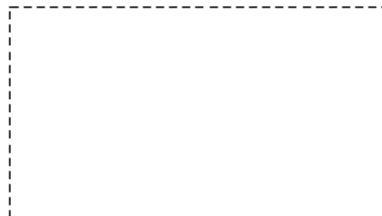

InnoLux		AL1717
Document Number :	SIZE :	APPRO BY :
0921351063	A4	
TITLE :		CHECK BY :
History		
DATE :	2006-03-03	DRAWN BY :
SHEET	1 OF 5	Rev : V01

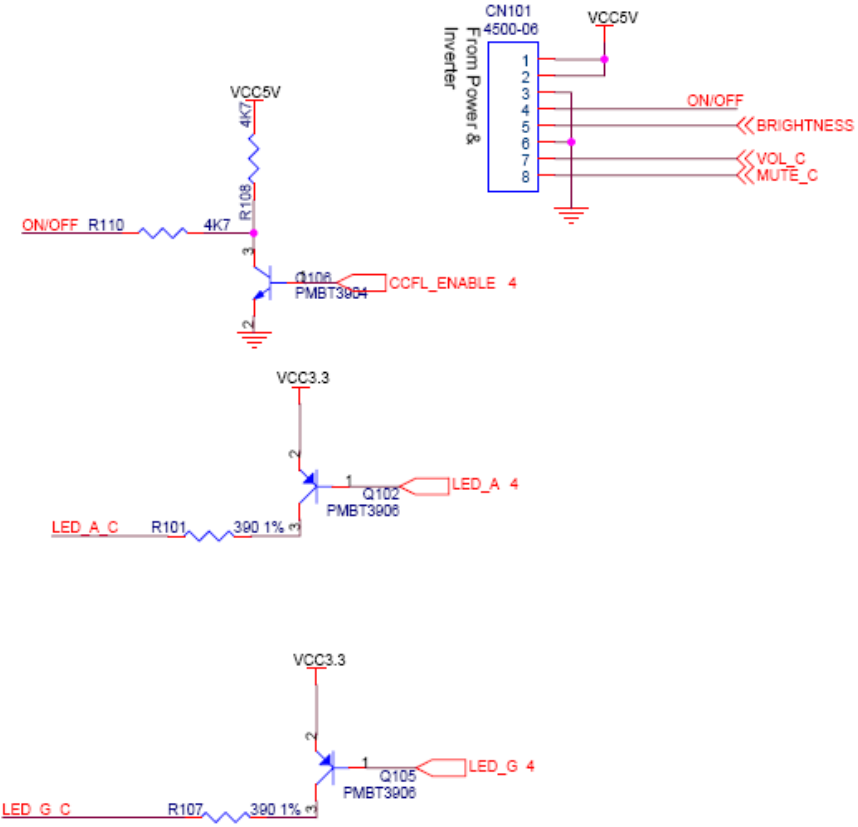
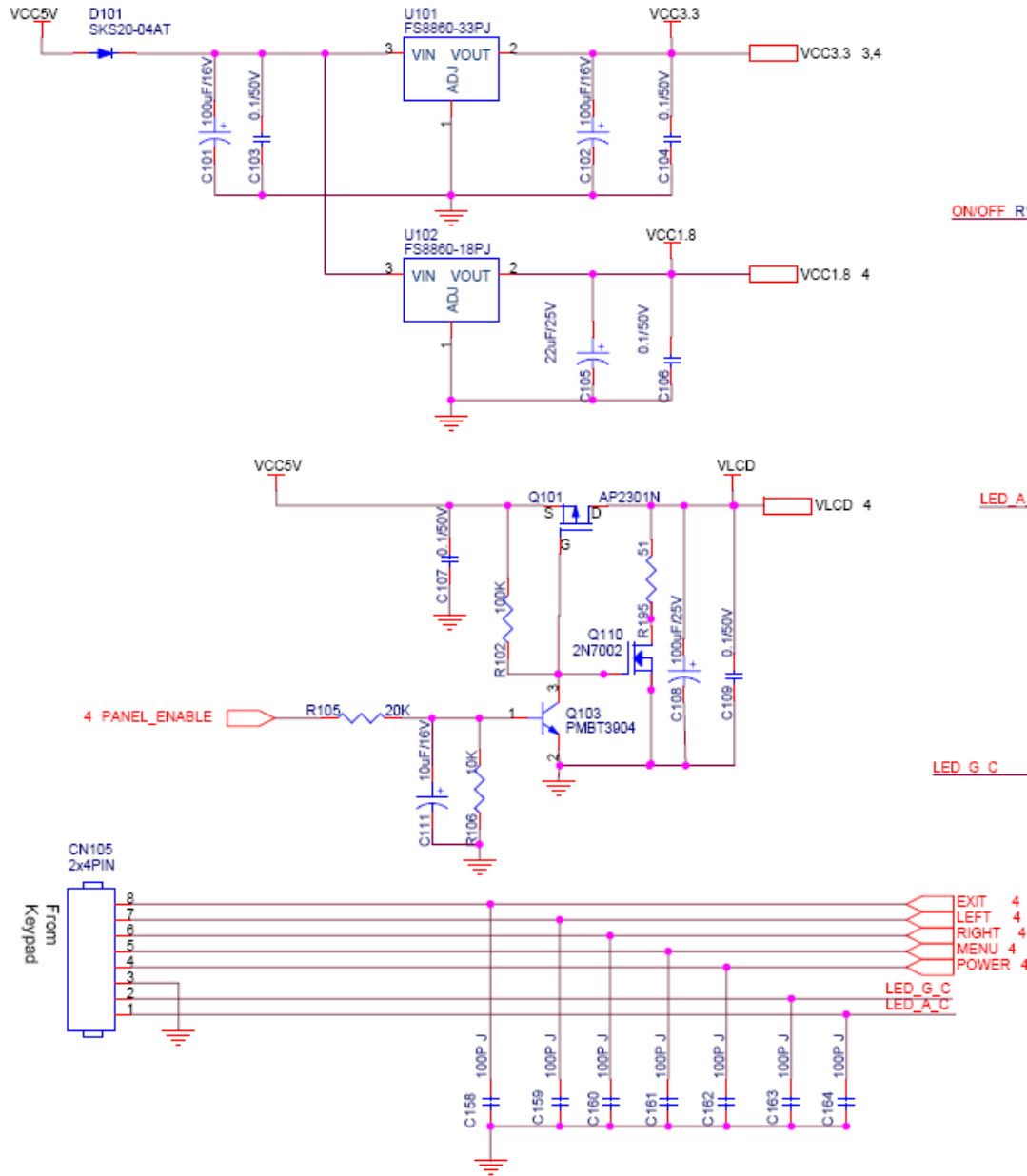

InnoLux		AL1717
Document Number :	SIZE :	APPRO BY :
0921351063	A4	
TITLE :		CHECK BY :
DC to DC		
DATE :	2006-03-03	DRAWN BY :
SHEET	2 OF 5	Rev : V01

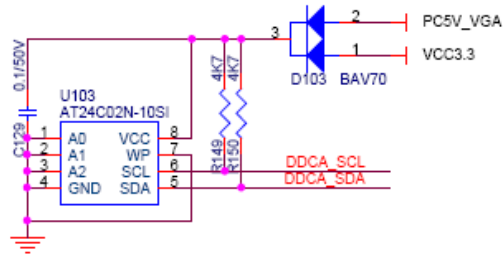
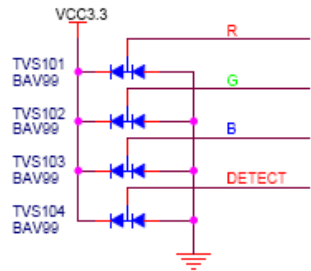
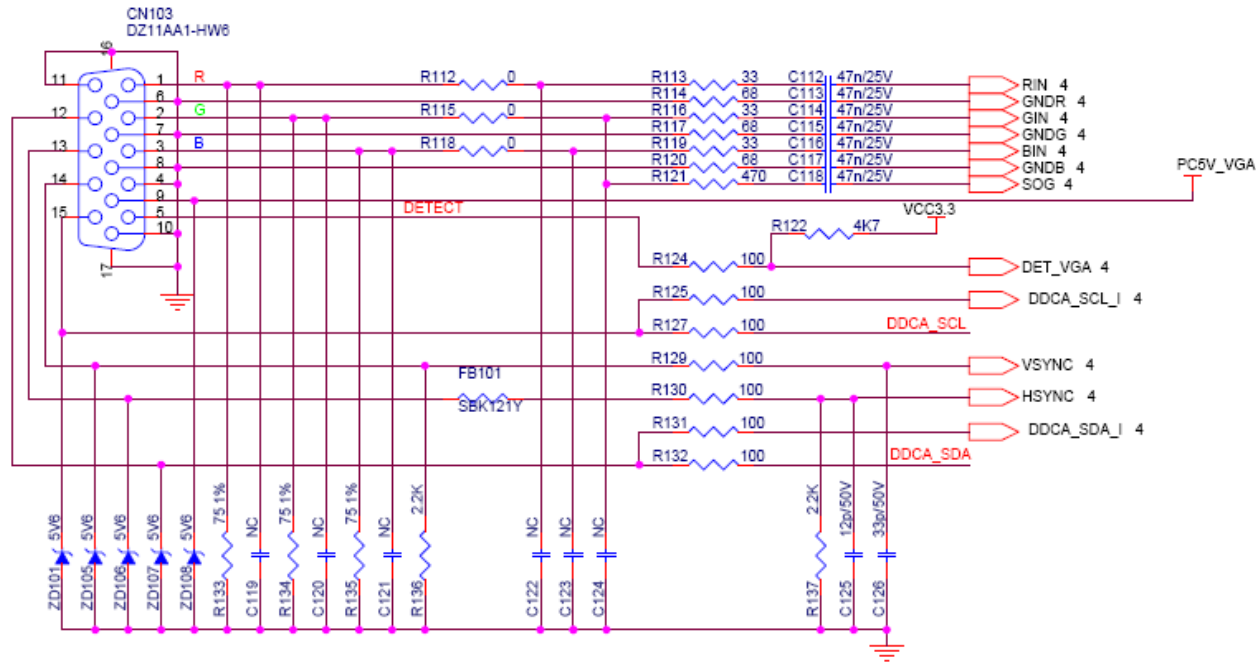

InnoLux		AL1717	
Document Number :	0921351063	SIZE :	A4
TITLE :			INPUT
DATE :	2006-03-03	DRAWN BY :	
SHEET	3 OF 5	Rev :	V01

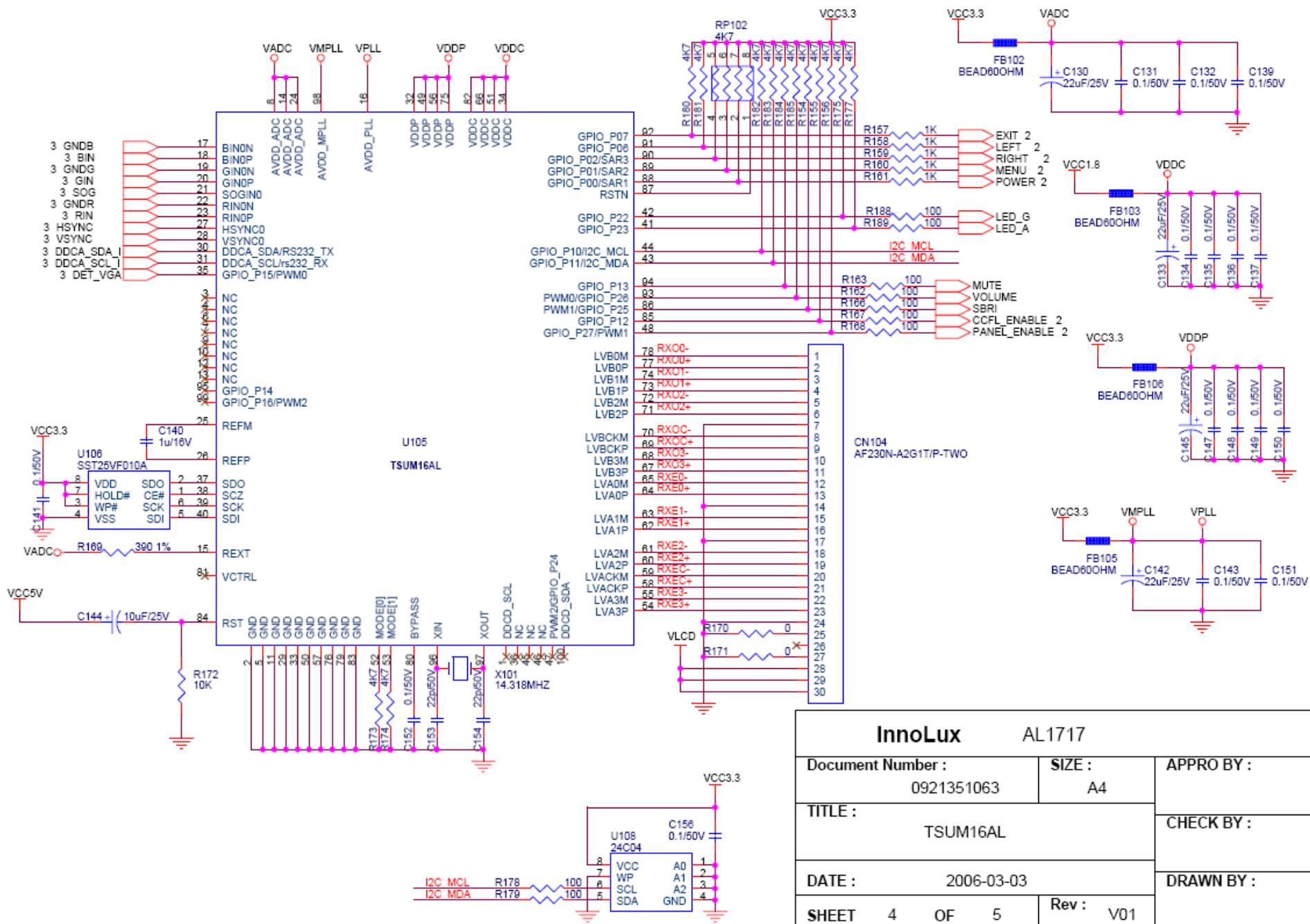

InnoLux AL1717	
Document Number : 0921351063	SIZE : A4
TITLE : TSUM16AL	
DATE : 2006-03-03	APPRO BY :
DRAWN BY :	
SHEET 4 OF 5	Rev : V01

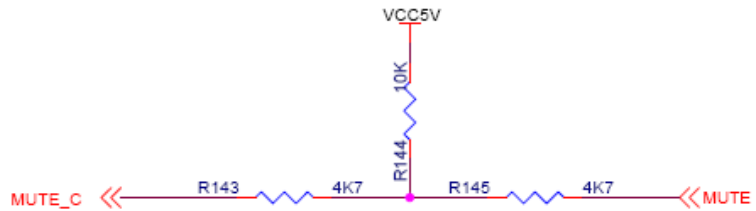
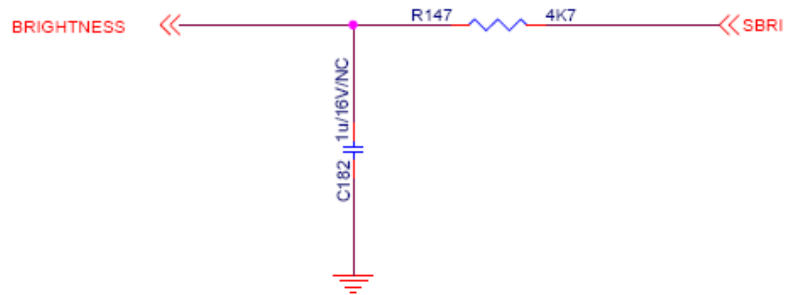
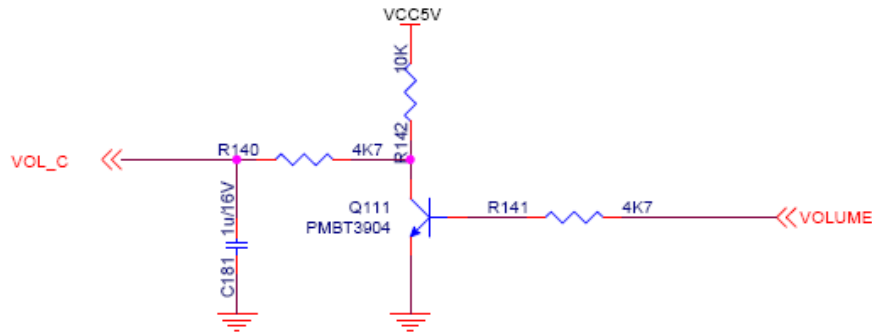

InnoLux		AL1717	
Document Number : 0921351063		SIZE : A	APPRO BY :
TITLE : VOLUME and MUTE			CHECK BY :
DATE : 2006-03-03		DRAWN BY :	
SHEET 5	OF 5	Rev : V01	

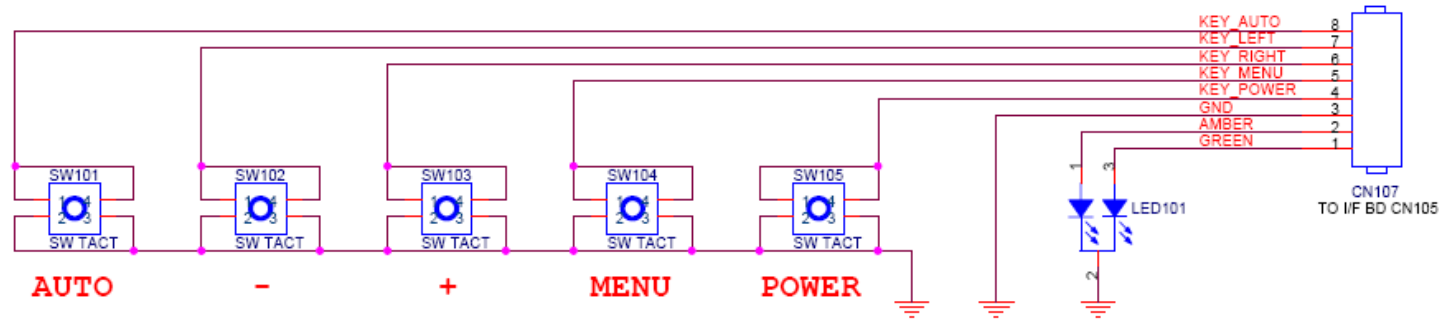

InnoLux AL1717		
Document Number : 0921351064	SIZE : A4	APPRO BY :
TITLE : keyboard		CHECK BY :
DATE : 2006-03-03		DRAWN BY :
SHEET 1 OF 2	Rev : V01	

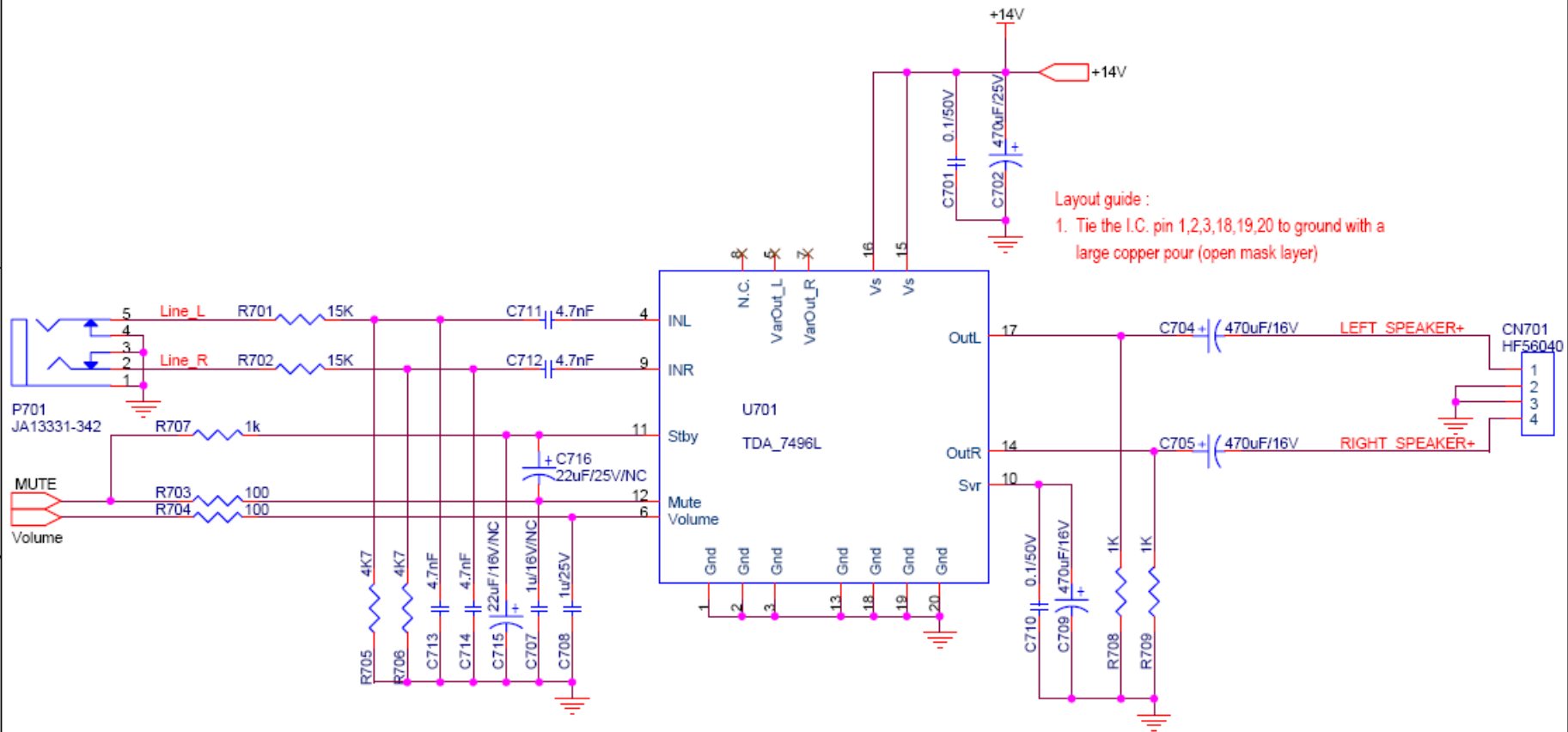

Layout guide :
 1. Tie the I.C. pin 1,2,3,18,19,20 to ground with a large copper pour (open mask layer)

InnoLux		AL1717	
Document Number :	0921351064	SIZE :	A
TITLE :	Audio	APPRO BY :	
DATE :	2006-03-04	CHECK BY :	
SHEET	2 OF 2	DRAWN BY :	
		Rev :	1A

Attachment 3- PCB Layout

LAYER	SILKSCREEN TOP			
PCB NO :	ILIF-013	REV :	A	DESIGNER: Helen Chen
FILE NAME :	ILIF-013 RA.PCB	DATE :	2006/02/20	

490571300100R

