

SERVICE MANUAL

19" LCD MONITOR

MM19D



THESE DOCUMENTS ARE FOR REPAIR SERVICE INFORMATION ONLY. EVERY REASONABLE EFFORT HAS BEEN MADE TO ENSURE THE ACCURACY OF THIS MANUAL; WE CANNOT GUARANTEE THE ACCURACY OF THIS INFORMATION AFTER THE DATE OF PUBLICATION AND DISCLAIMERS RE LIABILITY FOR CHANGES, ERRORS OR OMISSIONS.

Table of Content	
Revision List	3
1. Monitor Description	4
2. LCD Monitor Description	5
3. Operating Instructions	6
3.1 General Instructions.....	6
3.2 Front Panel Control.....	6
3.3 Adjusting the Picture.....	7
4. Input/Output Specification	9
4.1 Input Signal Connector.....	9
4.2 Power Supply Requirements.....	9
4.3 Factory Preset Display Modes.....	10
4.4 Panel Specification.....	11
4.4.1 General Description.....	11
4.4.1 Display Characteristics.....	11
4.4.2 Optical Characteristics.....	12
4.4.3 Electrical Characteristics.....	13
5. Block Diagram	14
5.1 Monitor Exploded View.....	14
5.2 Software Flowing Chart.....	15
5.3 Electrical Block Diagram.....	17
5.3.1 Main Board.....	17
5.3.2 Inverter/Power Board.....	18
6. Schematic	19
6.1 Main Board.....	19
6.2 Power Board.....	25
7. PCB Layout	29
7.1 Main Board.....	29
7.2 Power Board.....	30
7.3 Key Board.....	30
8. Maintainability	31
8.1 Equipments and Tools Requirement.....	31
8.2 Trouble Shooting.....	32
8.2.1 Main Board.....	32
8.2.2 Inverter/Power Board.....	35
8.2.3 Keypad Board.....	37
9. White-Balance, Luminance adjustment	38
10. EDID Content	40
11. BOM List	41

Revision List

Version	Date	Revision History	TPV Model Name
A00	Apr-18-06	Initial Release	T980KH4DTAUSNP

<http://www.wiel.net>

1. Monitor Specifications

Items	Description	
LCD Panel	Driving system	TFT Color LCD
	Type	HSD190ME13
	Size	48.0cm(19.0")
	Pixel pitch	0.294mm (H) x 0.294mm (V)
	Viewable angle	160(H) 160(V)(CR>5)
	Response time	8 ms
Input	Sync. Type	H/V TTL
	Input Signal	15Pin Analog
	H-Frequency	30kHz – 80kHz
	V-Frequency	55-75Hz
Power Consumption	ON Mode	<55W
	OFF Mode	<2W
Display Color	16.2M (6-bits+FRC)	
Contrast Ratio	700:1	
Dot Clock	135MHz	
White Luminance	300cd/m ²	
Max. Resolution	1280 x1024	
Plug & Play	VESA DDC2B™	
Power Source	100~240VAC,47~63Hz	
Maximum Screen Size	Horizontal : 376.32mm Vertical: 301.056mm	
Environmental Conditions	Operating Temp: 0°C to 35°C Storage Temp: -20°C to 60°C Operating Humidity: 45% to 85%	

2. LCD Monitor Description

The LCD MONITOR will contain a main board, a power board, a keypad board which house the flat panel control logic, brightness control logic and DDC.

The power board will provide AC to DC Inverter voltage to drive the backlight of panel and the main board chips each voltage.

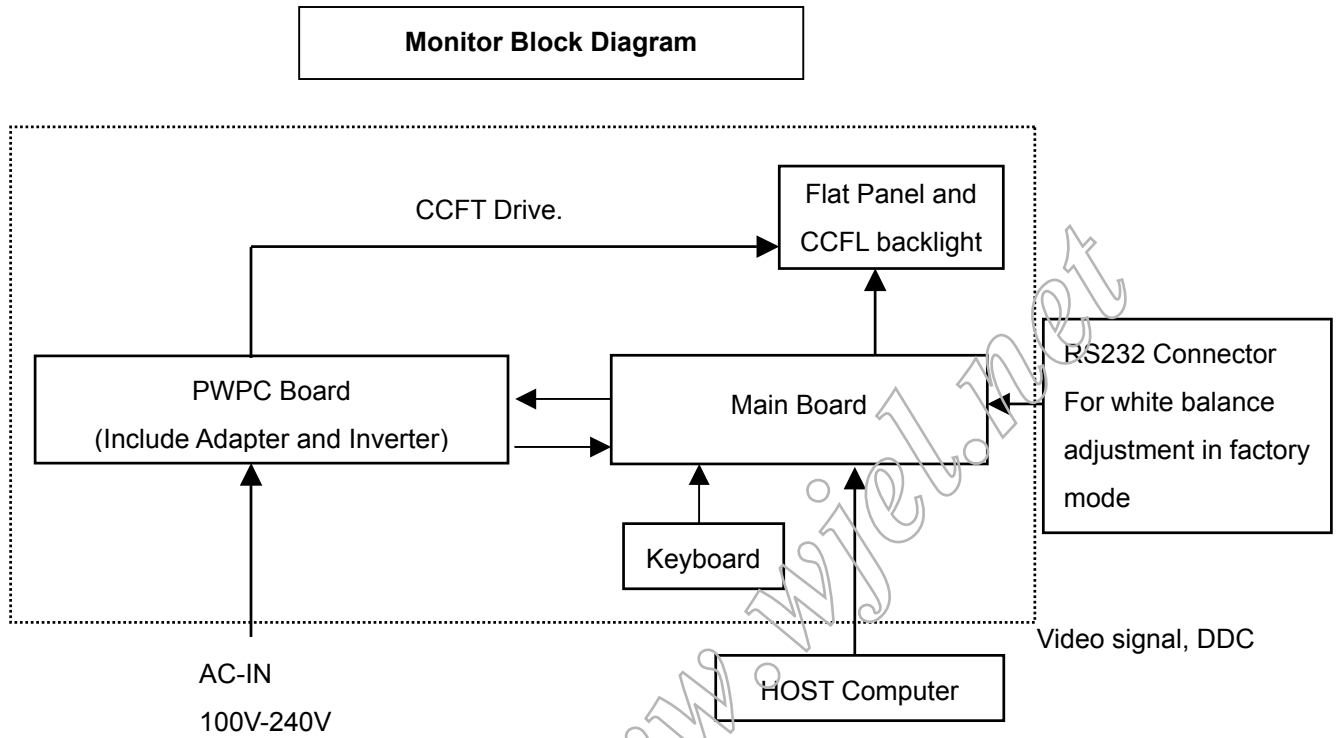

3. Operating Instructions

3.1 General Instructions

Press the power button to turn the monitor on or off. The other control buttons are located in front panel of the monitor. By changing these settings, the picture can be adjusted to your personal preferences.

- The power cord should be connected.
- Connect the video cable from the monitor to the video card.
- Press the power button to turn on the monitor position. The power indicator will light up.

3.2 Front Panel Control

- Power Button:

When pressed, the monitor enters the off mode, and the LED turns blank. Press again to restore normal status.

- Left / Right Button:

The Left/Right Button is used to control the monitor functions. Press to switch functions or adjust settings.

- Auto Adjust Key:

The Auto Adjust Key is used to automatically set the H Position, V Position, Clock and Phase.

- Power Indicator:

Blue — Power On mode.

Amber — Power Saving mode.

Dark —Power Off Mode.

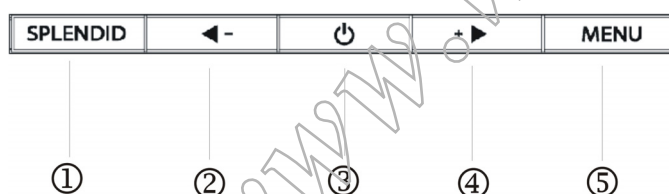

NO.	Name	Within OSD	Without OSD
①	Splendid Button	Exit OSD or back to previous menu	1. Activate Scenario selection menu. 2. Automatically adjust the image to its optimized position, clock, and phase by pressing the button for 2 seconds.
②	- / ◀ Button	Decrease the level of the function select or move to the previous function.	Activate Contrast adjustment menu
③	Power Button	Switch the LCD monitor on or off. Blue: normal operation mode. Amber: power saving mode. Dark: power off mode	Switch the LCD monitor on or off. Blue: normal operation mode. Amber: power saving mode. Dark: power off mode
④	+ / ▶ Button	Increase the level of the function select or move to the next function.	Activate Brightness adjustment menu.
⑤	Menu Button	Enter/select the icon highlighted .	Activate the OSD main menu.

3.3 Adjusting The Picture





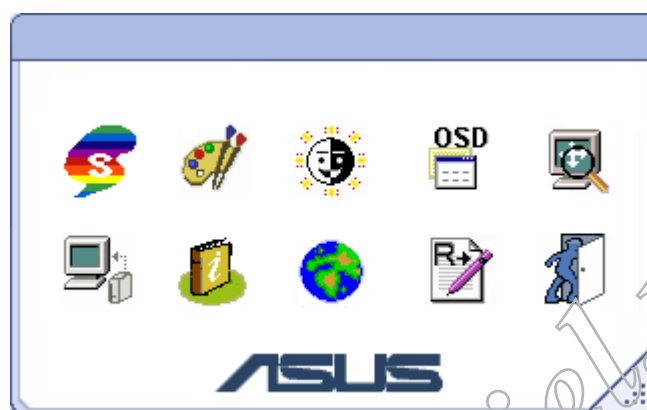



















Adjustment steps:

1. Press the MENU-button to activate the OSD window.
2. Press < or > to select the desired function.
3. Press the MENU-button to select the function that you want to adjust.
4. Press < or > to change the settings of the current function.
5. To exit and save, select the exit function, or leave the monitor alone for 10 seconds. If you want to adjust any other function, repeat steps 2-4.



OSD TABLE:

Main Menu Item	Main Menu Icon	Sub Menu Item	Sub Menu Icon	Description			
Scenario		Scenery Mode		Advance for scenery use with Splendid™ Video Enhancement			
		Text Mode		Advance for generic Windows use (Splendid™ Off)			
		Theater Mode		Advance for movie use with Splendid™ Video Enhancement			
		Game Mode		Advance for game use with Splendid™ Video Enhancement			
		Night Mode		Advance for dark-display use with Splendid™ Video Enhancement			
Color		RGB		R		Adjust red gain	
				G		Adjust green gain	
				B		Adjust blue gain	
		Skin Tone		Reddish		Select reddish skin stone	
				Natural		Select natural skin stone	

				Yellowish		Select yellowish skin stone
		Color Temperature		Cool		The image appears bluer. (9300° K)
				Normal		Normal image color. (7500° K)
				Warm		The image appears redder. (6500° K)
Luminance		Brightness		Adjust the brightness level		
		Contrast		Adjust the contrast level		
OSD Setup		H-Position		Adjust the horizontal position of the OSD		
		V-Position		Adjust the vertical position of the OSD		
		OSD Timeout		Adjust the OSD timeout		
Image Setup		Focus		Phase		Adjust the image Phase to reduce Horizontal-line noise of the image
				Clock		Adjust the image Clock to reduce Vertical-line noise of the image
		Image Position		H-Position		Adjust the horizontal position of the image
				V-Position		Adjust the vertical position of the image
		Auto		Auto adjust the horizontal/vertical positions, phase and clock of the image		
Information		Show the resolution, H/V frequency and input port of current input timing				
Language		Select the language you like				
Reset		Recall factory setting				
Exit		Exit OSD				

4. Input/Output Specification

4.1 Input Signal Connector

Analog Connector

Pin No.	Description	Pin No.	Description
1.	Red	9.	+5V
2.	Green	10.	Logic Ground
3.	Blue	11.	Monitor Ground
4.	Monitor Ground	12.	DDC-Serial Data
5.	DDC-Return	13.	H-Sync
6.	R-Ground	14.	V-Sync
7.	G-Ground	15.	DDC-Serial Clock
8.	B-Ground		

VGA connector layout

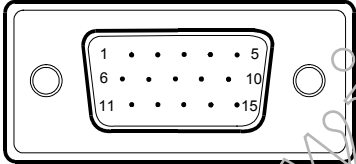

4.2 Power Supply Requirement

A/C Line voltage range	: 100 V ~ 240 V
A/C Line frequency range	: 50 ± 3Hz, 60 ± 3Hz
Input Current	: 1.5A max at 100V; 0.8A max at 240 V
Peak surge current	: < 60A peak at 240 VAC and cold starting < 30A peak at 120VAC and cold starting
Leakage current	: < 3.5mA
Power line surge	: No advance effects (no loss of information or defect) with a maximum of 1 half-wave missing per second

4.3 Factory Preset Display Modes

VESA MODES							
Mode	Resolution	Total	Horizontal		Vertical		Nominal Pixel Clock (MHz)
			Nominal Frequency +/- 0.5kHz	Sync Polarity	Nominal Freq. +/- 1 Hz	Sync Polarity	
VGA	640x480@60Hz	800 x 525	31.469	N	59.940	N	25.175
	640x480@72Hz	832 x 520	37.861	N	72.809	N	31.500
	640x480@75Hz	840 x 500	37.500	N	75.00	N	31.500
SVGA	800x600@56Hz	1024 x 625	35.156	N/P	56.250	N/P	36.000
	800x600@60Hz	1056 x 628	37.879	P	60.317	P	40.000
	800x600@72Hz	1040 x 666	48.077	P	72.188	P	50.000
	800x600@75Hz	1056x625	46.875	P	75.000	P	49.500
XGA	1024x768@60Hz	1344x806	48.363	N	60.004	N	65.000
	1024x768@70Hz	1328x806	56.476	N	70.069	N	75.000
	1024x768@75Hz	1312x800	60.023	P	75.029	P	78.750
	1024x768@72Hz	1304x798	57.7	P	72	P	78.4
SXGA	1152x864@75Hz	1600x900	67.5	P	75	P	108
	1280x1024@60Hz	1688x1066	63.981	P	60.020	P	108.000
	1280x1024@75Hz	1688x1066	79.976	P	75.025	P	135.000
	1280x960@60Hz	1800x1000	60	P	60	P	108
	1280x1024@70Hz		74.4	P	70	P	124.9
	1280x1024@72Hz		77.9	P	72	P	134.6
IBM MODES							
Mode	Resolution	Total	Horizontal		Vertical		Nominal Pixel Clock (MHz)
			Nominal Frequency +/- 0.5kHz	Sync Polarity	Nominal Freq. +/- 1 Hz	Sync Polarity	
DOS*	720x400@70Hz	900 x 449	31.469	N	70.087	P	28.322
DOS	640x350@70Hz	800 x 449	31.469	P	70.087	N	25.175
MAC MODES							
VGA	640x480@67Hz	864x525	35.000	N	66.667	N	30.240
SVGA	832x624@75Hz	1152x667	49.725	N	74.551	N	57.2832

4.4 Panel Specification

4.4.1 General Description

- 19" SXGA TFT LCD Panel
- 4 CCFLs Backlight System
- Supported SXGA (V:1024 lines, H:1280 pixels) Resolution
- Supported to 75Hz Refresh Rate
- LCD Timing Controller
- RoHS Compliance
- VESA Compatible

4.4.2 Display Characteristics

Item	Specification		Unit
Outline dimension	396*324 *17.5(Typ)		mm
Display area	376.32 (H) x301.056 (V) (19.0" diagonal)		mm
Number of Pixel	1280(H) x 1024(V)		Pixels
Pixel pitch	0.294(H) x 0.294(V)		mm
Pixel arrangement	RGB Vertical Stripe		
Display color	16.2M (6-bits+FRC)		
Display mode	Normally white		
Surface treatment	Antiglare, Hard-Coating(3H)		
Weight	2600g(Typ.)		g
Back-light	4-CCFLs, Top & bottom edge side		
Input signal	2-ch LVDS		
Power consumption	System	3.05	W
	B/L	20	
Optimum viewing direction	6 o'clock		

4.4.3 Optical Characteristics

Item	Symbol	Condition	Min.	Typ.	Max.	Unit	Note
Contrast	CR		450	700	--		(1)(2)
Response time	Rising	TR +TF	--	2	4	msec	(1)(3)
	Falling		--	6	8		
White luminance (center of screen)	Y_L	$\theta=0^\circ$	240	300	--	cd/m ²	(1)(4) (IL=7.5mA)
Color chromaticity (CIE1931)	Red	Rx	$\theta=0^\circ$ $\phi=0^\circ$ Normal viewing angle	0.614	0.644	0.674	(1)(4)
		Ry		0.298	0.328	0.358	
	Green	Gx		0.260	0.290	0.320	
		Gy		0.584	0.614	0.644	
	Blue	Bx		0.112	0.142	0.172	
		By		0.049	0.079	0.109	
	White	Wx		0.280	0.310	0.340	
		Wy		0.300	0.330	0.360	
Viewing angle	Hor.	θ_L	CR>10	65	75	--	
		θ_R		65	75	--	
	Ver.	θ_H		60	70	--	
		θ_L		55	65	--	
Viewing angle	Hor.	θ_L	CR>5	--	80	--	
		θ_R		--	80	--	
	Ver.	θ_H		--	80	--	
		θ_L		--	80	--	
Brightness uniformity	B_{UNI}	$\theta=0^\circ$ $\phi=0^\circ$	75	--	--	%	(6)

4.4.4 Electrical Characteristics

1. TFT LCD Module

Item	Symbol	Min.	Typ.	Max.	Unit	Note	
Voltage of power supply	V _{DD}	4.5	5.0	5.5	V		
Current of power supply	White	I _{DD0}	430	530	630	mA	(1)
	V-Color	I _{DD1}	510	610	710	mA	(1)
	Mosaic	I _{DD2}	660	760	860	mA	(1)
Vsync frequency	f _V	56	60	76	Hz	(2)	
Hsync frequency	f _H	64	64	80	KHz		
Frequency	f _{DCLK}	50	54	67.5	MHz		
Input rush current	I _{RUSH}	--	--	3.0	A	(3)	

2. Backlight Unit

Item	Symbol	Min.	Typ.	Max.	Unit	Note
Lamp current	IL	3.0	7.5	9.0	mA(rms)	(1)
Lamp voltage	VL	603	670	737	V(rms)	I _L =7.5mA
Frequency	fL	40	50	80	KHz	(2)
Operating Lifetime	Hr	50,000	--	--	Hour	6.5mA(3)
	Hr	40,000	--	50,000	Hour	7.5mA(3)
Startup voltage	Vs	1595	--	--	V(rms)	at 25°C
		1870				at 0°C

5. Block Diagram

5.1 Monitor Exploded View

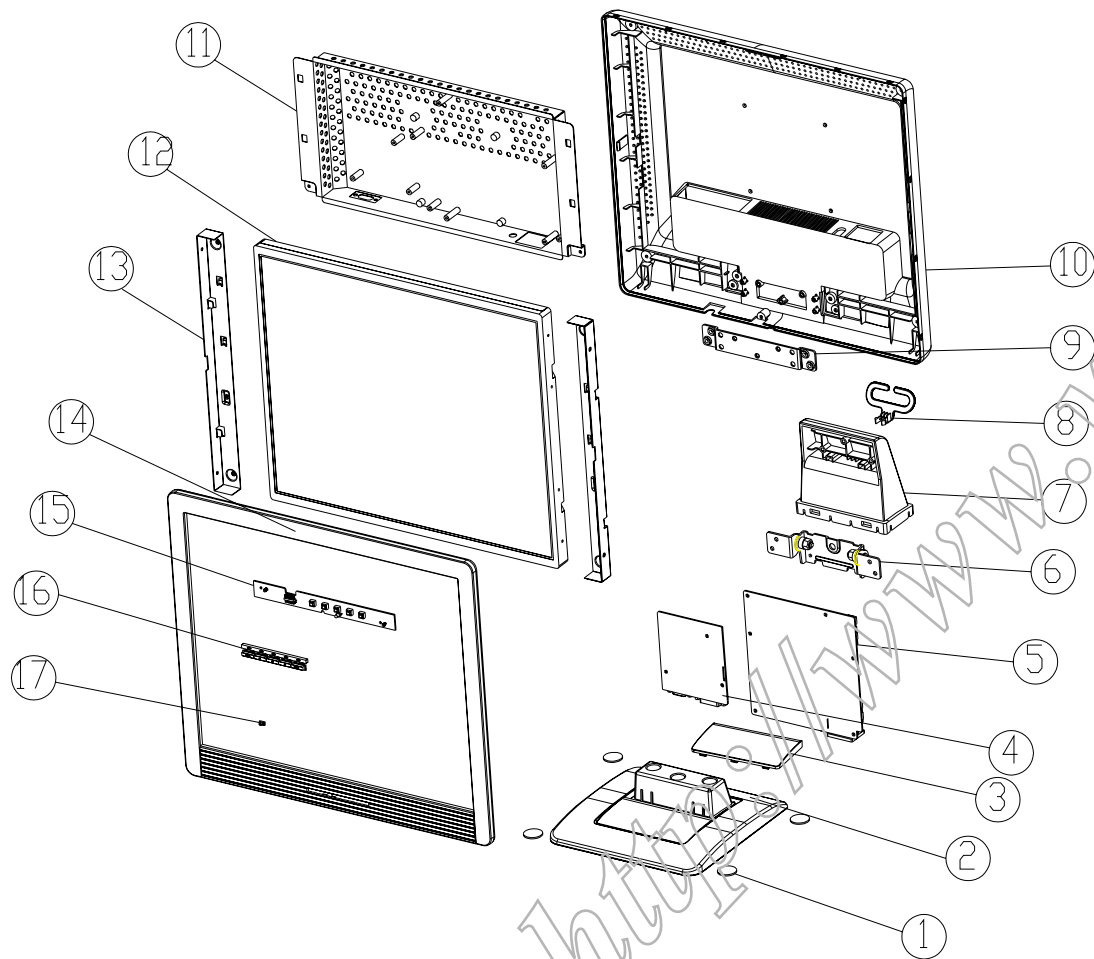

ITEM	NAME	TYPE
1	RUBBER FOOT	PART
2	BASE UP	PART
3	BASE DOWN	PART
4	MAIN BOARD	ASSEMBLY
5	POWER BOARD	ASSEMBLY
6	HINGE	PART
7	STAND	PART
8	CLAMP	PART
9	HINGE BKT	PART
10	REARCOVER	PART
11	SHIELDING	PART
12	PANEL	PART
13	PANEL BKT	PART
14	BEZEL	PART
15	KEY BOARD	ASSEMBLY
16	KEY PAD	PART
	LENS	PART

5.2 Software Flowing Chart

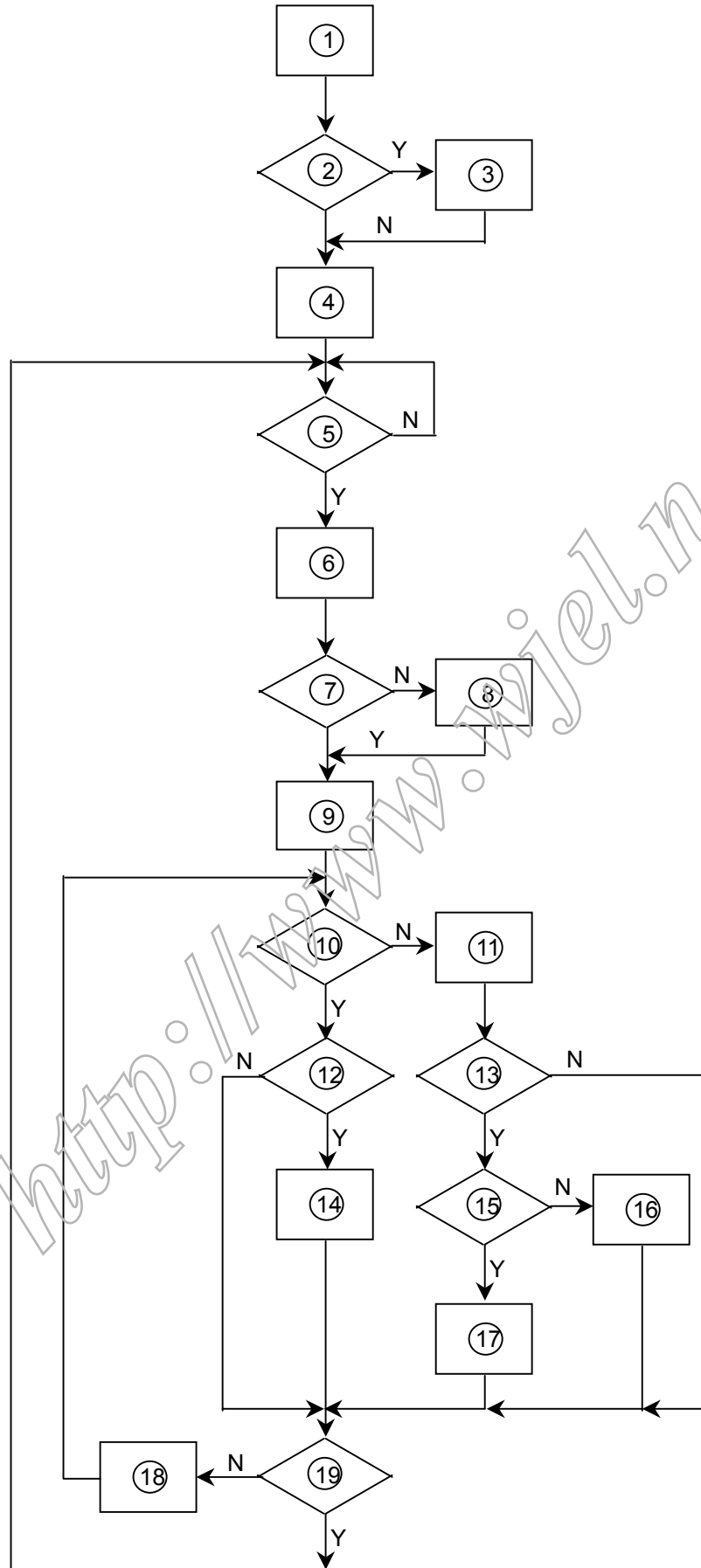

REMARK:

1) MCU initialize.
2) Is the EEprom blank?
3) Program the EEprom by default values.
4) Get the PWM value of brightness from EEprom.
5) Is the power key pressed?
6) Clear all global flags.
7) Are the AUTO and SELECT keys pressed?
8) Enter factory mode.
9) Save the power key status into EEprom. Turn on the LED and set it to green color. Scalar initialize.
10) In standby mode?
11) Update the lifetime of back light.
12) Check the analog port, are they're any signals coming?
13) Does the scalar send out an interrupt request?
14) Wake up the scalar.
15) Are there any signals coming from analog port?
16) Display "No connection Check Signal Cable" message. And go into standby mode after the message disappear.
17) Program the scalar to be able to show the coming mode.
18) Process the OSD display.
19) Read the keyboard. Is the power key pressed?

5.3 Electrical Block Diagram

5.3.1 Main Board

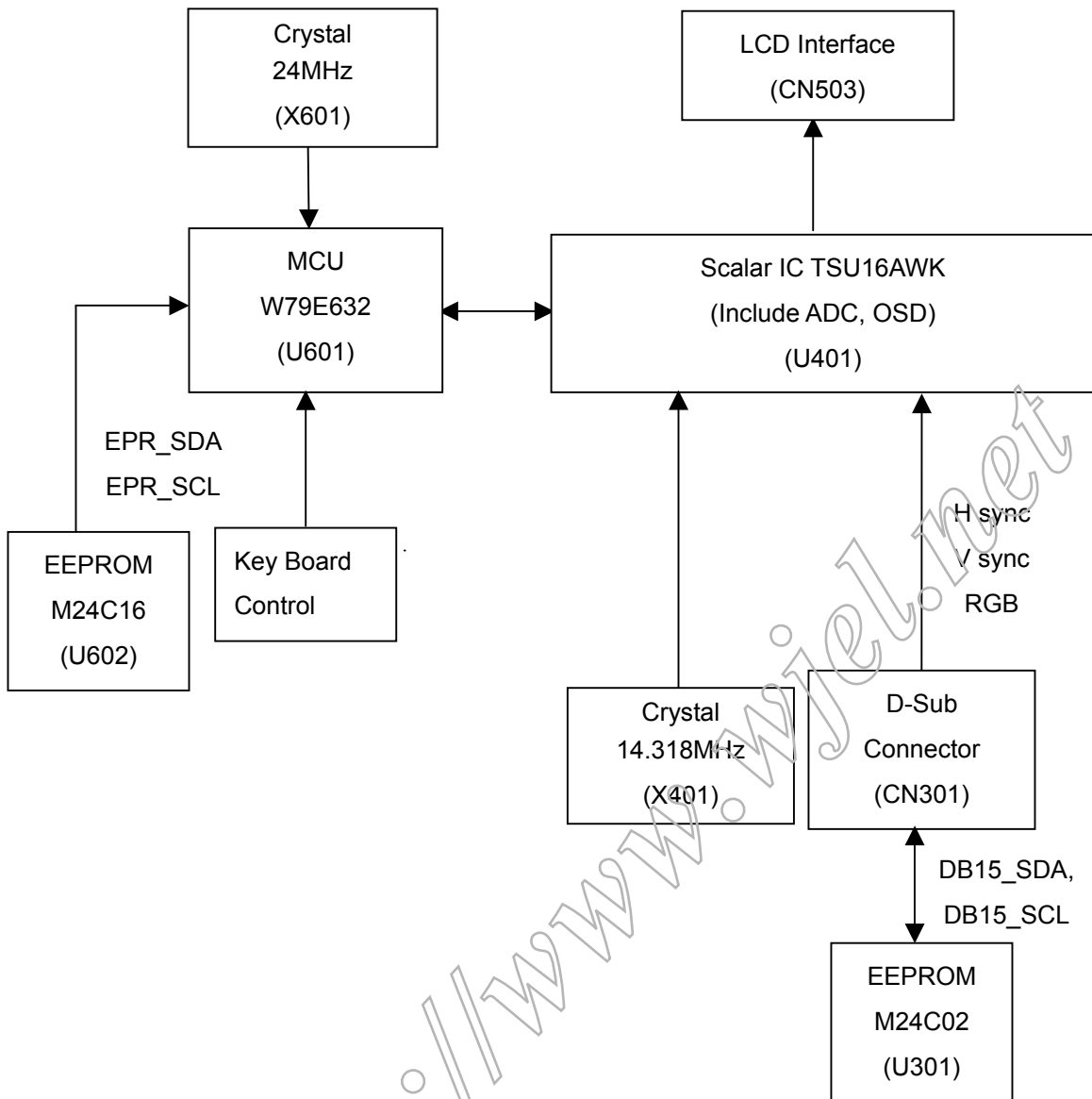

5.3.2 Inverter/Power Board

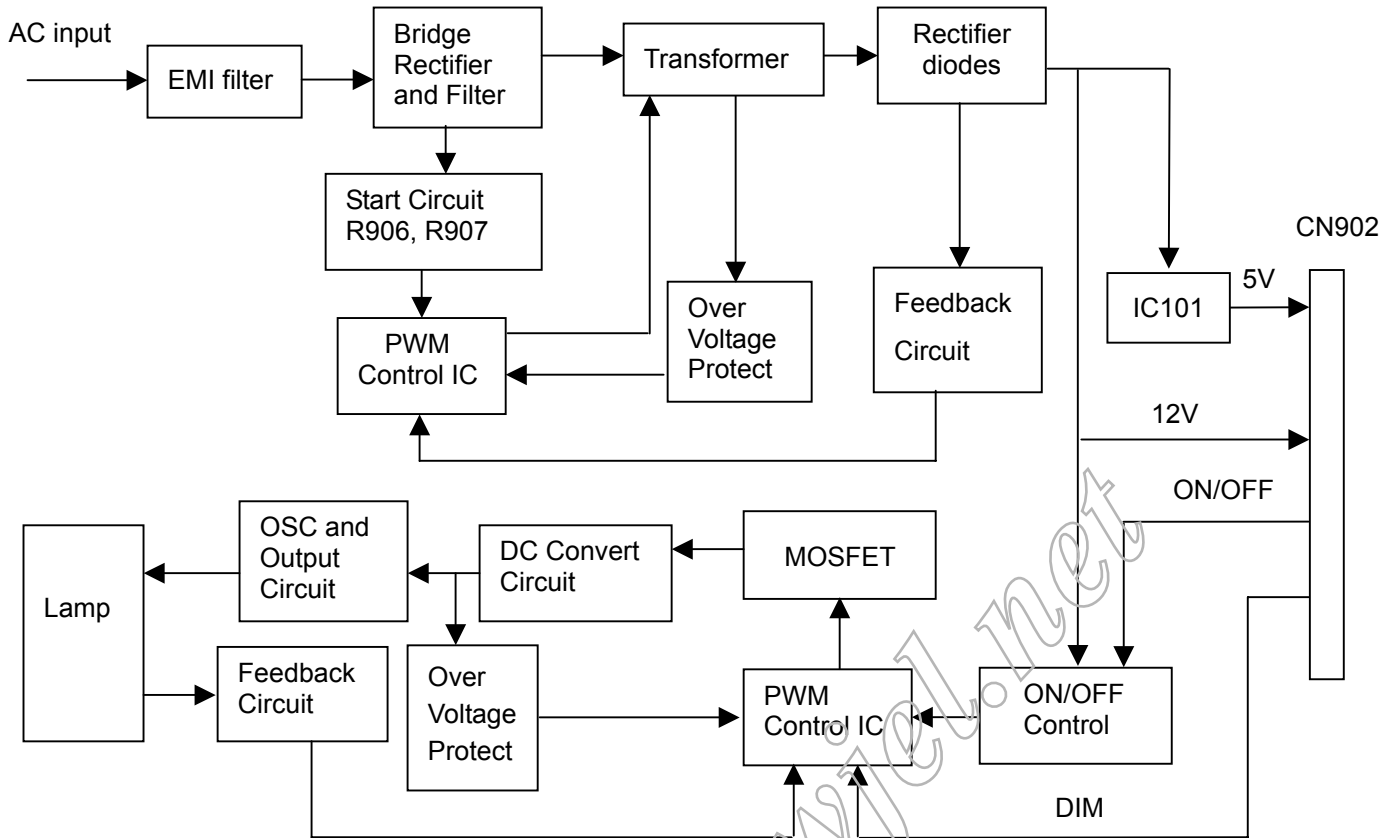

6. Schematic

6.1 Main Board

715G1423-3-512

TSU16/56AK SCHEMATIC

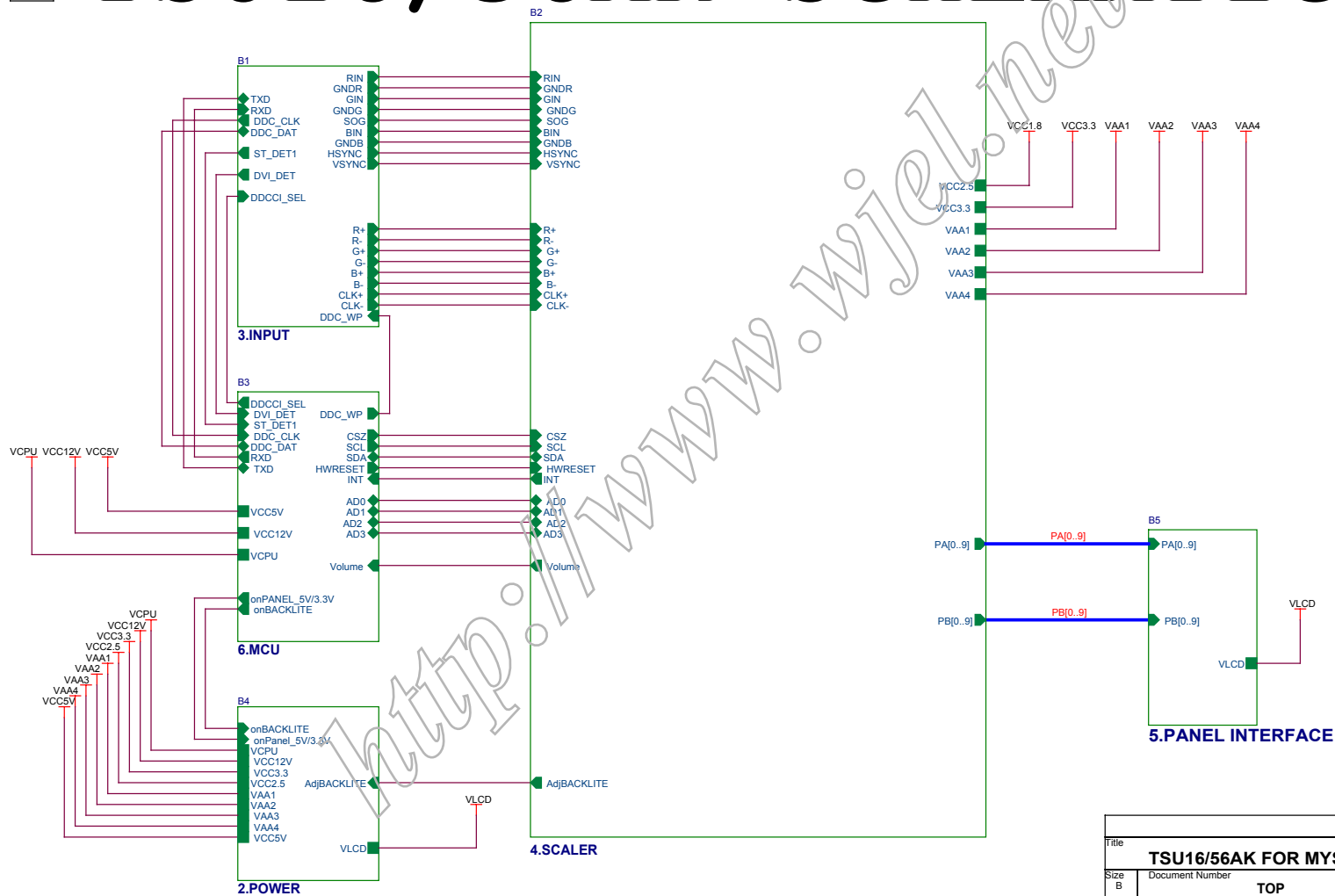

Title			
TSU16/56AK FOR MYSON 512 SWITCH			
Size	Document Number	TOP	Rev
B			B
Date:	Wednesday, March 09, 2005	Sheet	1 of 6

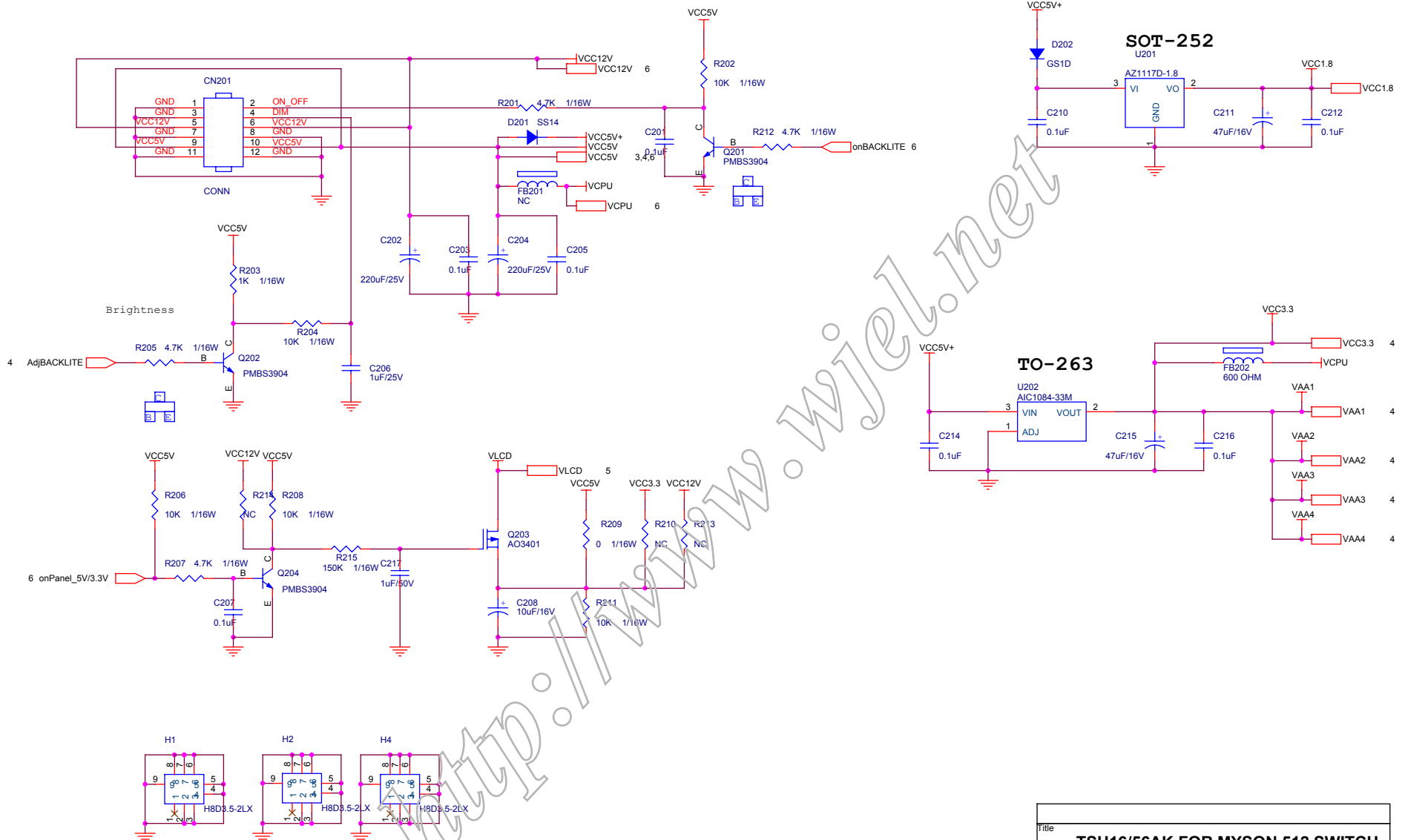

Title		
TSU16/56AK FOR MYSON 512 SWITCH		
Size	Document Number	Rev
B	POWER	B
Date:	Wednesday, March 09, 2005	Sheet 2 of 6

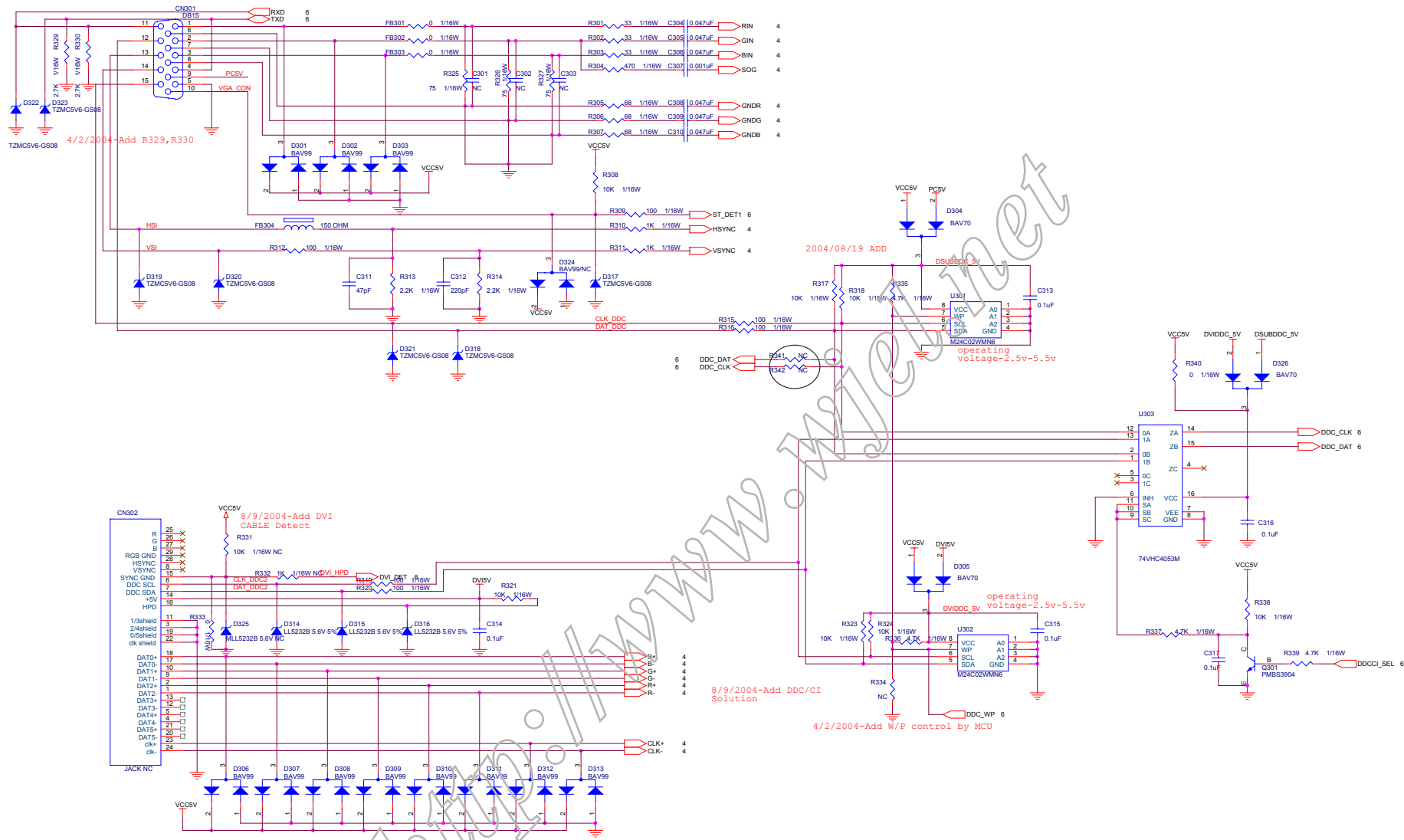

File			
TSU16/56AK FOR MYSON 512 SWITCH			
Size	Document Number	Rev	
C	INPUT	B	
Date	Wednesday, March 08, 2005	Sheet	3 of 6

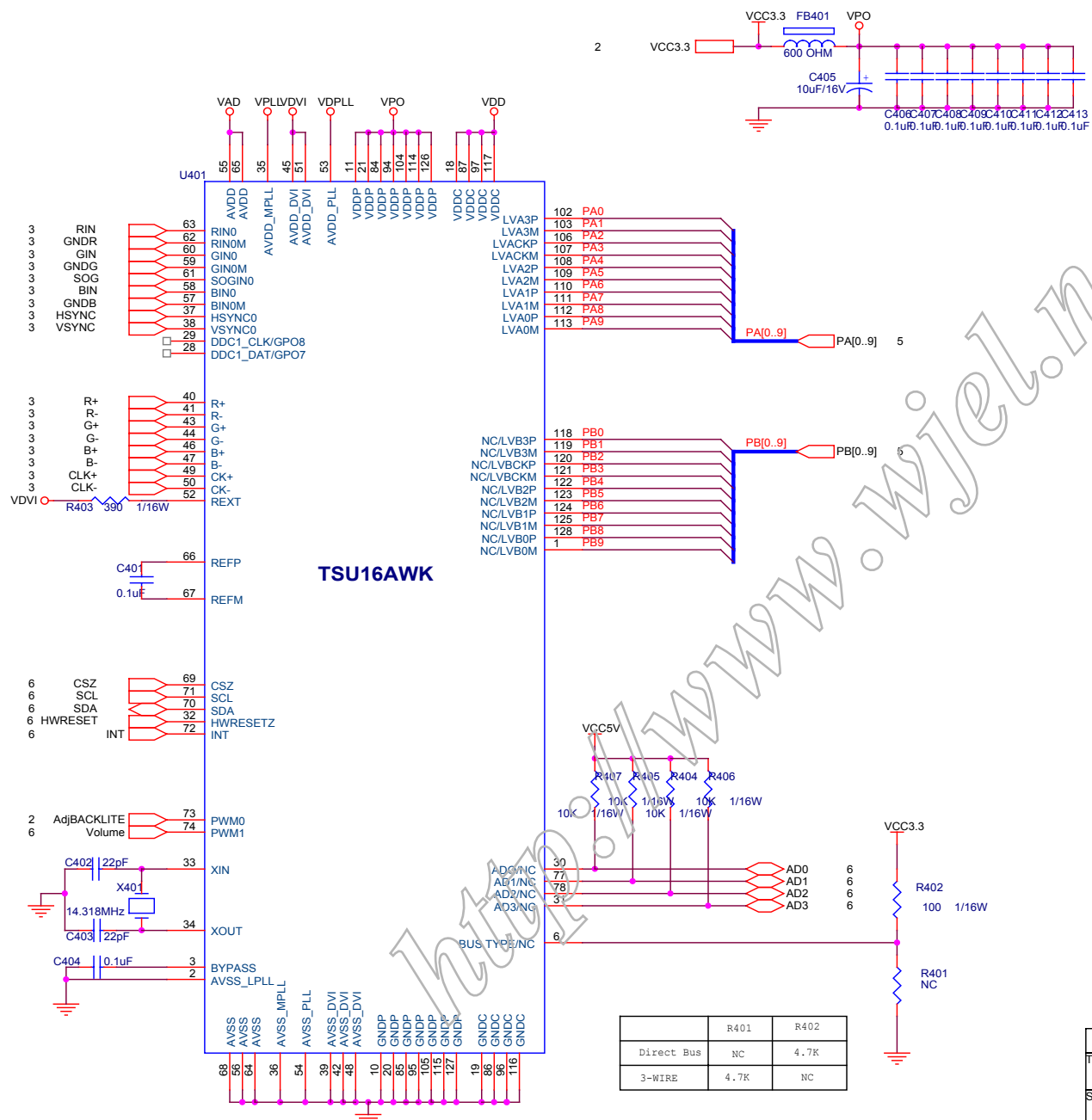

	R401	R402
Direct Bus	NC	4.7K
3-WIRE	4.7K	NC

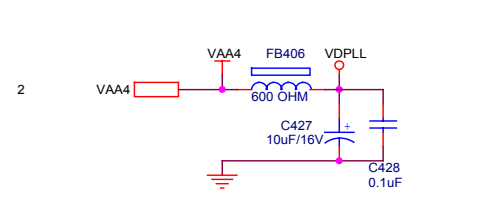
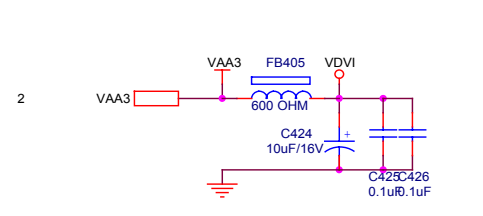
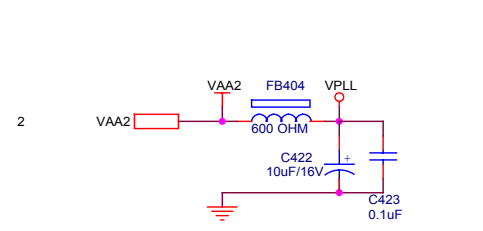
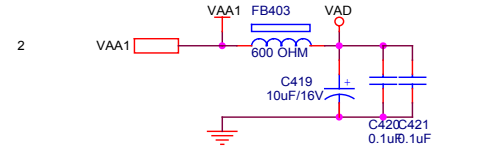
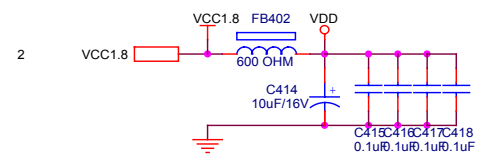

Title		
TSU16/56AK FOR MYSON 512 SWITCH		
Size	Document Number	Rev
B	SCALER	B
Date:	Wednesday, March 09, 2005	Sheet 4 of 6

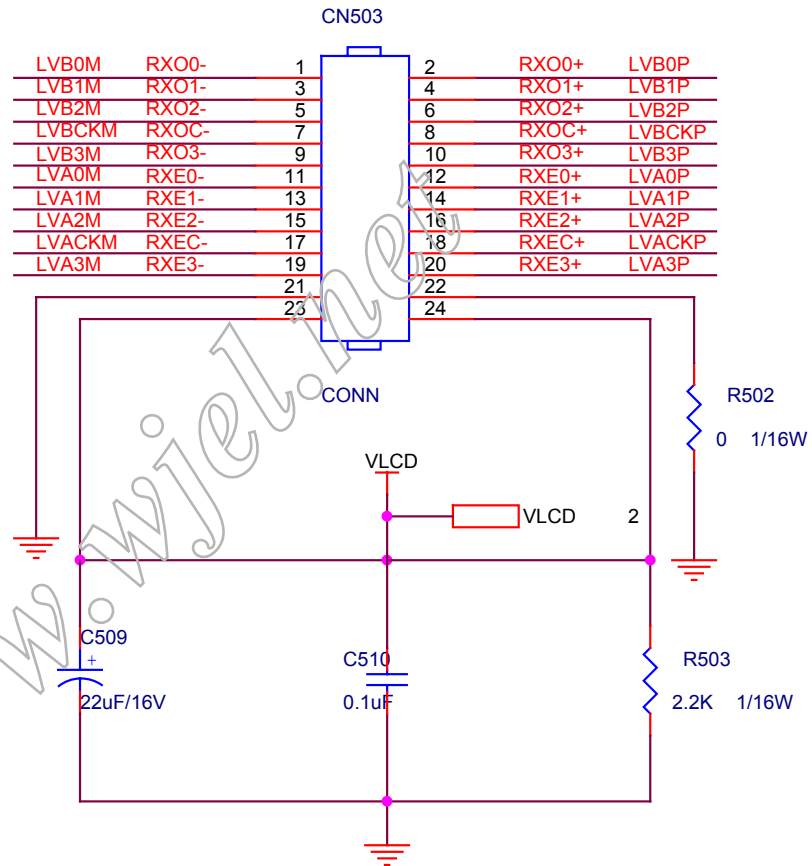
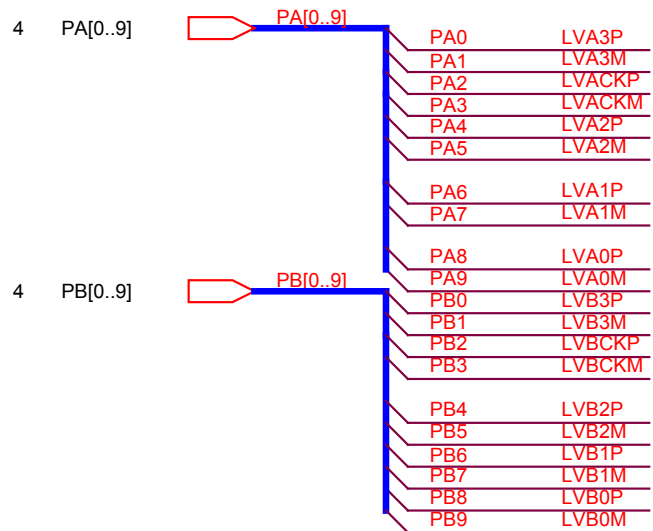

<http://www.wjw.net>

Title		
TSU16/56AK FOR MYSON 512 SWITCH		
Size	Document Number	Rev
A	PANEL INTERFACE	B
Date:	Wednesday, March 09, 2005	Sheet 5 of 6

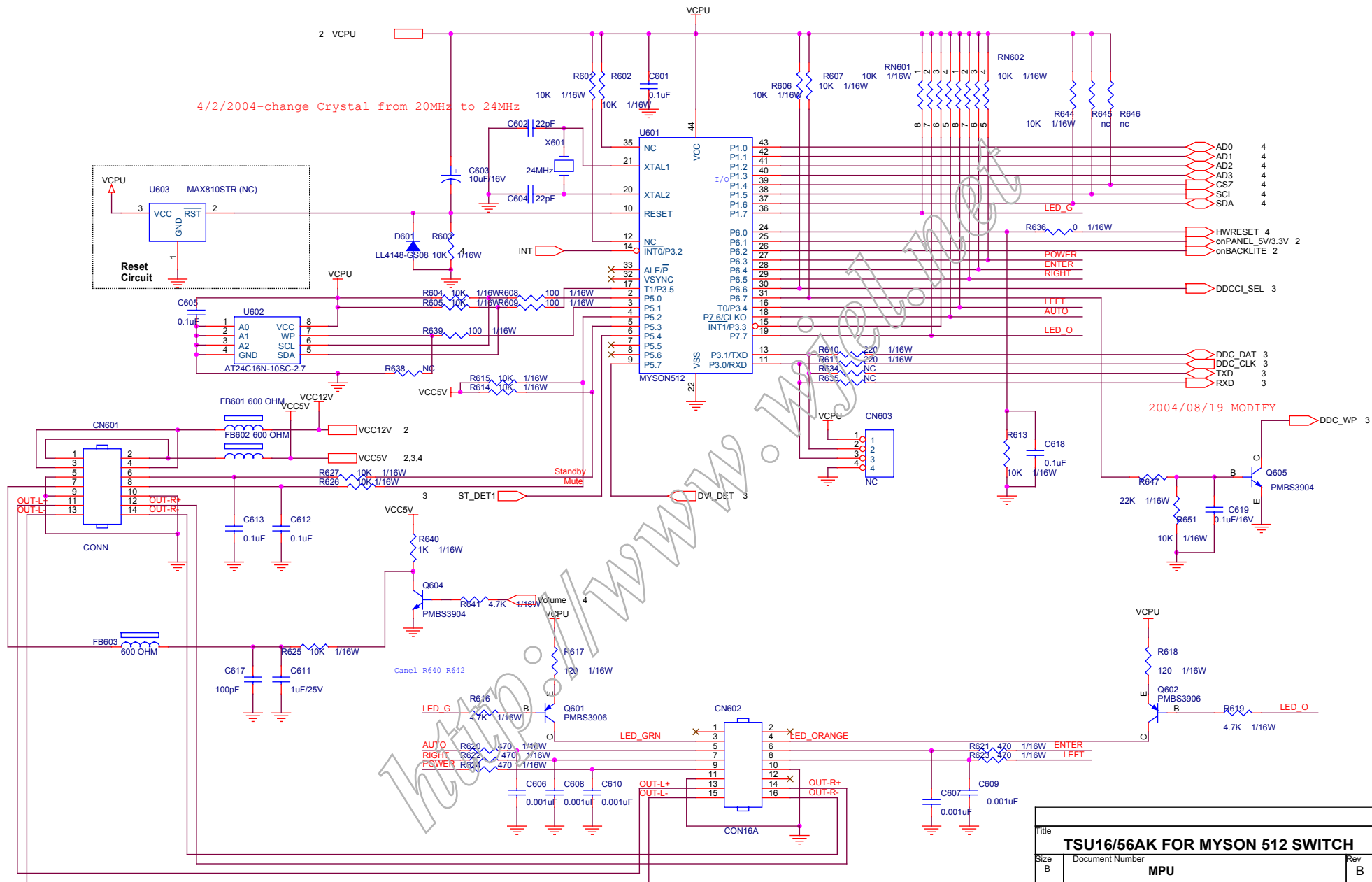

Title			TSU16/56AK FOR MYSON 512 SWITCH		
Size	Document Number		MPU		Rev
B					B
Date:	Wednesday, March 09, 2005	Sheet	6	of	6

6.2 Power Board

715G1349-3

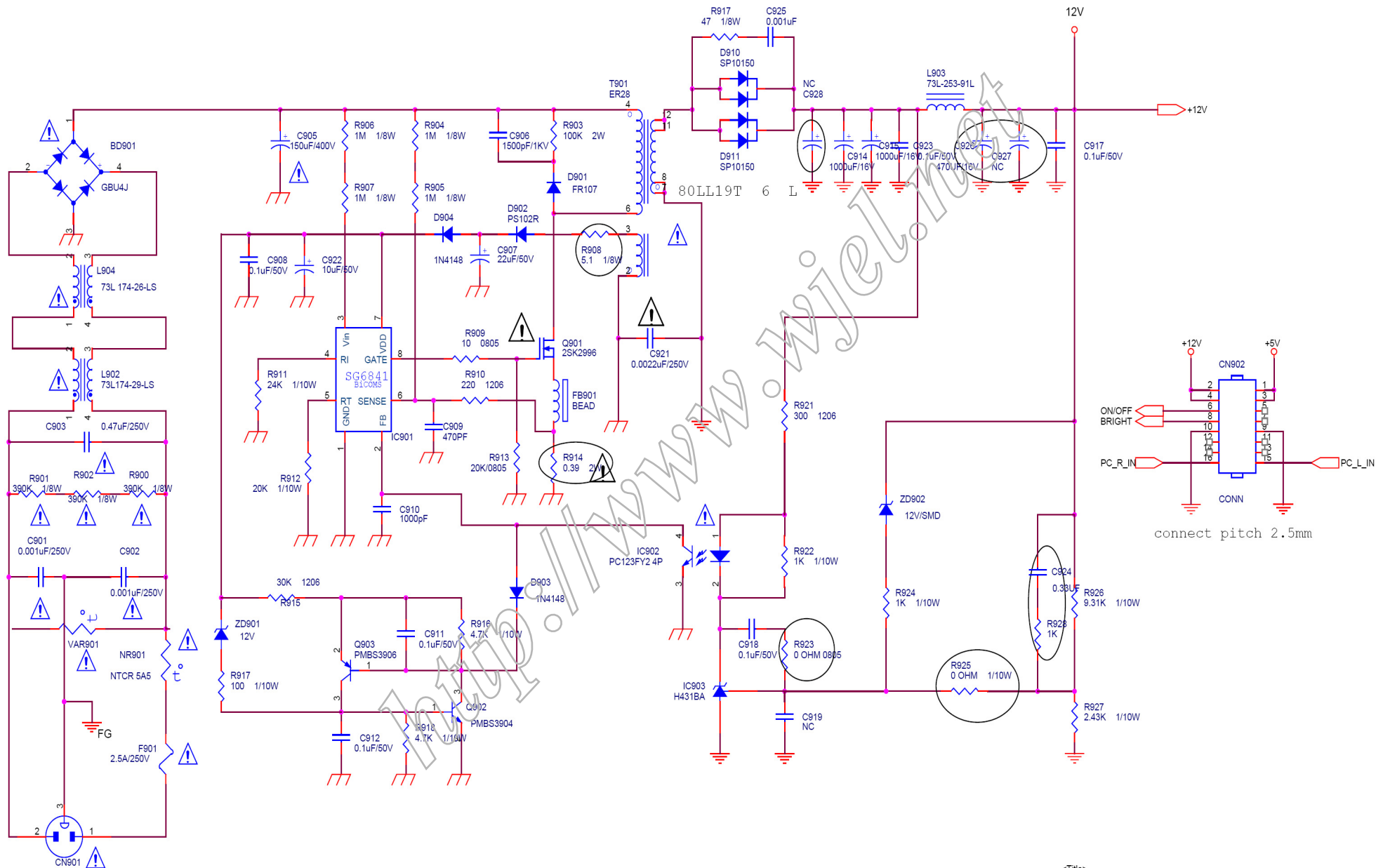

<Title>

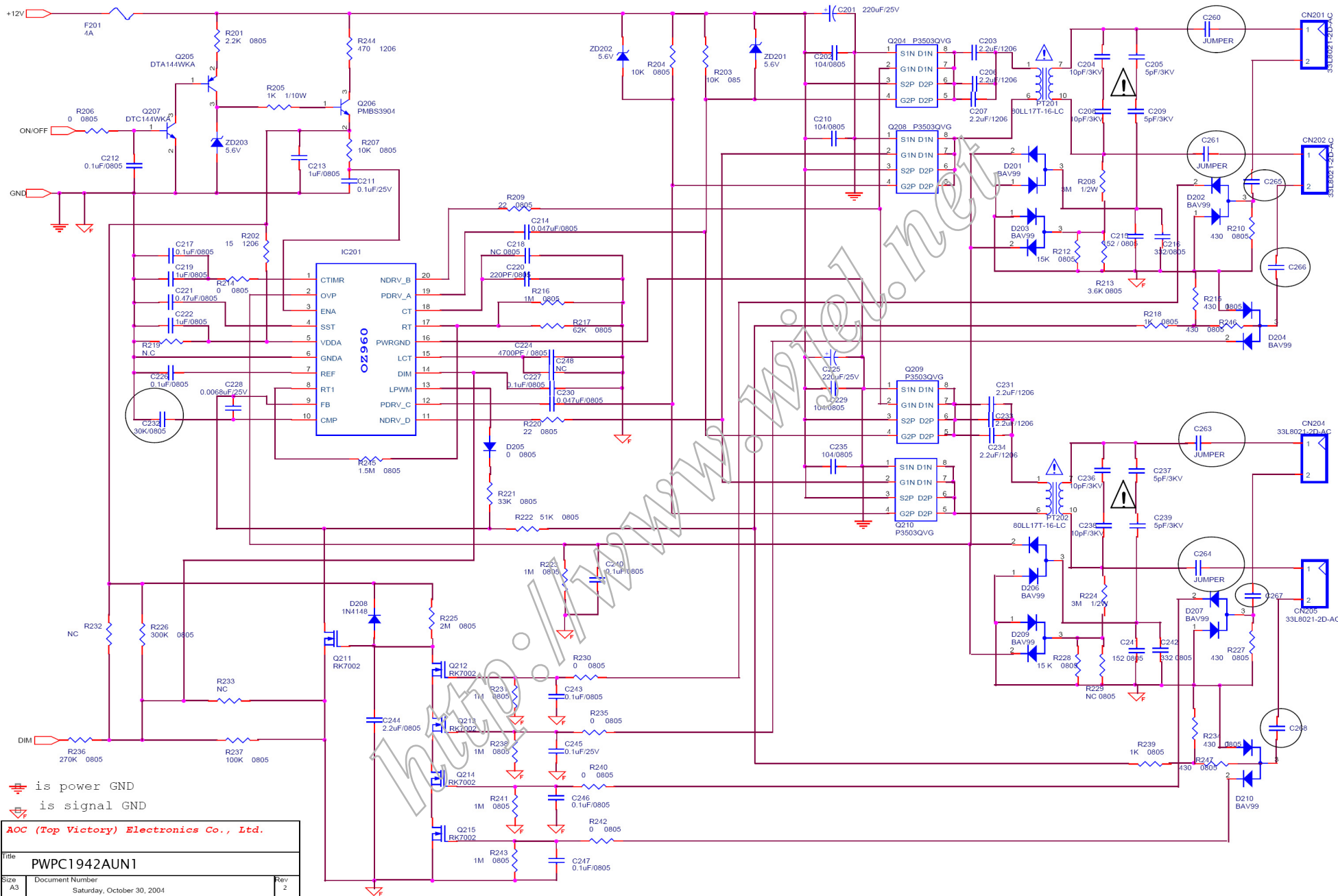

is power GND
 is signal GND

AOC (Top Victory) Electronics Co., Ltd.		
Title	PWPC1942AUN1	
Size	Document Number	Rev
A3	Saturday, October 30, 2004	2
Date:	Sheet	2 of 2

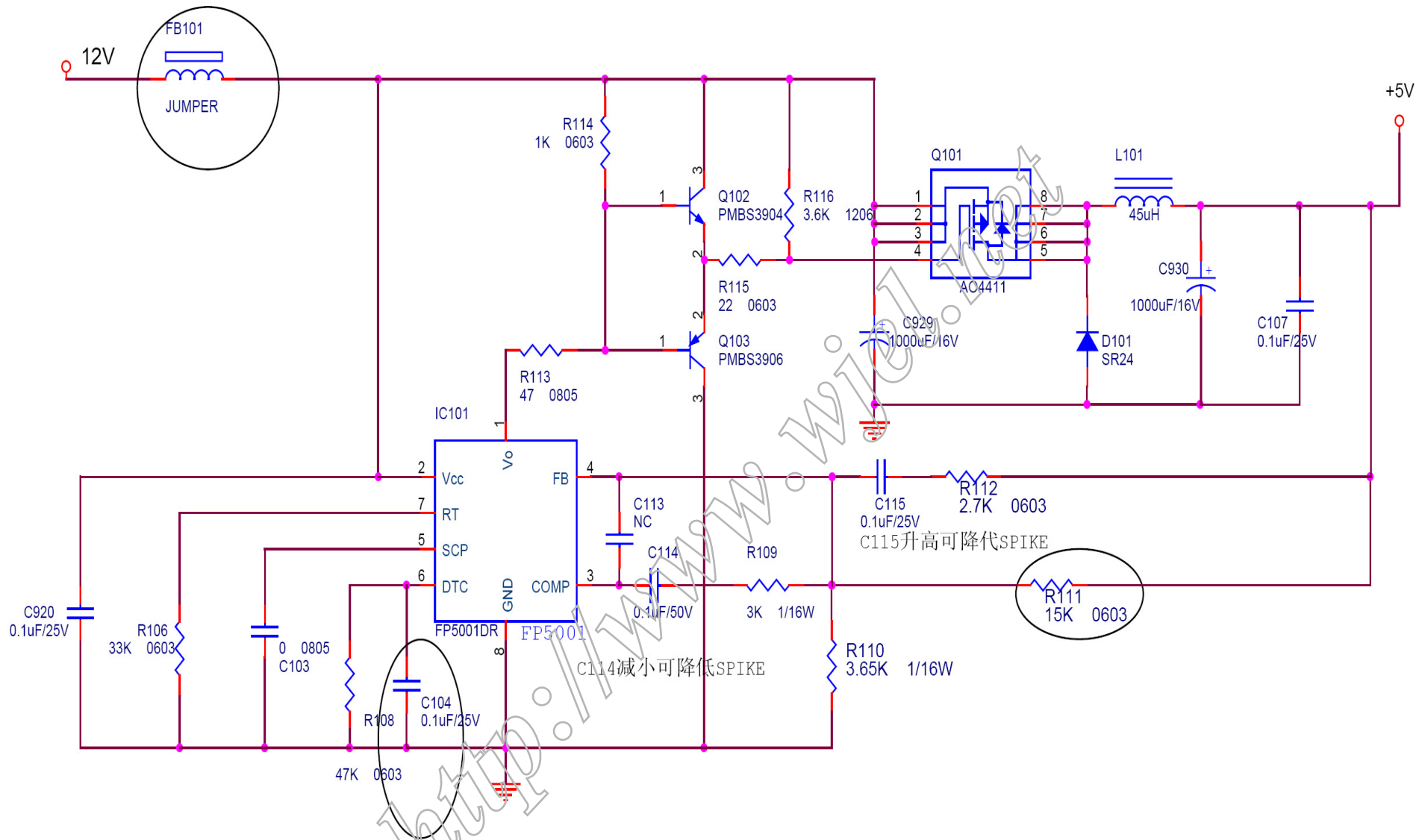

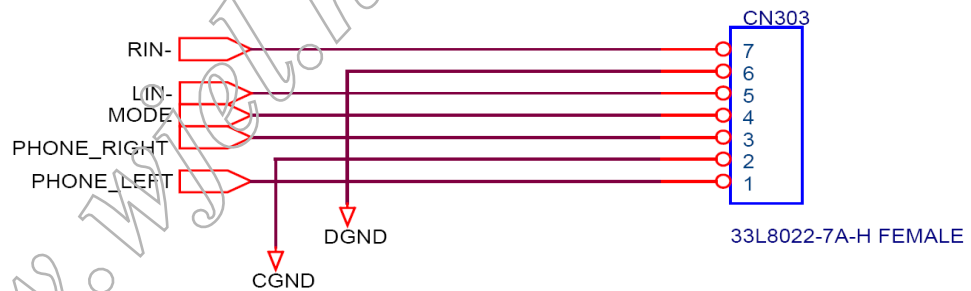
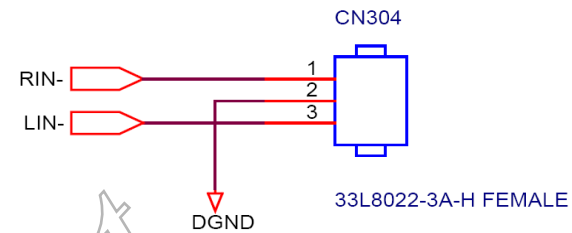
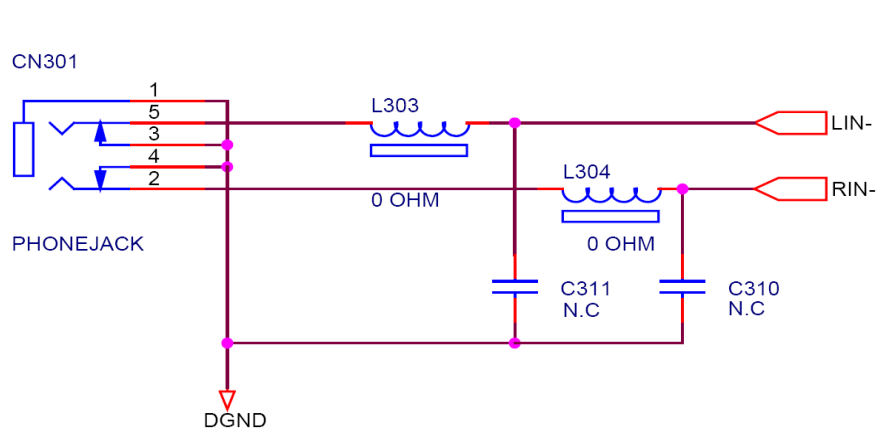

CN304 cm CN303 宁

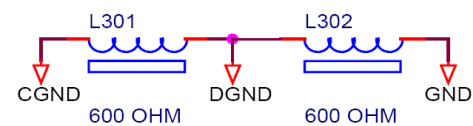
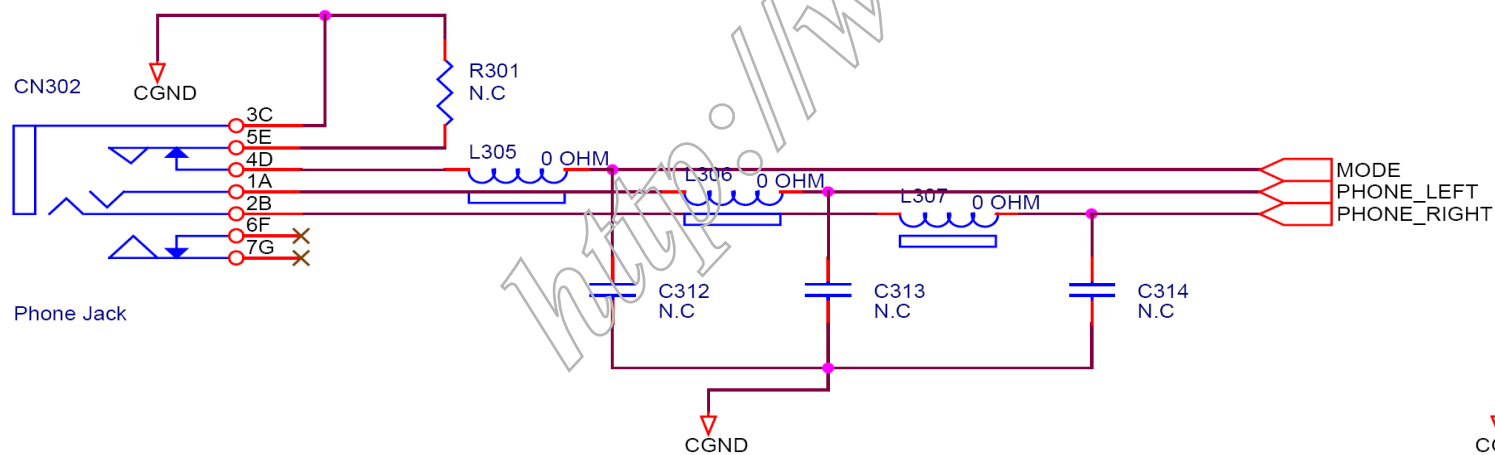

7. PCB Layout

7.1 Main Board

715G1423-3-512

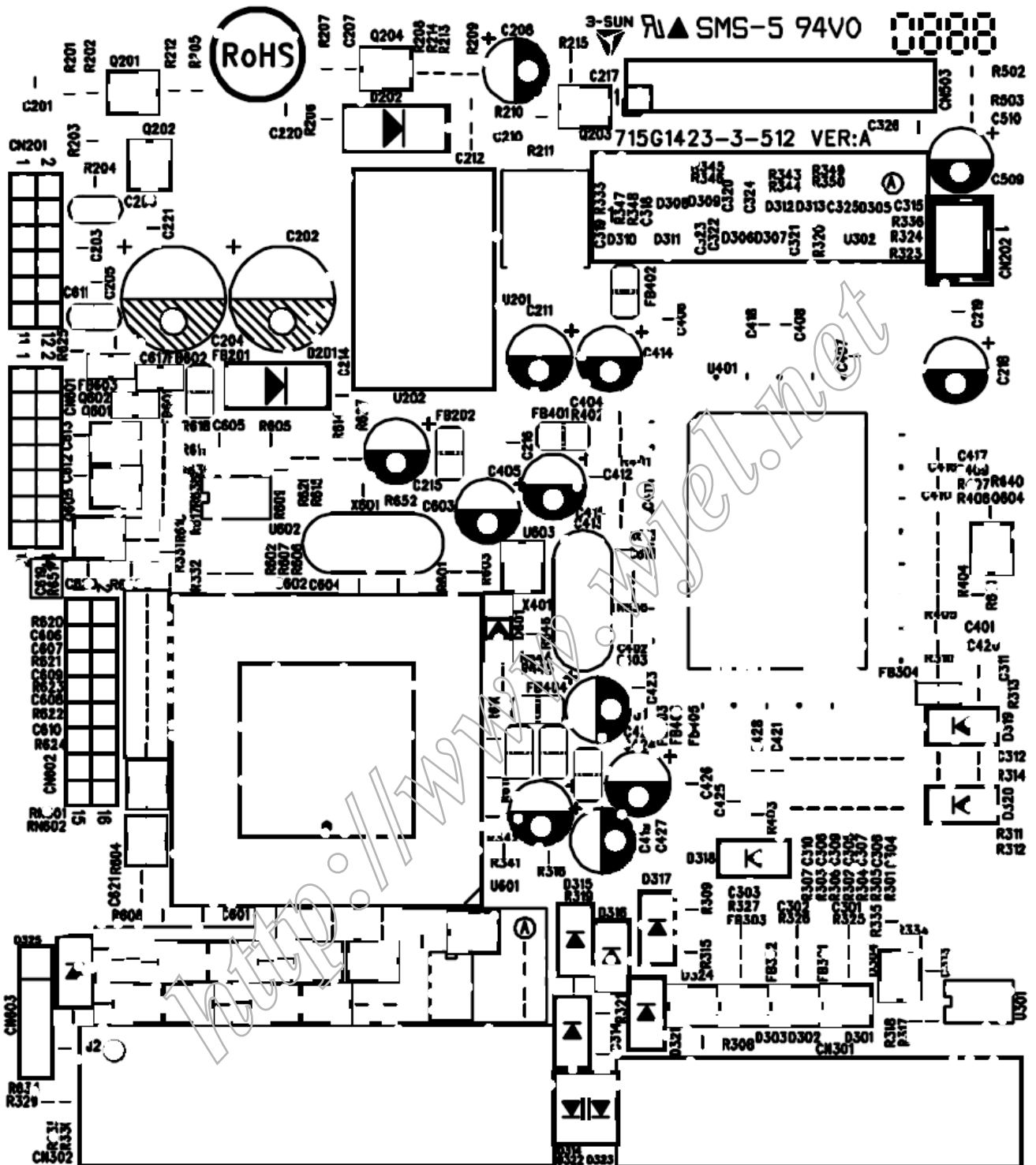

7.2 Power Board

715G1349-3

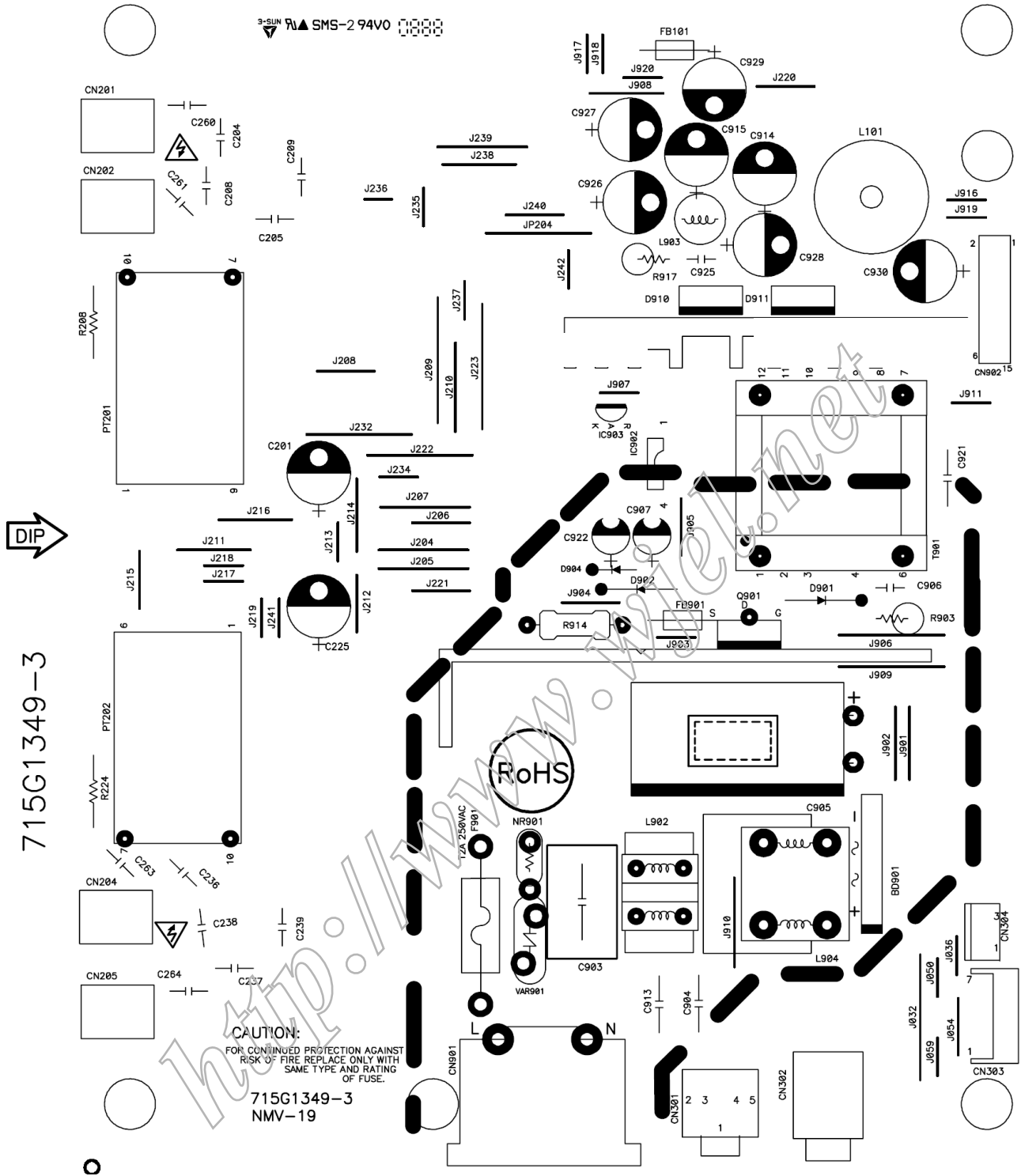

7.3 Key Board

715G1820-2

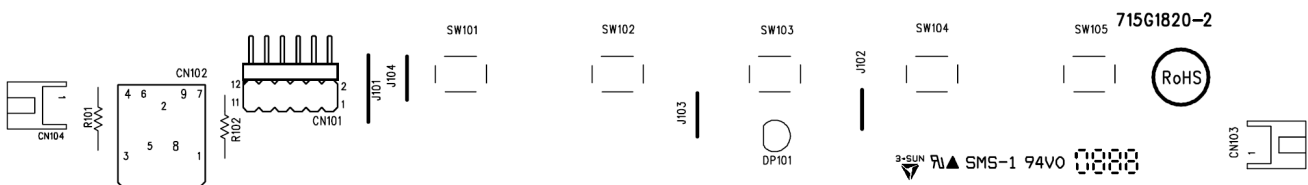

8. Maintainability

8.1 Equipments And Tools Requirement

1. Voltmeter.
2. Oscilloscope.
3. Pattern Generator.
4. DDC Tool with an IBM Compatible Computer.
5. Alignment Tool.
6. LCD Color Analyzer.
7. Service Manual.
8. User Manual.

<http://www.wjel.net>

8.2 Trouble Shooting

8.2.1 Main Board

No power

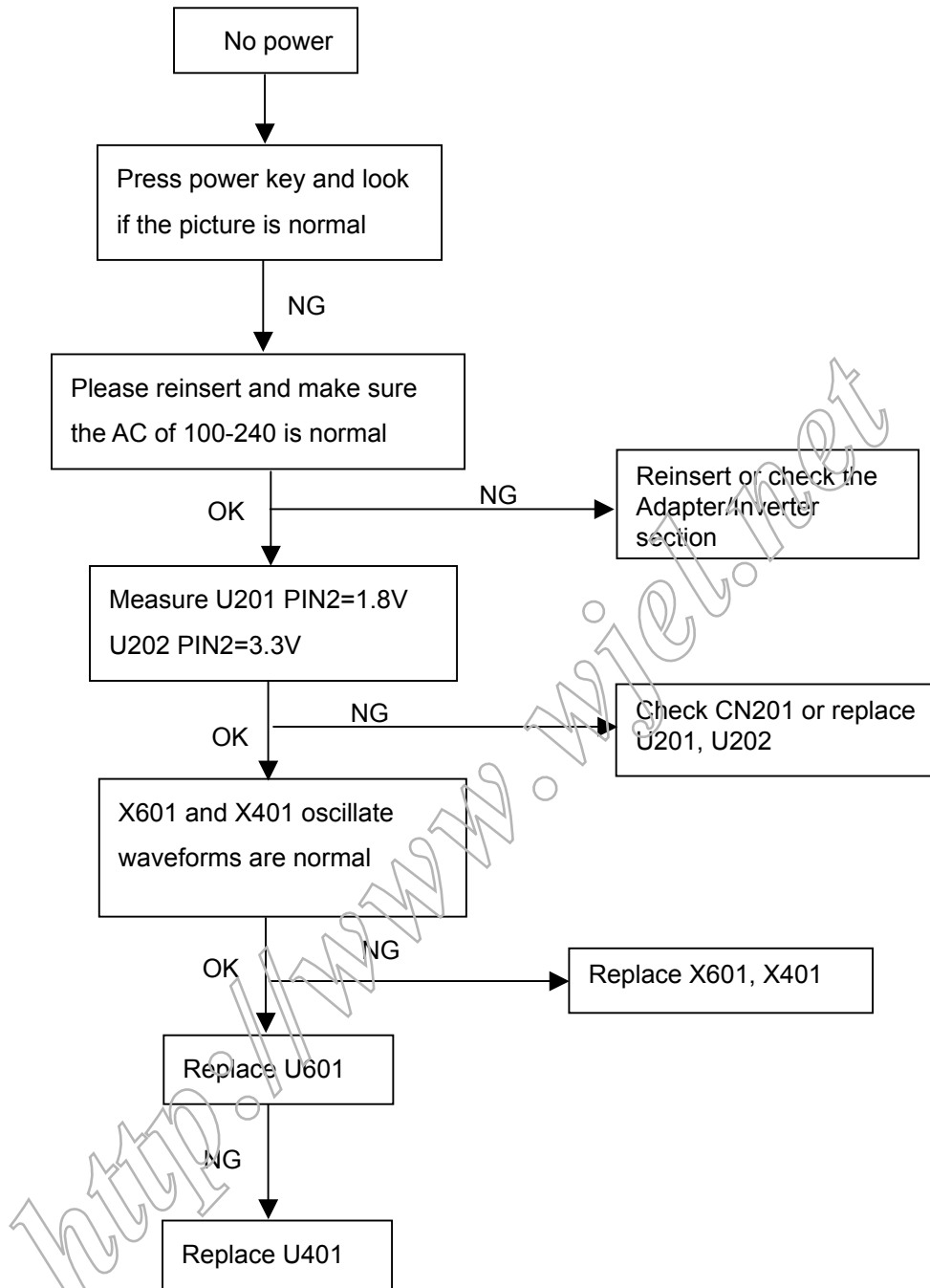

No picture (LED orange)

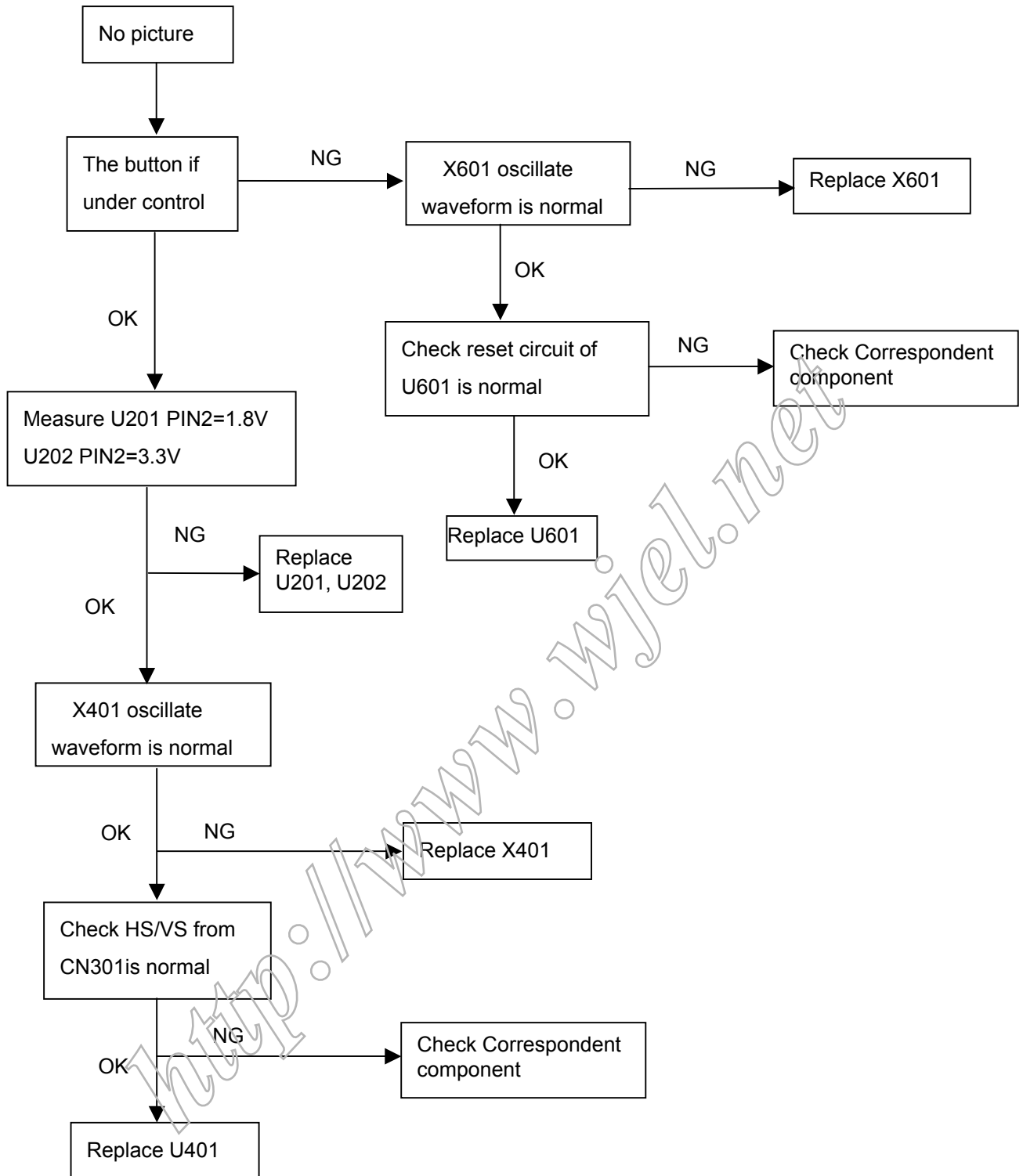

White screen

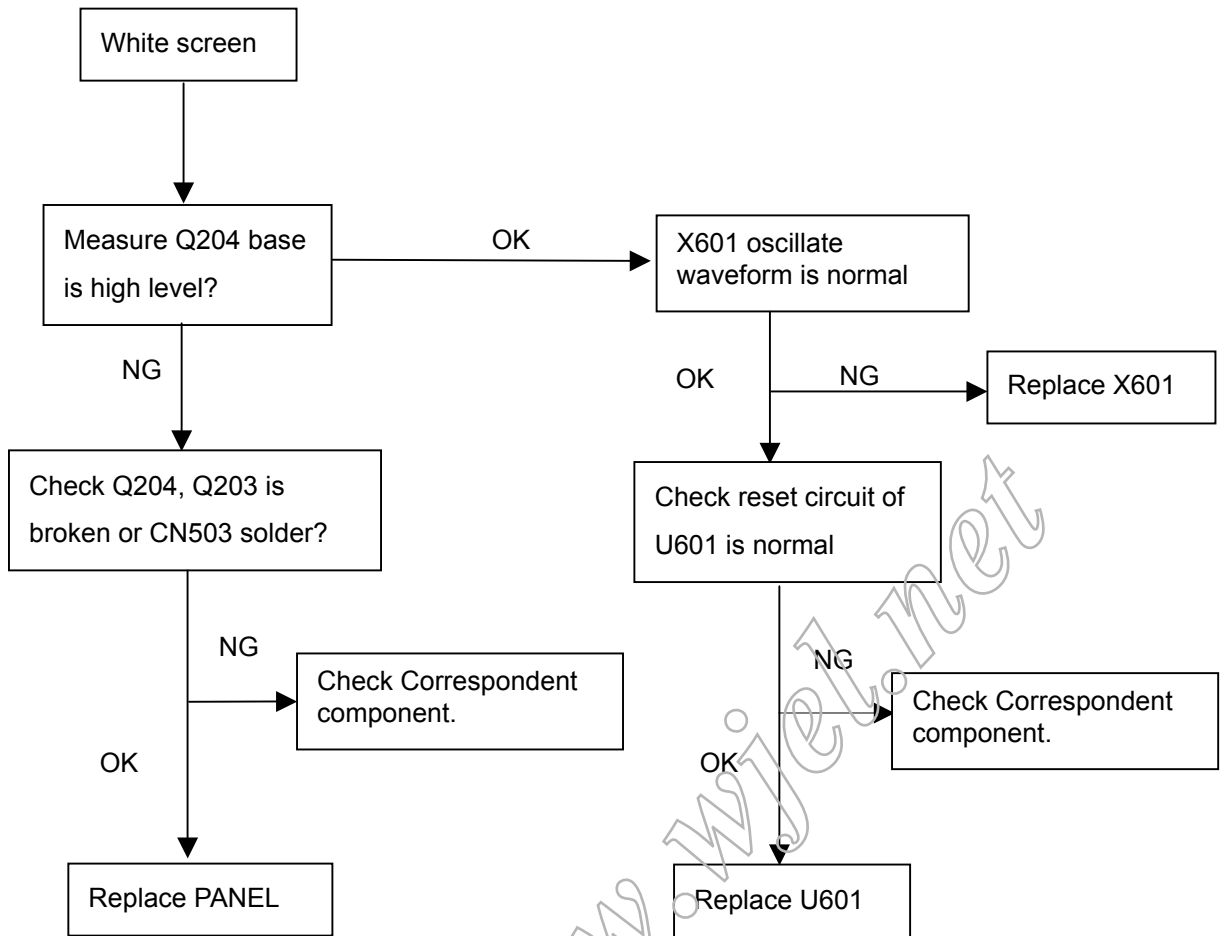

<http://www.wielmet.com>

8.2.2 Power/Inverter Board

1) No power

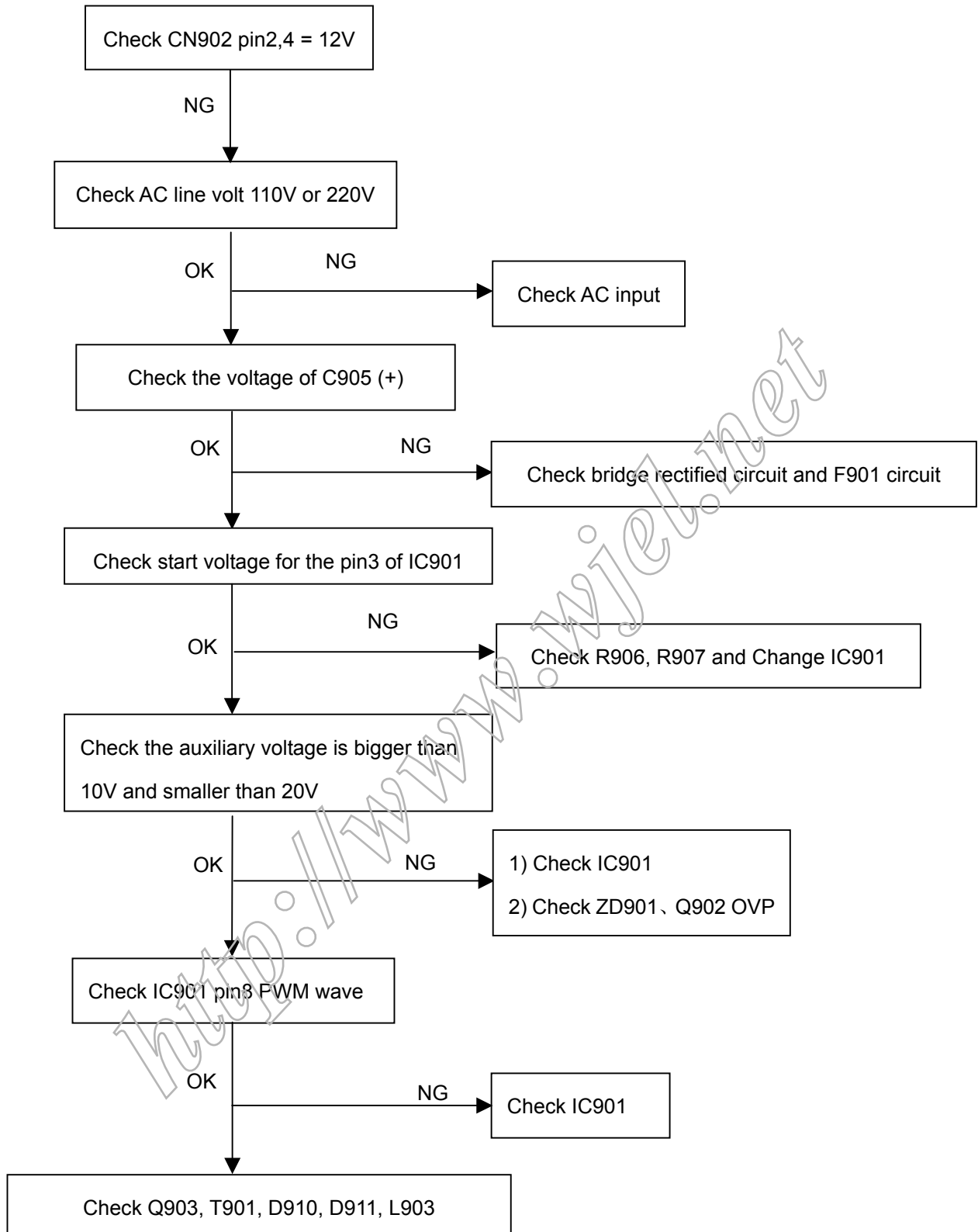

2.) W / LED, No Backlight

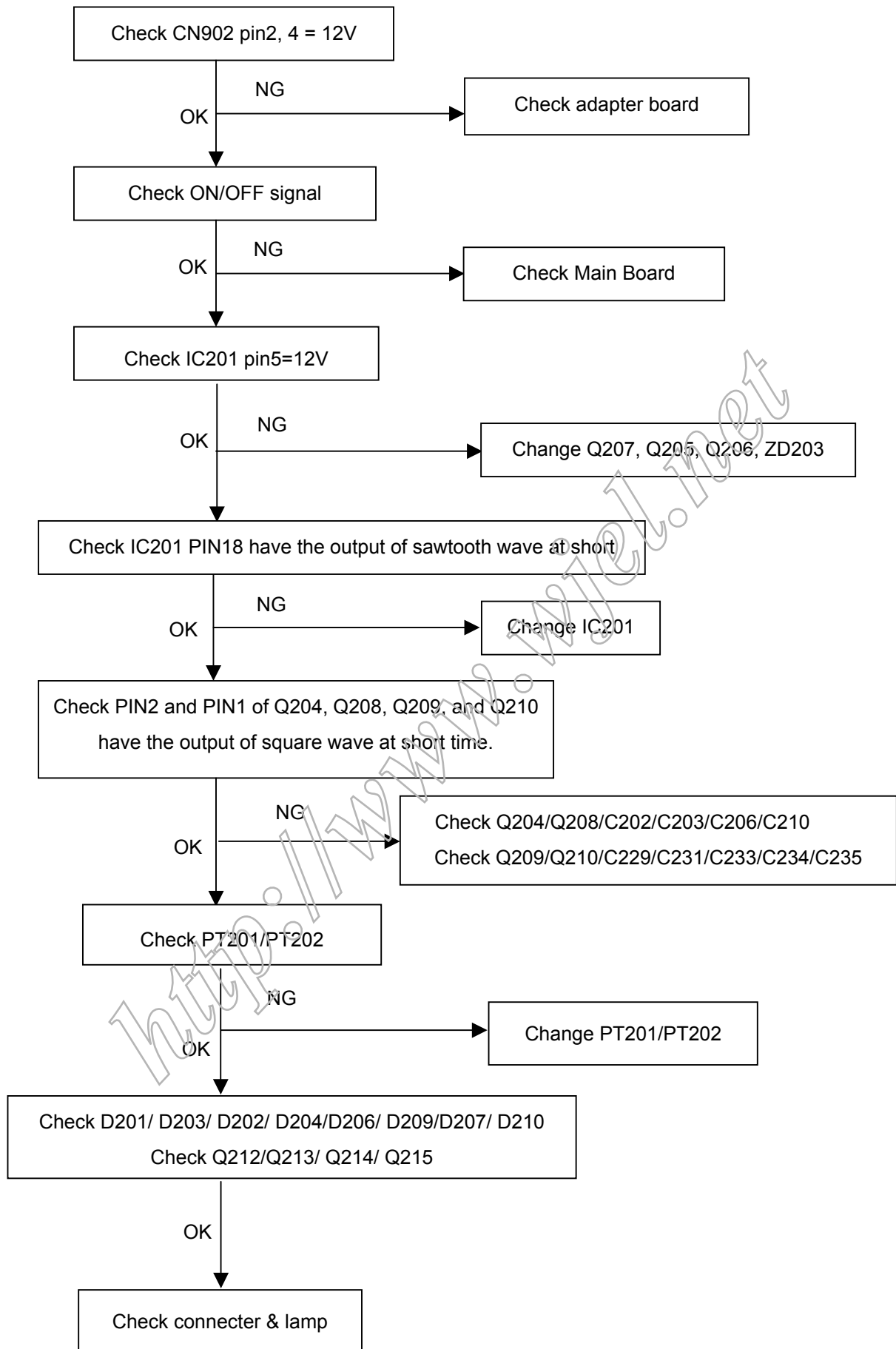

8.2.3 Keypad Board

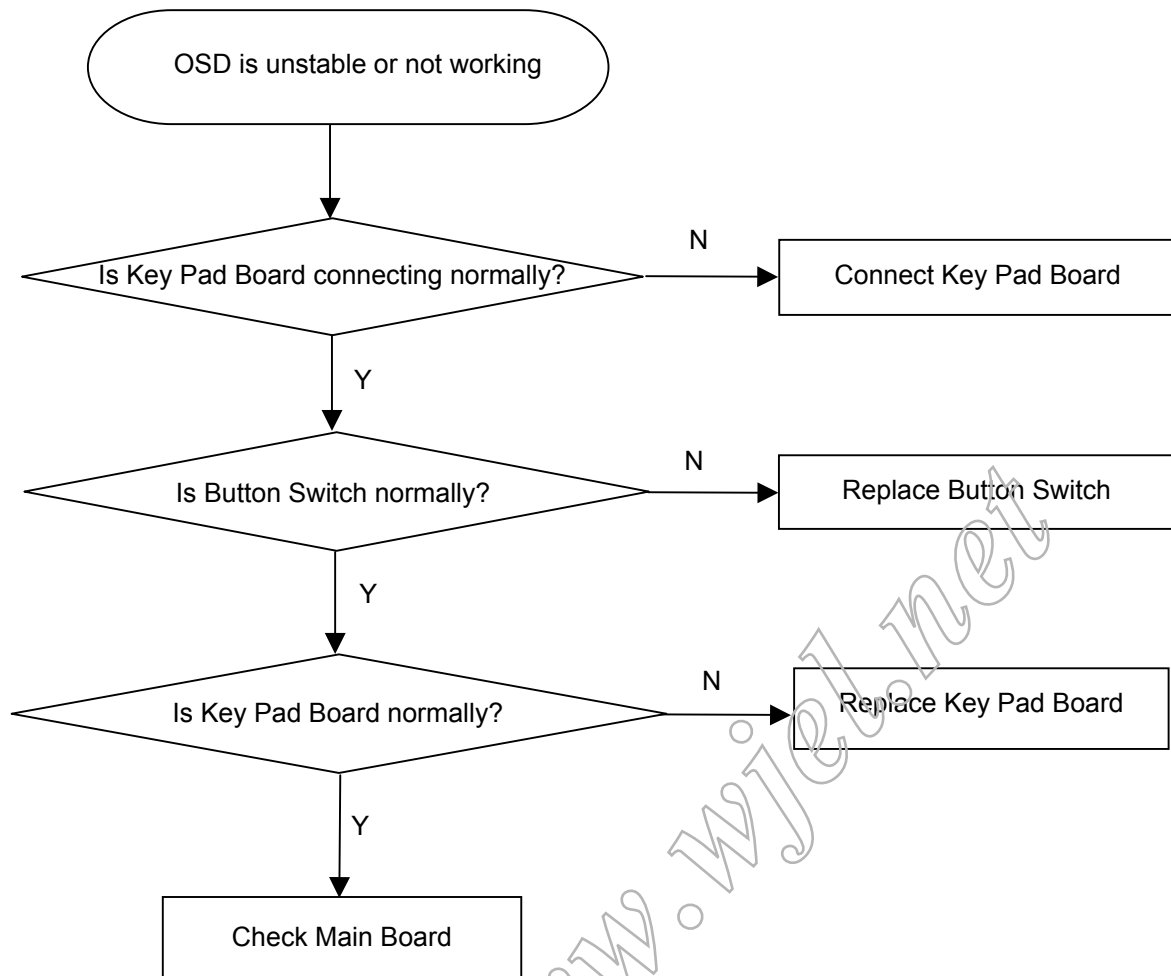

9. White- Balance, Luminance Adjustment

Approximately 30 minutes should be allowed for warm up before proceeding white balance adjustment.

Before started adjust white balance , please set the Chroma-7120 MEM Channel 9 to 9300 color, MEM Channel 10 to 7500 color, and MEM Channel 11 to 6500 color (our 9300 parameter is $x = 283 \pm 20, y = 297 \pm 20, Y = 180 \pm 10 \text{ cd/ m}^2$; 7500 parameter is $x = 299 \pm 20, y = 315 \pm 20, Y = 180 \pm 10 \text{ cd/ m}^2$; 6500 parameter is $x = 313 \pm 20, y = 329 \pm 20, Y = 180 \pm 10 \text{ cd/ m}^2$)

How to setting MEM channel you can reference to chroma 7120 user guide or simple use “ SC” key and “ NEXT” Key to modify xyY value and use “ID” key to modify the TEXT description Following is the procedure to do white-balance adjust .

2. Setting the color temp. you want

A. MEM.CHANNEL 3 (9300 color):

9300 color temp. parameter is $x = 283 \pm 20, y = 297 \pm 20, Y = 180 \pm 10 \text{ cd/ m}^2$

B. MEM.CHANNEL 4 (7500 color):

7500 color temp. parameter is $x = 299 \pm 20, y = 315 \pm 20, Y = 180 \pm 10 \text{ cd/ m}^2$

C. MEM.CHANNEL 5 (6500 color):

6500 color temp. parameter is $x = 313 \pm 20, y = 329 \pm 20, Y = 180 \pm 10 \text{ cd/ m}^2$

3. Into Factory mode of ASUS MM19D:

- ① Press the MENU button, pull out the power cord, and then plug the power cord. Then the factory OSD will be at the left top of the panel.
- ② Turn off the power, press MENU button and SPLENDID button, then press power button. Then the factory OSD will be at the left top of the panel.

4. Bias adjustment:

Set the **Contrast**  to 50; Adjust the **Brightness**  to 80.

5. Gain adjustment:

Move cursor to “-F-” and press MENU key

A. Adjust 9300 color-temperature

1. Switch the Chroma-7120 to **RGB-Mode** (with press “MODE” button)
2. Switch the MEM. Channel to Channel 3 (with up or down arrow on chroma 7120)
3. The LCD-indicator on chroma 7120 will show $x = 283 \pm 20, y = 297 \pm 20, Y = 180 \pm 10 \text{ cd/ m}^2$
4. Adjust the RED of color1 on factory window until chroma 7120 indicator reached the value R=100
5. Adjust the GREEN of color1 on factory window until chroma 7120 indicator reached the value G=100
6. Adjust the BLUE of color1 on factory window until chroma 7120 indicator reached the value B=100
7. Repeat above procedure (item 4,5,6) until chroma 7120 RGB value meet the tolerance = 100 ± 2

B. Adjust 7500 color-temperature

1. Switch the chroma-7120 to **RGB-Mode** (with press “MODE” button)
2. Switch the MEM.channel to Channel 4(with up or down arrow on chroma 7120)
3. The LCD-indicator on chroma 7120 will show $x = 299 \pm 20, y = 315 \pm 20, Y = 180 \pm 10 \text{ cd/ m}^2$
4. Adjust the RED of color3 on factory window until chroma 7120 indicator reached the value R=100
5. Adjust the GREEN of color3 on factory window until chroma 7120 indicator reached the value G=100

6. Adjust the BLUE of color3 on factory window until chroma 7120 indicator reached the value B=100
 7. Repeat above procedure (item 4,5,6) until chroma 7120 RGB value meet the tolerance = 100 ± 2
- C. Adjust 6500 color-temperature
1. Switch the chroma-7120 to **RGB-Mode** (with press "MODE" button)
 2. Switch the MEM.channel to Channel 5 (with up or down arrow on chroma 7120)
 3. The LCD-indicator on chroma 7120 will show $x = 313 \pm 20$, $y = 329 \pm 20$, $Y = 180 \pm 10 \text{ cd/ m}^2$
 4. Adjust the RED of color3 on factory window until chroma 7120 indicator reached the value R=100
 5. Adjust the GREEN of color3 on factory window until chroma 7120 indicator reached the value G=100
 6. Adjust the BLUE of color3 on factory window until chroma 7120 indicator reached the value B=100
 7. Repeat above procedure (item 4,5,6) until chroma 7120 RGB value meet the tolerance = 100 ± 2
- D. Turn the Power-button off to quit from factory mode.

<http://www.wjel.net>

10. EDID Content

	00	01	02	03	04	05	06	07	08	09	10	11	12	13	14	15
0:	00	FF	FF	FF	FF	FF	FF	00	04	69	D3	19	79	C2	00	00
16:	06	10	01	03	68	26	1E	78	2A	C0	F5	A3	57	4A	9C	23
32:	11	4F	54	BF	EF	00	81	80	01	01	01	01	01	01	01	01
48:	01	01	01	01	01	01	BC	34	00	98	51	00	2A	40	10	90
64:	13	00	54	0E	11	00	00	1E	00	00	00	FF	00	32	33	31
80:	36	35	34	39	37	38	35	0A	20	20	00	00	00	FD	00	37
96:	4B	1E	53	0E	00	0A	20	20	20	20	20	20	00	00	00	FC
112:	00	41	53	55	53	20	4D	4D	31	39	44	0A	20	20	00	4D

<http://www.wjel.net>

11. BOM List

T980KH4DTAUSNP

Location	Part No. for TPV	Description	Quantity
	007G 5 L 65	COMPOUND PALLET	1.000
	015G6207 L 3	PANEL BRACKET	1.000
	015G6207 R 3	PANEL BRACKET	1.000
	040G 152509	RECYCLE LABEL	1.000
	040G 152512	RECYCLE LABEL	1.000
	040G 457834 4A GP	S/N LABEL FOR ID	1.000
	040G 457842 2B	PALLET LABEL	1.000
	040G 58162435A	LABEL	2.000
	040G 581680 1A	WARRANTY LABEL	2.000
	040G 581680 3A	SPLENDID LABEL	1.000
	040G 581680 4A	TRY ME LABEL	1.000
	040G 58169016A	TCO'03 LABEL	1.000
	040G 582680 1A	CARTON LABEL	1.000
	040G 582680 3A	PALLET LABEL	1.000
	040G 582680 4A	CARTON LABEL	2.000
	044G3928 1	EPS	1.000
	044G3928 2	EPS	1.000
	044G6000 4 6B	PAPER BOARD	1.000
	044G6002120106	PAPER BOARD	1.000
	044G6002CP202A	PAPER CAP	1.000
	044G9003202	CORNER PAPER	1.000
	045G 88606	PE BAG FOR BASE	1.000
	045G 88626 1	PE BAG FOR MONITOR	1.000
	050G 600 2	HANDLE1	1.000
	050G 600 3	HANDLE2	1.000
	052G 1185	MIDDLE TAPE FOR CARTON	65.000
	052G 1185 49	ASUS TAPE	25.000
	052G 1186	SMALL TAPE	8.000
	052G 1209 A	200MINIUM TAPE	2.000
	052G 1211513	AL TAPE	2.000
	052G6020 5	PROTECT FILM	1.000
	052G6025 11989	MYLAR	1.000
	085G6119 A 4	SHIELD	1.000
	089G 718HAA D2	SIGNAL CABLE	1.000
	089G402A18N LS	POWER CORD	1.000

	095G 900590	WIRE HARNESS	1.000
	095G8014 16599	WIRE HARNESS	1.000
	0M1G 330 5128	SREW	4.000
	0M1G 330 5128	SREW	4.000
	0M1G1140 6128	SCREW 4X6	1.000
	0M1G1730 6128	SCREW M3x6	7.000
	0M1G3030 6 47	SCREW	4.000
	0Q1G 330 6128	SCREW	4.000
	0Q1G 330 8 47	SCREW 3X8mm	1.000
	705GQ9K0F34003	19" LCD BEZEL ASS'Y	1.000
	705GQ9K0P34001	19" LCD STAND-BASE ASS'Y	1.000
	705L980KB34189	19" LCD COVER ASS'Y	1.000
E750L	750GLH9013A 11	HSD 19" A10 PANEL	1.000
	AM1G1740 12 47	SCREW	4.000
	CBPC980KH4USP	CONVERSION BOARD	1.000
	KEPC980KUSNP	KEY BOARD	1.000
	PWPC1942HSU4P	19" LCD POWER BOARD	1.000
	Q40G 19N680 6A	RATING LABEL	1.000
	Q44G3910680 3A	CARTON	1.000
	S95G801830634	LVDS	1.000
	041G780061537A	TCO'03 CARD	1.000
	041G7800680 9A	Warranty-CT	1.000
	045G 76 28 RN	PE BAG FO MANUAL/BASE	1.000
	045G 76 28V13	PE BAG FOR MANUAL	1.000
	Q41G7800680 8A	QSG for east	1.000
	Q70G1900680 1A	CD MANUAL	1.000
	033G4891 1	LENS	1.000
	Q33G6433 XJ 1L	KEY PAD	1.000
	Q34G6398 XJA2B	BEZEL	1.000
	012G 394 3	RUBBER FOOT	4.000
	034G1546 GM B	STAND	1.000
	037G 510 2	HINGE	1.000
	0Q1G1040 10128	TAP 4X8 FOR SP	3.000
	Q33G4695 GM 1C	CLAMP	1.000
	Q34G6400 XJ 1B 20	BASE DOWN	1.000
	015G6206 1	HINGE BRACKET	1.000
	034G6202 GM20B	REAR COVER	1.000
	052G6025 11925	MYLAR	1.000

	0Q1G 140 8128	SCREW	6.000
CN201	033G8027 12	WAFER 2*6P 2.0MM R/A	1.000
CN602	033G8027 16	WAFER 16PIN 2.0mm DIP	1.000
CN503	033G802724B H	WAFER	1.000
	040G 45762412B	CBPC LABEL	1.000
C204	067G215B221 4H	LOW E.S.R 220UF +-20% 25V	1.000
C202	067G215B221 4H	LOW E.S.R 220UF +-20% 25V	1.000
CN301	088G 35315F H	D-SUB 15PIN	1.000
X601	093G 22 45 H	24MHZ/30PF/49US	1.000
X401	093G 22 53	CRYSTAL 14.318MHzHC-49US	1.000
	AIC980KH4USP	MAIN BOARD	1.000
CN101	033G8027 12 H	PIN HEADER 2*6 R/A	1.000
SW105	077G 600 1GCJ	TACT SWITCH TSPB-2 -NP	1.000
SW104	077G 600 1GCJ	TACT SWITCH TSPB-2 -NP	1.000
SW103	077G 600 1GCJ	TACT SWITCH TSPB-2 -NP	1.000
SW102	077G 600 1GCJ	TACT SWITCH TSPB-2 -NP	1.000
SW101	077G 600 1GCJ	TACT SWITCH TSPB-2 -NP	1.000
DP101	081G 12 1N GP	LED	1.000
	AIK980KUSNSMTP	KEY BOARD FOR SMT	1.000
CN205	033G8021 2D U	3.5mm WAFER	1.000
CN204	033G8021 2D U	3.5mm WAFER	1.000
CN202	033G8021 2D U	3.5mm WAFER	1.000
CN201	033G8021 2D U	3.5mm WAFER	1.000
	040G 45762420A	LABEL 25x6mm	2.000
IC902	056G 139 3A	PC123Y22FZOF	1.000
NR901	061G 58050 WT	NTC 5 OHM 5A	1.000
R917	061G 29747052T	47 OHM 1/2W	1.000
R914	061G 152M398 64	0.39 OHM 2W	1.000
C236	065G 3J1006ET	10PF,J,3KV,SL	1.000
C208	065G 3J1006ET	10PF,J,3KV,SL	1.000
C204	065G 3J1006ET	10PF,J,3KV,SL	1.000
C238	065G 3J1006ET	10PF,J,3KV,SL	1.000
C205	065G 3J5096ET	5PF 5% SL 3KV	1.000
C209	065G 3J5096ET	5PF 5% SL 3KV	1.000
C237	065G 3J5096ET	5PF 5% SL 3KV	1.000
C239	065G 3J5096ET	5PF 5% SL 3KV	1.000
C913	065G306M1022BP	1000PF Y1.CAP	1.000
C904	065G306M1022BP	1000PF Y1.CAP	1.000

C921	065G306M2222BP	2200PF +-20% 400VAC	1.000
C926	067G215D471 4K	ED 470UF 25V	1.000
C930	067G215L102 3R	LOW E.S.R 1000UF +/-20% 16V	1.000
C929	067G215L102 3R	LOW E.S.R 1000UF +/-20% 16V	1.000
C915	067G215L102 3R	LOW E.S.R 1000UF +/-20% 16V	1.000
C914	067G215L102 3R	LOW E.S.R 1000UF +/-20% 16V	1.000
C225	067G215L102 3R	LOW E.S.R 1000UF +/-20% 16V	1.000
C201	067G215L102 3R	LOW E.S.R 1000UF +/-20% 16V	1.000
C905	067G215S10115K	100UF 450V	1.000
L903	073G 253 91 T	CHOKE	1.000
L101	073G 253152 T	CHOKE COIL TDK LSHAOO3C-002	1.000
L904	073L 174 26T1G	LINE LILT 0.45MM	1.000
L902	073L 174 53 LG GP	CHOKE	1.000
PT202	080LL17T 16DNG	TRANSFORMER	1.000
PT201	080LL17T 16DNG	TRANSFORMER	1.000
T901	080LL19T 6 LG	X'FMR	1.000
F901	084G 7H200 SL	250V/2A LIHEL FUSE	1.000
BD901	093G 50460 16	U4KB80R	1.000
CN902	095G8021 12518	WIRE HARNESS	1.000
	705L 560 61 06	R903 ASS'Y	1.000
	705L 780 57 51	Q901 ASS'Y	1.000
	705L 980 87 05	CN901 ASS'Y	1.000
	705L 980 93 04	D910/D911 ASS'Y	1.000
	PW1942HSU4SMTP	19" LCD POWER BOARD FOR SMT	1.000
	033F 206 24	DF11-24DS-2C	1.000
	033F 303 30TD1	TD00-30H P2407P30	1.000
	033F206T 24	DF11-2428SCF	24.000
	033F303T TD1	TD00-T 2407PS-00	24.000
	040G 457624 1B	LABEL-CPU	1.000
U401	056G 562104	TSU16AWK-LF	1.000
U202	056G 563 7	AIC1084-33PM	1.000
U201	056G 563 31	AI1117D-1.8-EI	1.000
U603	056G 643 5A	MAX810 STRG	1.000
U601	056G1125170 X	W79E632 BY WINBOND	1.000
U301	056G1133 34	M24C02-WMN6TP	1.000
U602	056G1133 56	M24C16-WMN6TP	1.000
Q605	057G 417 4	PMBS3904/PHILIPS-SMT(04)	1.000
Q204	057G 417 4	PMBS3904/PHILIPS-SMT(04)	1.000

Q202	057G 417 4	PMBS3904/PHILIPS-SMT(04)	1.000
Q201	057G 417 4	PMBS3904/PHILIPS-SMT(04)	1.000
Q602	057G 417 6	PMBS3906/PHILIPS-SMT(06)	1.000
Q601	057G 417 6	PMBS3906/PHILIPS-SMT(06)	1.000
Q203	057G 763 1	A03401 SOT23 BY AOS(A1)	1.000
RN602	061L 125103 8	CHIP AR 8P4R 10KOHM +-5% 1/16W	1.000
RN601	061L 125103 8	CHIP AR 8P4R 10KOHM +-5% 1/16W	1.000
R204	061L0603000	RST SM 0603 JUMP MAX 0R05 R	1.000
R502	061L0603000	RST SM 0603 JUMP MAX 0R05 R	1.000
R209	061L0603000	RST SM 0603 JUMP MAX 0R05 R	1.000
FB303	061L0603000	RST SM 0603 JUMP MAX 0R05 R	1.000
FB302	061L0603000	RST SM 0603 JUMP MAX 0R05 R	1.000
FB301	061L0603000	RST SM 0603 JUMP MAX 0R05 R	1.000
R307	061L0603101	CHIPR 100 OHM +-5% 1/16W	1.000
R608	061L0603101	CHIPR 100 OHM +-5% 1/16W	1.000
R609	061L0603101	CHIPR 100 OHM +-5% 1/16W	1.000
R315	061L0603101	CHIPR 100 OHM +-5% 1/16W	1.000
R312	061L0603101	CHIPR 100 OHM +-5% 1/16W	1.000
R309	061L0603101	CHIPR 100 OHM +-5% 1/16W	1.000
R316	061L0603101	CHIPR 100 OHM +-5% 1/16W	1.000
R341	061L0603101	CHIPR 100 OHM +-5% 1/16W	1.000
R342	061L0603101	CHIPR 100 OHM +-5% 1/16W	1.000
R402	061L0603101	CHIPR 100 OHM +-5% 1/16W	1.000
R639	061L0603101	CHIPR 100 OHM +-5% 1/16W	1.000
R636	061L0603101	CHIPR 100 OHM +-5% 1/16W	1.000
R306	061L0603101	CHIPR 100 OHM +-5% 1/16W	1.000
R305	061L0603101	CHIPR 100 OHM +-5% 1/16W	1.000
R624	061L0603102	CHIPR 1K OHM +-5% 1/16W	1.000
R311	061L0603102	CHIPR 1K OHM +-5% 1/16W	1.000
R310	061L0603102	CHIPR 1K OHM +-5% 1/16W	1.000
R203	061L0603102	CHIPR 1K OHM +-5% 1/16W	1.000
R404	061L0603103	CHIPR 10K OHM +-5% 1/16W	1.000
R405	061L0603103	CHIPR 10K OHM +-5% 1/16W	1.000
R406	061L0603103	CHIPR 10K OHM +-5% 1/16W	1.000
R407	061L0603103	CHIPR 10K OHM +-5% 1/16W	1.000
R601	061L0603103	CHIPR 10K OHM +-5% 1/16W	1.000
R602	061L0603103	CHIPR 10K OHM +-5% 1/16W	1.000
R604	061L0603103	CHIPR 10K OHM +-5% 1/16W	1.000

R605	061L0603103	CHIPR 10K OHM +-5% 1/16W	1.000
R606	061L0603103	CHIPR 10K OHM +-5% 1/16W	1.000
R607	061L0603103	CHIPR 10K OHM +-5% 1/16W	1.000
R613	061L0603103	CHIPR 10K OHM +-5% 1/16W	1.000
R614	061L0603103	CHIPR 10K OHM +-5% 1/16W	1.000
R615	061L0603103	CHIPR 10K OHM +-5% 1/16W	1.000
R644	061L0603103	CHIPR 10K OHM +-5% 1/16W	1.000
R645	061L0603103	CHIPR 10K OHM +-5% 1/16W	1.000
R646	061L0603103	CHIPR 10K OHM +-5% 1/16W	1.000
R652	061L0603103	CHIPR 10K OHM +-5% 1/16W	1.000
R335	061L0603103	CHIPR 10K OHM +-5% 1/16W	1.000
R318	061L0603103	CHIPR 10K OHM +-5% 1/16W	1.000
R317	061L0603103	CHIPR 10K OHM +-5% 1/16W	1.000
R308	061L0603103	CHIPR 10K OHM +-5% 1/16W	1.000
R211	061L0603103	CHIPR 10K OHM +-5% 1/16W	1.000
R208	061L0603103	CHIPR 10K OHM +-5% 1/16W	1.000
R202	061L0603103	CHIPR 10K OHM +-5% 1/16W	1.000
R617	061L0603121	CHIPR 120 OHM 1/10W	1.000
R618	061L0603121	CHIPR 120 OHM 1/10W	1.000
R201	061L0603203	CHIPR 20K OHM+-5% 1/10W	1.000
R610	061L0603221	CHIPR 220 OHM+-5% 1/16W	1.000
R611	061L0603221	CHIPR 220 OHM+-5% 1/16W	1.000
R503	061L0603222	CHIPR 2.2K OHM+-5% 1/16W	1.000
R314	061L0603222	CHIPR 2.2K OHM+-5% 1/16W	1.000
R313	061L0603222	CHIPR 2.2K OHM+-5% 1/16W	1.000
R647	061L0603223	CHIPR 22K OHM +-5% 1/16W	1.000
R301	061L0603330	CHIPR 33 OHM +-5% 1/10W	1.000
R302	061L0603330	CHIPR 33 OHM +-5% 1/10W	1.000
R303	061L0603330	CHIPR 33 OHM +-5% 1/10W	1.000
R403	061L0603390 0F	CHIP 390 OHM 1/10W 1%	1.000
R304	061L0603471	CHIPR 470 OHM+-5% 1/16W	1.000
R620	061L0603471	CHIPR 470 OHM+-5% 1/16W	1.000
R621	061L0603471	CHIPR 470 OHM+-5% 1/16W	1.000
R622	061L0603471	CHIPR 470 OHM+-5% 1/16W	1.000
R623	061L0603471	CHIPR 470 OHM+-5% 1/16W	1.000
R205	061L0603472	CHIPR 4.7K OHM +-5% 1/16W	1.000
R207	061L0603472	CHIPR 4.7K OHM +-5% 1/16W	1.000
R212	061L0603472	CHIPR 4.7K OHM +-5% 1/16W	1.000

R616	061L0603472	CHIPR 4.7K OHM +-5% 1/16W	1.000
R619	061L0603472	CHIPR 4.7K OHM +-5% 1/16W	1.000
R215	061L0603513	CHIP 51K OHM	1.000
R327	061L0603750	CHIPR 75 OHM+-5% 1/16W	1.000
R326	061L0603750	CHIPR 75 OHM+-5% 1/16W	1.000
R325	061L0603750	CHIPR 75 OHM+-5% 1/16W	1.000
R651	061L0603912	CHIPR 9.1KOHM +-5% 1/10W	1.000
C220	065G0603102 32	1000PF +-10% 50V X7R	1.000
C221	065G0603102 32	1000PF +-10% 50V X7R	1.000
C307	065G0603102 32	1000PF +-10% 50V X7R	1.000
C326	065G0603102 32	1000PF +-10% 50V X7R	1.000
C606	065G0603102 32	1000PF +-10% 50V X7R	1.000
C607	065G0603102 32	1000PF +-10% 50V X7R	1.000
C608	065G0603102 32	1000PF +-10% 50V X7R	1.000
C609	065G0603102 32	1000PF +-10% 50V X7R	1.000
C610	065G0603102 32	1000PF +-10% 50V X7R	1.000
C620	065G0603102 32	1000PF +-10% 50V X7R	1.000
C621	065G0603102 32	1000PF +-10% 50V X7R	1.000
C406	065G0603104 32	CHIP 0.1UF 50V X7R	1.000
C407	065G0603104 32	CHIP 0.1UF 50V X7R	1.000
C408	065G0603104 32	CHIP 0.1UF 50V X7R	1.000
C409	065G0603104 32	CHIP 0.1UF 50V X7R	1.000
C410	065G0603104 32	CHIP 0.1UF 50V X7R	1.000
C411	065G0603104 32	CHIP 0.1UF 50V X7R	1.000
C412	065G0603104 32	CHIP 0.1UF 50V X7R	1.000
C413	065G0603104 32	CHIP 0.1UF 50V X7R	1.000
C415	065G0603104 32	CHIP 0.1UF 50V X7R	1.000
C416	065G0603104 32	CHIP 0.1UF 50V X7R	1.000
C417	065G0603104 32	CHIP 0.1UF 50V X7R	1.000
C619	065G0603104 32	CHIP 0.1UF 50V X7R	1.000
C618	065G0603104 32	CHIP 0.1UF 50V X7R	1.000
C601	065G0603104 32	CHIP 0.1UF 50V X7R	1.000
C510	065G0603104 32	CHIP 0.1UF 50V X7R	1.000
C428	065G0603104 32	CHIP 0.1UF 50V X7R	1.000
C426	065G0603104 32	CHIP 0.1UF 50V X7R	1.000
C425	065G0603104 32	CHIP 0.1UF 50V X7R	1.000
C423	065G0603104 32	CHIP 0.1UF 50V X7R	1.000
C421	065G0603104 32	CHIP 0.1UF 50V X7R	1.000

C420	065G0603104 32	CHIP 0.1UF 50V X7R	1.000
C418	065G0603104 32	CHIP 0.1UF 50V X7R	1.000
C201	065G0603104 32	CHIP 0.1UF 50V X7R	1.000
C203	065G0603104 32	CHIP 0.1UF 50V X7R	1.000
C205	065G0603104 32	CHIP 0.1UF 50V X7R	1.000
C207	065G0603104 32	CHIP 0.1UF 50V X7R	1.000
C210	065G0603104 32	CHIP 0.1UF 50V X7R	1.000
C212	065G0603104 32	CHIP 0.1UF 50V X7R	1.000
C214	065G0603104 32	CHIP 0.1UF 50V X7R	1.000
C216	065G0603104 32	CHIP 0.1UF 50V X7R	1.000
C313	065G0603104 32	CHIP 0.1UF 50V X7R	1.000
C401	065G0603104 32	CHIP 0.1UF 50V X7R	1.000
C404	065G0603104 32	CHIP 0.1UF 50V X7R	1.000
C217	065G0603105 17	1UF 16V Y5V	1.000
C403	065G0603220 31	CER1 0603 NP0 50V 22P PM5 R	1.000
C602	065G0603220 31	CER1 0603 NP0 50V 22P PM5 R	1.000
C312	065G0603221 31	CER1 0603 NP0 50V 220P PM5 R	1.000
C605	065G0603224 17	CAP:CER 0.22UF -20%-80% 10V SM	1.000
C604	065G0603270 31	27PF 50V NPO	1.000
C311	065G0603330 31	CER1 0603 NP0 50V 33P PM5 R	1.000
C402	065G0603390 31	CHIP 39PF 50V NPO	1.000
C304	065G0603473 32	CHIP 0.047UF 50V X7R	1.000
C305	065G0603473 32	CHIP 0.047UF 50V X7R	1.000
C306	065G0603473 32	CHIP 0.047UF 50V X7R	1.000
C308	065G0603473 32	CHIP 0.047UF 50V X7R	1.000
C309	065G0603473 32	CHIP 0.047UF 50V X7R	1.000
C310	065G0603473 32	CHIP 0.047UF 50V X7R	1.000
FB402	071G 56K121 M	CHIP BEAD	1.000
FB201	071G 56Z601	CHIP BEAD 600 OHM 0805	1.000
FB401	071G 56Z601	CHIP BEAD 600 OHM 0805	1.000
FB403	071G 56Z601	CHIP BEAD 600 OHM 0805	1.000
FB404	071G 56Z601	CHIP BEAD 600 OHM 0805	1.000
FB405	071G 56Z601	CHIP BEAD 600 OHM 0805	1.000
FB406	071G 56Z601	CHIP BEAD 600 OHM 0805	1.000
FB304	071G 59B431	BK1608 HW 431	1.000
D323	093G 39147	TZMC5V6	1.000
D322	093G 39147	TZMC5V6	1.000
D321	093G 39147	TZMC5V6	1.000

D320	093G 39147	TZMC5V6	1.000
D319	093G 39147	TZMC5V6	1.000
D318	093G 39147	TZMC5V6	1.000
D304	093G 64 42 P	BAV70 SOT-23	1.000
D601	093G 6432V	LL4148-GS08	1.000
D324	093G 6433P	BAV99	1.000
D303	093G 6433P	BAV99	1.000
D302	093G 6433P	BAV99	1.000
D301	093G 6433P	BAV99	1.000
D201	093G1004 3	SS14	1.000
D202	093G1020 1 S	GS1D	1.000
	715G1423 3512	PCB	1.000
L1	071G 59B601 EA	CHIP BEAD 600 OHM	1.000
ZD02	093G 39147	TZMC5V6	1.000
ZD01	093G 39147	TZMC5V6	1.000
	AIK980KUSNP	MAIN BAORD	1.000
R903	061G152M10458F	100K OHM 5% 2W	1.000
	096G 29 6	SHRINK TUBE UL/CSA	20.000
Q901	057G 600 35	STP8NK80ZFP	1.000
	090G 415505	HEATSHINK	1.000
	0M1G1730 8128	SCREW M3x8	1.000
	087G 501 12 CJ	AC SOCKET	1.000
	095G 900 43	SIGNAL CABLE	1.000
	096G 29 6	SHRINK TUBE UL/CSA	1.000
	090G6081 1	HEATSHINK FOR U301	1.000
D911	093G 60242	SRF20150C T0-220	1.000
D910	093G 60242	SRF20150C T0-220	1.000
	0M1G1730 8128	SCREW M3x8	2.000
IC901	056G 379 33 1	IC SG6841SZ3 SOP-8 SYSTEM GENERAL	1.000
IC101	056G 379 37	FP5001DR	1.000
IC201	056G 608 7	OZT1060GN SOIC-20	1.000
Q902	057G 417 4	PMBS3904/PHILIPS-SMT(04)	1.000
Q206	057G 417 4	PMBS3904/PHILIPS-SMT(04)	1.000
Q102	057G 417 4	PMBS3904/PHILIPS-SMT(04)	1.000
Q903	057G 417 6	PMBS3906/PHILIPS-SMT(06)	1.000
Q103	057G 417 6	PMBS3906/PHILIPS-SMT(06)	1.000
Q210	057G 60040A	AM4512C-T1-PF SO-8	1.000
Q209	057G 60040A	AM4512C-T1-PF SO-8	1.000

Q208	057G 60040A	AM4512C-T1-PF SO-8	1.000
Q204	057G 60040A	AM4512C-T1-PF SO-8	1.000
Q213	057G 759 2	RK7002	1.000
Q212	057G 759 2	RK7002	1.000
Q211	057G 759 2	RK7002	1.000
Q215	057G 759 2	RK7002	1.000
Q214	057G 759 2	RK7002	1.000
Q205	057G 760 4B	PDTA144WK SOT346	1.000
Q207	057G 760 5B	PDTC144WK SOT346	1.000
Q101	057G 763 3	AO4411 SO-8	1.000
R248	061L0603000	RST SM 0603 JUMP MAX 0R05 R	1.000
R242	061L0805000	CHIPR 0OHM +-5% 1/10W	1.000
R240	061L0805000	CHIPR 0OHM +-5% 1/10W	1.000
R235	061L0805000	CHIPR 0OHM +-5% 1/10W	1.000
R230	061L0805000	CHIPR 0OHM +-5% 1/10W	1.000
R214	061L0805000	CHIPR 0OHM +-5% 1/10W	1.000
R206	061L0805000	CHIPR 0OHM +-5% 1/10W	1.000
C103	061L0805000	CHIPR 0OHM +-5% 1/10W	1.000
R923	061L0805000	CHIPR 0OHM +-5% 1/10W	1.000
R925	061L0805000	CHIPR 0OHM +-5% 1/10W	1.000
R909	061L0805100	CHIPR 10 OHM+-5% 1/10W	1.000
R216	061L0805100 4F	CHIPR 1M OHM +-1% 1/8W	1.000
R114	061L0805102	CHIPR 1K OHM +-5% 1/10W	1.000
R205	061L0805102	CHIPR 1K OHM +-5% 1/10W	1.000
R218	061L0805102	CHIPR 1K OHM +-5% 1/10W	1.000
R239	061L0805102	CHIPR 1K OHM +-5% 1/10W	1.000
R922	061L0805102	CHIPR 1K OHM +-5% 1/10W	1.000
R924	061L0805102	CHIPR 1K OHM +-5% 1/10W	1.000
R928	061L0805102	CHIPR 1K OHM +-5% 1/10W	1.000
R207	061L0805103	CHIPR 10K OHM +-5% 1/10W	1.000
R204	061L0805103	CHIPR 10K OHM +-5% 1/10W	1.000
R203	061L0805103	CHIPR 10K OHM +-5% 1/10W	1.000
R243	061L0805105	CHIP 1M OHM 5% 1/8W	1.000
R241	061L0805105	CHIP 1M OHM 5% 1/8W	1.000
R238	061L0805105	CHIP 1M OHM 5% 1/8W	1.000
R231	061L0805105	CHIP 1M OHM 5% 1/8W	1.000
R223	061L0805105	CHIP 1M OHM 5% 1/8W	1.000
R228	061L0805153	CHIPR 15K OHM+-5% 1/8W	1.000

R212	061L0805153	CHIPR 15K OHM+-5% 1/8W	1.000
R111	061L0805153	CHIPR 15K OHM+-5% 1/8W	1.000
R245	061L0805155	CHIP 1.5M OHM 5% 1/8W	1.000
R912	061L0805203	CHIPR 20KOHM +-5% 1/8W	1.000
R225	061L0805205	CHIP 2M OHM 5% 1/8W	1.000
R115	061L0805220	CHIP 22 OHM 5% 0805 1/8W	1.000
R209	061L0805220	CHIP 22 OHM 5% 0805 1/8W	1.000
R220	061L0805220	CHIP 22 OHM 5% 0805 1/8W	1.000
R201	061L0805222	CHIP 2.2KOHM 5% 0805 1/8W	1.000
R911	061L0805240 2F	CHIP 24KOHM 1% 1/8W	1.000
R927	061L0805243 1F	CHIP 2.43K OHM 1/8W 1%	1.000
R112	061L0805272	CHIP 2.7K OHM 1/8W	1.000
R109	061L0805302	CHIP 3KOHM+-5% 1/8W	1.000
C232	061L0805303	CHIP 30K OHM 1/8W	1.000
R116	061L0805332	CHIP 3.3K OHM +-5% 1/8W	1.000
R106	061L0805333	CHIP 33KOHM 1% 1/8W	1.000
R229	061L0805362	CHIP 306KOHM 1/8W	1.000
R213	061L0805362	CHIP 306KOHM 1/8W	1.000
R110	061L0805365 1F	SMD 3.65KOHM/0805/+1%	1.000
R247	061L0805431	CHIP 430OHM 5% 0805 1/8W	1.000
R246	061L0805431	CHIP 430OHM 5% 0805 1/8W	1.000
R234	061L0805431	CHIP 430OHM 5% 0805 1/8W	1.000
R227	061L0805431	CHIP 430OHM 5% 0805 1/8W	1.000
R215	061L0805431	CHIP 430OHM 5% 0805 1/8W	1.000
R210	061L0805431	CHIP 430OHM 5% 0805 1/8W	1.000
R113	061L0805470	CHIP 47 OHM 1/10W	1.000
R916	061L0805472	CHIPR 4.7K OHM +-5% 1/10W	1.000
R918	061L0805472	CHIPR 4.7K OHM +-5% 1/10W	1.000
R108	061L0805473	CHIPR 47K OHM +-5% 1/8W	1.000
R222	061L0805513	CHIP 51KOHM 1/8W	1.000
R217	061L0805623	CHIPR 62K OHM +-5% 1/10W	1.000
R236	061L0805823	chip 82kohm 1/8w	1.000
R926	061L0805931 1F	CHIP 9.31K OHM 1/8W 1%	1.000
D205	061L1206000	CHIPR 0 OHM +-5% 1/8W	1.000
R202	061L1206000	CHIPR 0 OHM +-5% 1/8W	1.000
R919	061L1206000	CHIPR 0 OHM +-5% 1/8W	1.000
F201	061L1206000 4	0 OHM 4A 1/4W	1.000
R929	061L1206101	CHIP 100 OHM 5% 1/8W	1.000

R907	061L1206105	CHIP 1MOHM 5% 1/4W	1.000
R906	061L1206105	CHIP 1MOHM 5% 1/4W	1.000
R905	061L1206105	CHIP 1MOHM 5% 1/4W	1.000
R904	061L1206105	CHIP 1MOHM 5% 1/4W	1.000
R913	061L1206203	20K OHM 5% 1/4W	1.000
R910	061L1206221	CHIP 220 OHM 1/4W	1.000
R921	061L1206301	CHIP 300OHM 1/4W	1.000
R915	061L1206303	CHIP 30K OHM 1% 1/4W	1.000
R902	061L1206394	CHIPR 390KOHM+-5% 1/4W	1.000
R901	061L1206394	CHIPR 390KOHM+-5% 1/4W	1.000
R900	061L1206394	CHIPR 390KOHM+-5% 1/4W	1.000
R244	061L1206471	CHIPR 470 OHM+-5% 1/8W	1.000
R908	061L1206519	CHIPR 5.1OHM +-5% 1/4W	1.000
C931	065G0603102 31	CHIP 1000PF 50V NPO	1.000
C910	065G0805102 31	1000PF 50V NPO	1.000
C104	065G0805104 22	0.1UF +-10% 25V X7R 080	1.000
C212	065G0805104 32	CHIP 0.1U 50V X7R	1.000
C217	065G0805104 32	CHIP 0.1U 50V X7R	1.000
C226	065G0805104 32	CHIP 0.1U 50V X7R	1.000
C229	065G0805104 32	CHIP 0.1U 50V X7R	1.000
C235	065G0805104 32	CHIP 0.1U 50V X7R	1.000
C918	065G0805104 32	CHIP 0.1U 50V X7R	1.000
C920	065G0805104 32	CHIP 0.1U 50V X7R	1.000
C908	065G0805104 32	CHIP 0.1U 50V X7R	1.000
C911	065G0805104 32	CHIP 0.1U 50V X7R	1.000
C912	065G0805104 32	CHIP 0.1U 50V X7R	1.000
C917	065G0805104 32	CHIP 0.1U 50V X7R	1.000
C240	065G0805104 32	CHIP 0.1U 50V X7R	1.000
C243	065G0805104 32	CHIP 0.1U 50V X7R	1.000
C245	065G0805104 32	CHIP 0.1U 50V X7R	1.000
C246	065G0805104 32	CHIP 0.1U 50V X7R	1.000
C247	065G0805104 32	CHIP 0.1U 50V X7R	1.000
C211	065G0805104 32	CHIP 0.1U 50V X7R	1.000
C210	065G0805104 32	CHIP 0.1U 50V X7R	1.000
C202	065G0805104 32	CHIP 0.1U 50V X7R	1.000
C115	065G0805104 32	CHIP 0.1U 50V X7R	1.000
C114	065G0805104 32	CHIP 0.1U 50V X7R	1.000
C213	065G0805105 37	CHIP 1UF 50V Y5V	1.000

C219	065G0805105 37	CHIP 1UF 50V Y5V	1.000
C222	065G0805105 37	CHIP 1UF 50V Y5V	1.000
C215	065G0805152 22	CHIP 0.005UF 25V X7R 0805	1.000
C241	065G0805152 22	CHIP 0.005UF 25V X7R 0805	1.000
C220	065G0805221 21	220PF 25V 5%	1.000
C244	065G0805225 12	CHIP 2.2UF 15V X7R 0805	1.000
C242	065G0805332 32	3200PF/25V/X7R	1.000
C216	065G0805332 32	3200PF/25V/X7R	1.000
C924	065G0805334 22	0.33UF+-10% 25V X7R 0805	1.000
C909	065G0805471 21	CHIP 470PF 25V NPO	1.000
C214	065G0805473 22	SMD 47nf +-10%25V XTR	1.000
C230	065G0805473 22	SMD 47nf +-10%25V XTR	1.000
C221	065G0805474 22	CHIP 0.47UF 25V X7R 0805	1.000
C228	065G0805682 32	CHIP 6.8UF 50V X7R 0805	1.000
C268	065G1206105 32	CHIP 1UF 50V X7R 1206	1.000
C267	065G1206105 32	CHIP 1UF 50V X7R 1206	1.000
C266	065G1206105 32	CHIP 1UF 50V X7R 1206	1.000
C265	065G1206105 32	CHIP 1UF 50V X7R 1206	1.000
C234	065G1206225 17	1206 2.2UF -20%~+80% 16V Y5V	1.000
C233	065G1206225 17	1206 2.2UF -20%~+80% 16V Y5V	1.000
C231	065G1206225 17	1206 2.2UF -20%~+80% 16V Y5V	1.000
C207	065G1206225 17	1206 2.2UF -20%~+80% 16V Y5V	1.000
C206	065G1206225 17	1206 2.2UF -20%~+80% 16V Y5V	1.000
C203	065G1206225 17	1206 2.2UF -20%~+80% 16V Y5V	1.000
D903	093G 6432V	LL4148-GS08	1.000
D213	093G 6432V	LL4148-GS08	1.000
D208	093G 6432V	LL4148-GS08	1.000
D210	093G 6433P	BAV99	1.000
D209	093G 6433P	BAV99	1.000
D207	093G 6433P	BAV99	1.000
D206	093G 6433P	BAV99	1.000
D204	093G 6433P	BAV99	1.000
D203	093G 6433P	BAV99	1.000
D202	093G 6433P	BAV99	1.000
D201	093G 6433P	BAV99	1.000
ZD902	093G 39S 17 T	RLZ12B LLDS	1.000
ZD901	093G 39S 20 T	RLZ22B LLDS	1.000
ZD203	093G 39S 24 T	RLZ 5.6B LLDS	1.000

ZD202	093G 39S 24 T	RLZ 5.6B LLDS	1.000
ZD201	093G 39S 24 T	RLZ 5.6B LLDS	1.000
D101	093G3004 2	SR34 PAN JIT	1.000
	PW1942HSU4AIP	19" LCD POWER BOARD FOR AI	1.000
	715G1820 2	KEY BOARD	1.000
L904	006G 31502	1.5MM RIVET	4.000
L902	006G 31502	1.5MM RIVET	4.000
F901	006G 31502	1.5MM RIVET	2.000
C905	006G 31502	1.5MM RIVET	2.000
NR901	006G 31502	1.5MM RIVET	2.000
PT201	006G 31502	1.5MM RIVET	2.000
PT202	006G 31502	1.5MM RIVET	2.000
Q901	006G 31502	1.5MM RIVET	1.000
T901	006G 31502	1.5MM RIVET	4.000
IC903	056G 158 4 T	H431BA	1.000
R208	061G212Y305 KT	MGFR 3M OHM +-5% 1/2W	1.000
R224	061G212Y305 KT	MGFR 3M OHM +-5% 1/2W	1.000
C906	065G 2K152 1T6921	1.5NF/2KV Y5P +-10%	1.000
C925	065G517K102 5T	1000PF 10% Y5P 500V	1.000
JP204	071G 55 19 T	FERRITE BEAD D9X3. 5X0.8	1.000
FB901	071G 55 29	FERRITE BEAD	1.000
D901	093G 6026W52T	FR107	1.000
D902	093G 6038P52T	PS102R	1.000
D904	093G 64 1152T	1N4148	1.000
	715G1349 3	POWER BOARD	1.000