

Service
Service
Service

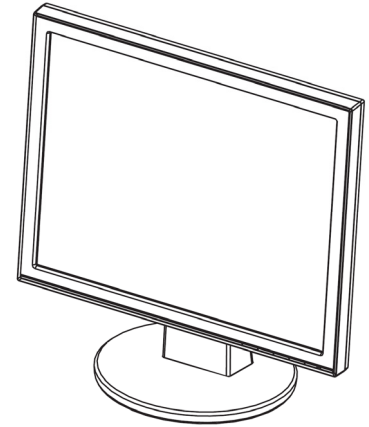

Service Manual

Horizontal Frequency
30-82 KHz

TABLE OF CONTENTS

Description	Page	Description	Page
Table Of Contents.....	1	6.Schematic.....	21
Revision List.....	2	6.1.Main Board.....	21
Important Safety Notice.....	3	6.2.Power Board.....	31
1.Monitor Specification.....	4	6.3.Audio Board.....	33
2.LCD Monitor Description.....	5	7.PCB Layout.....	34
3.Operation Instruction.....	6	7.1.Main Board.....	34
3.1.General Instructions.....	6	7.2.Power Board.....	37
3.2.Control Button.....	6	7.3.Audio Board.....	39
3.3.OSD Menu.....	7	7.4.Key Board.....	40
4.Input/Output Specification.....	11	8.Maintainability.....	41
4.1.Input Signal Connector.....	11	8.1.Equipments and Tools Requirement.....	41
4.2.Power Supply Requirements.....	12	8.2.Trouble Shooting.....	42
4.3.Factory Preset Display Modes.....	13	9.White-Balance, Luminance adjustment.....	48
4.4.Panel Specification.....	14	10.Monitor Exploded View.....	50
5.Block Diagram.....	17	11.BOM List.....	51
5.1.Software Flow Chart.....	17	12.Different Parts List.....	77
5.2.Electrical Block Diagram.....	19		

SAFETY NOTICE

ANY PERSON ATTEMPTING TO SERVICE THIS CHASSIS MUST FAMILIARIZE HIMSELF WITH THE CHASSIS AND BE AWARE OF THE NECESSARY SAFETY PRECAUTIONS TO BE USED WHEN SERVICING ELECTRONIC EQUIPMENT CONTAINING HIGH VOLTAGES.

CAUTION: USE A SEPARATE ISOLATION TRANSFORMER FOR THIS UNIT WHEN SERVICING

Revision List

Version	Release Date	Revision History	TPV Model Name
A00	Jun.21, 2007	Initial release	T97HMKDBHGUED
			T97HMKDDHGUSD
			T97HMWDKHGUSA
A01	Jul.20,2007	Add new BOM in Item 12	T97HMKDBHGUSD
			T97HMWDTHGUSA
A02	Oct.23,2007	Add new BOM in Item 12	T97HMWDTHGUSAZ
			T97HMKDDHGUSDZ
			T97HMKDTHGUSD

Important Safety Notice

Proper service and repair is important to the safe, reliable operation of all AOC Company Equipment. The service procedures recommended by AOC and described in this service manual are effective methods of performing service operations. Some of these service operations require the use of tools specially designed for the purpose. The special tools should be used when and as recommended.

It is important to note that this manual contains various CAUTIONS and NOTICES which should be carefully read in order to minimize the risk of personal injury to service personnel. The possibility exists that improper service methods may damage the equipment. It is also important to understand that these CAUTIONS and NOTICES ARE NOT EXHAUSTIVE. AOC could not possibly know, evaluate and advise the service trade of all conceivable ways in which service might be done or of the possible hazardous consequences of each way. Consequently, AOC has not undertaken any such broad evaluation. Accordingly, a servicer who uses a service procedure or tool which is not recommended by AOC must first satisfy himself thoroughly that neither his safety nor the safe operation of the equipment will be jeopardized by the service method selected.

Hereafter throughout this manual, AOC Company will be referred to as AOC.

WARNING

Use of substitute replacement parts, which do not have the same, specified safety characteristics may create shock, fire, or other hazards.

Under no circumstances should the original design be modified or altered without written permission from AOC. AOC assumes no liability, express or implied, arising out of any unauthorized modification of design. Servicer assumes all liability.

FOR PRODUCTS CONTAINING LASER:

DANGER-Invisible laser radiation when open AVOID DIRECT EXPOSURE TO BEAM.

CAUTION-Use of controls or adjustments or performance of procedures other than those specified herein may result in hazardous radiation exposure.

CAUTION -The use of optical instruments with this product will increase eye hazard.

TO ENSURE THE CONTINUED RELIABILITY OF THIS PRODUCT, USE ONLY ORIGINAL MANUFACTURER'S REPLACEMENT PARTS, WHICH ARE LISTED WITH THEIR PART NUMBERS IN THE PARTS LIST SECTION OF THIS SERVICE MANUAL.

Take care during handling the LCD module with backlight unit

- Must mount the module using mounting holes arranged in four corners.
- Do not press on the panel, edge of the frame strongly or electric shock as this will result in damage to the screen.
- Do not scratch or press on the panel with any sharp objects, such as pencil or pen as this may result in damage to the panel.
- Protect the module from the ESD as it may damage the electronic circuit (C-MOS).
- Make certain that treatment person's body is grounded through wristband.
- Do not leave the module in high temperature and in areas of high humidity for a long time.
- Avoid contact with water as it may a short circuit within the module.
- If the surface of panel becomes dirty, please wipe it off with a soft material. (Cleaning with a dirty or rough cloth may damage the panel.)

1. Monitor Specifications

LCD Panel	Driving system	TFT Color LCD
	Size	19"
	Type	HSD190MEN3-A
	Pixel pitch	0.294mm(H)x 0.294mm(V)
	Response time (type)	5ms for HSD panel
	Viewable angle	170° (H) 160° (V) (CR>10)
	Video	R,G,B Analog Interface Digital Interface (only for VB191T)
Input	Sync. Type	H/V TTL
	H-Frequency	30kHz – 82kHz
	V-Frequency	56-76 Hz
Power Consumption	ON Mode	<42W
	OFF Mode	<2W
Display Color	16.7M (6-bits+Hi FRC)	
Dot Clock	150MHz	
Contrast Ratio	1000:1	
White Luminance	300cd/m ²	
Max. Resolution	1280 x 1024	
Plug & Play	VESA DDC2B™	
Power Source	100~240VAC,47~63Hz	
Input Connector	D-Sub 15pin	
	DVI 24pin (only for VB191T)	
Input Video Signal	Analog:0.7Vp-p(standard),75 OHM, Positive	
	Digital signal (only for VB191T)	
Safety Certifications	UL/CUL , FCC, CE, Gost-R, BSMI,CCC,VCCI,C-Tick, CB, RoHS required	
Maximum Screen Size	Horizontal : 376.32mm	
	Vertical: 301.056mm	
Environmental Considerations	Operating Temp: 0°C to 35°C	
	Storage Temp: -20°C to 60°C	
	Operating Humidity: 45% to 85%	

2. LCD Monitor Description

The LCD monitor will contain a main board, an audio board, a power board and a key board which house the flat panel control logic, brightness control logic and DDC.

The power board will provide AC to DC Inverter voltage to drive the backlight of panel and the main board chips each voltage.

Monitor Block Diagram

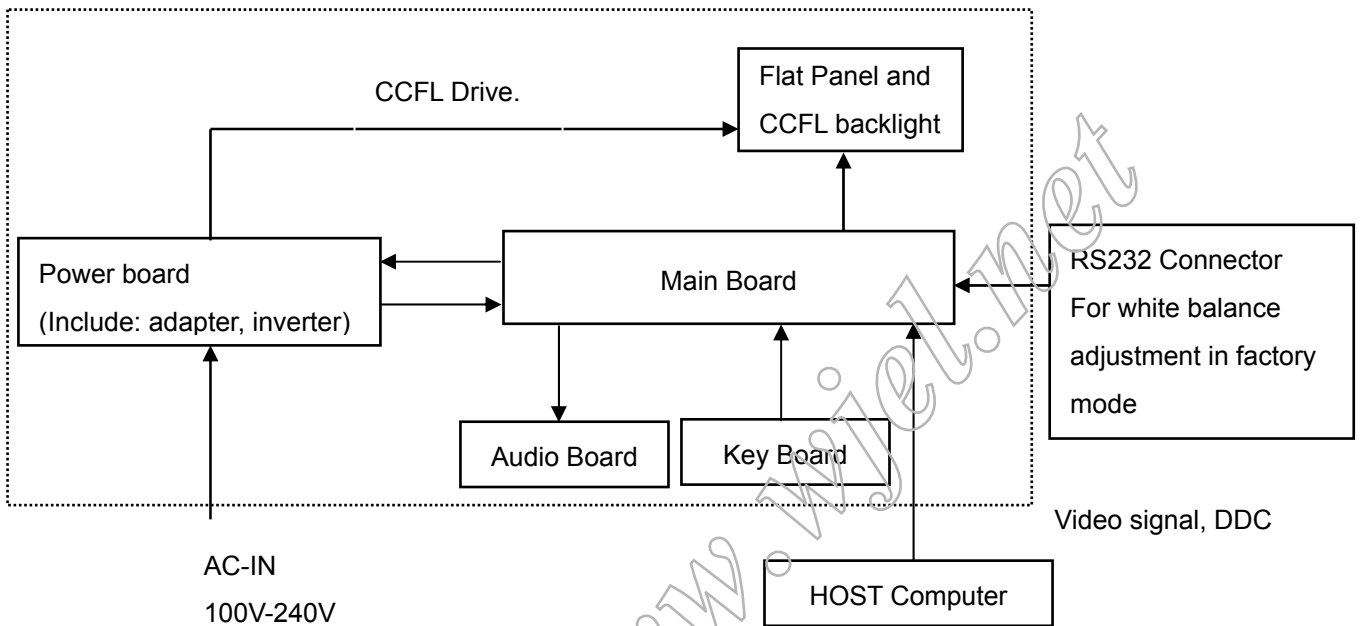

3. Operating Instructions

3.1 General Instructions

Press the power button to turn the monitor on or off. The other control buttons are located at the front of the panel of the monitor.

By changing these settings, the picture can be adjusted to your personal preferences.

- The power cord should be connected.
- Connect the video cable from the monitor to the video card.
- Press the power button to turn on the monitor, the power indicator will light up.

3.2 Control Buttons

3.2.1 Key Control

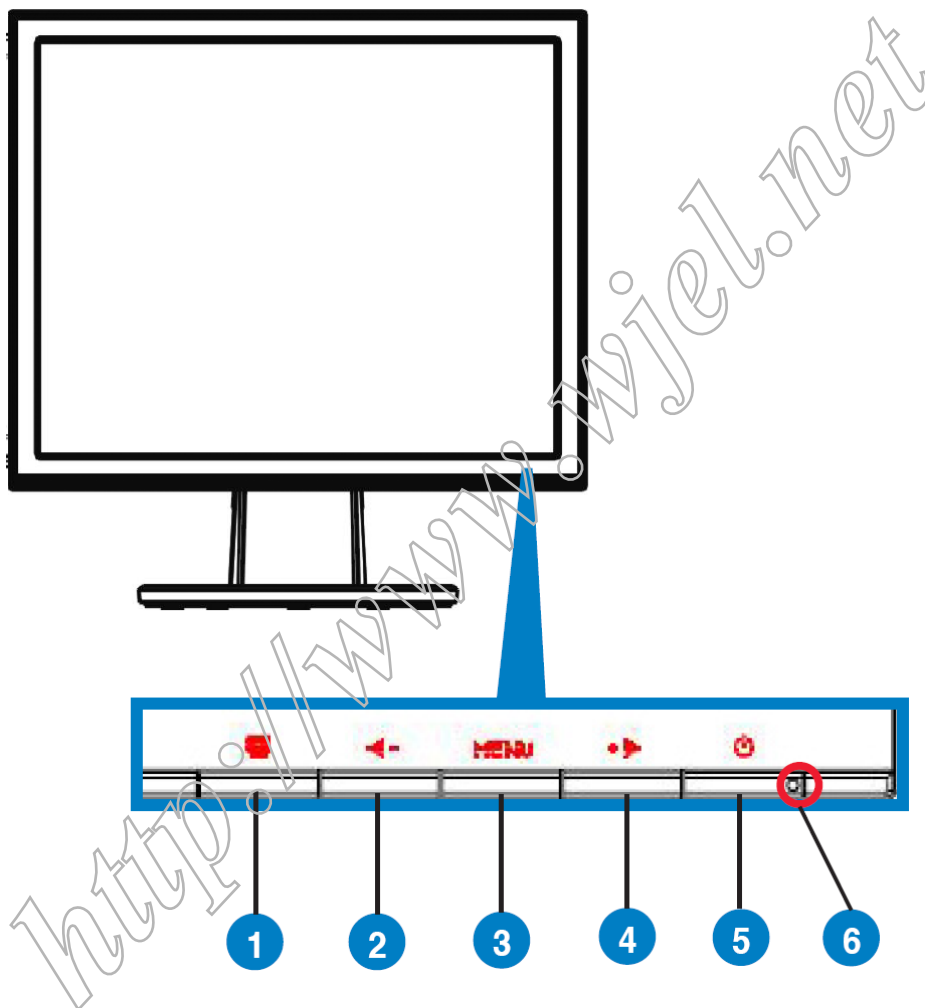

3.2.2 Key Function

1. **S** button:
 - Automatically adjust the image to its optimized position, clock, and phase by long pressing this button for 2-4 seconds (for VGA mode only).
 - Use this hotkey to switch from five video preset modes (Game Mode, Night View Mode, Scenery Mode, Standard Mode, Theater Mode) with SPLENDID™ Video Enhancement Technology.
 - Exit the OSD menu or go back to the previous menu as the OSD menu is active.
2. **◀** - Button:
 - Press this button to decrease the value of the function selected or move to the previous function.
 - This is also a hotkey for Volume adjustment. (For Some Models)
3. MENU Button:
 - Press this button to enter/select the icon (function) highlighted while the OSD menu is activated.
4. **+ ▶** Button:
 - Press this button to increase the value of the function selected or move to the next function.
 - This is also a hotkey for Brightness adjustment.

3.3 OSD Menu

3.3.1 How to Reconfigure



1. Press the MENU button to activate the OSD menu.

2. Press ◀- and +▶ to navigate through the functions. Highlight and activate the desired function by pressing the MENU button. If the function selected has a sub-menu, press + and - again to navigate through the sub-menu functions. Highlight and activate the desired sub-menu function by pressing the MENU button.
3. Press ◀- and +▶ to change the settings of the selected function.
4. To exit the OSD menu, press the **S** button. Repeat step 2 and step 3 to adjust any other function.

3.3.2 OSD Function Introduction

1. Splendid

This function contains five sub-functions you can select for your preference. Each mode has the Reset selection, allowing you to maintain your setting or return to the preset mode.



- **Scenery Mode:** best choice for scenery photo display with SPLENDID™ Video Enhancement.
- **Standard Mode:** best choice for document editing with SPLENDID™ Video Enhancement.
- **Theater Mode:** best choice for movie with SPLENDID™ Video Enhancement.
- **Game Mode:** best choice for game playing with SPLENDID™ Video Enhancement.
- **Night View Mode:** best choice for dark-scene game or movie with SPLENDID™ Video Enhancement.



- In the Standard Mode, the **Saturation** and **Sharpness** functions are not user-configurable.
- In the other modes, the **sRGB** function is not user-configurable.

2. Image

You can adjust brightness, contrast, sharpness, saturation, position (VGA only), and focus (VGA only) from this main function.

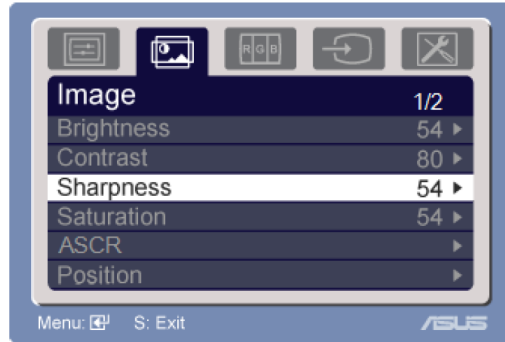

- Brightness: the adjusting range is from 0 to 100. +▶ is a hotkey to activate this function.
- Contrast: the adjusting range is from 0 to 100.
- Sharpness: the adjusting range is from 0 to 100.
- Saturation: the adjusting range is from 0 to 100.
- Switch ON or OFF THE ASCR function.(This function is for some models only)
- Position: adjusts the horizontal position (H-Position) and the vertical position (V-Position) of the image. The adjusting range is from 0 to 100.
- Focus: reduces Horizontal-line noise and Vertical-line noise of the image by adjusting (Phase) and (Clock) separately. The adjusting range is from 0 to 100.



- Phase adjusts the phase of the pixel clock signal. With a wrong phase adjustment, the screen shows horizontal disturbances.
- Clock (pixel frequency) controls the number of pixels scanned by one horizontal sweep. If the frequency is not correct, the screen shows vertical stripes and the image is not proportional.

3. Color

Select the image color you like from this function.

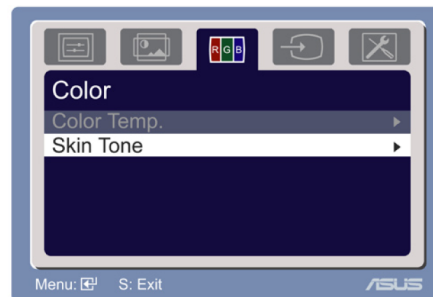

- Color Temp.: contains five color modes including Cool, Normal, Warm, sRGB, and User mode.
- Skin Tone: contains three color modes including Reddish, Natural, and Yellowish.



In the User mode, colors of R (Red), G (Green), and B (Blue) are user-configurable; the adjusting range is from 0-100.

4. Input Select

In this function, you can select either VGA or DVI input source.
(Only for some models)

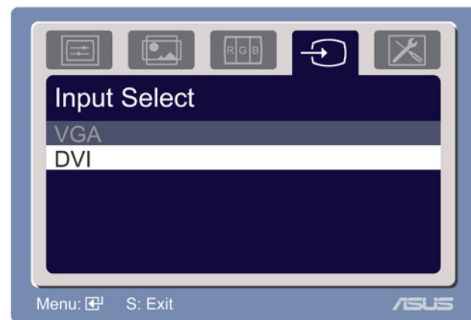

5. System Setup

Allow you to adjust the system.



- Volume: the adjusting range is from 0 to 100. is a hotkey to activate this function.
- OSD Setup: adjusts the horizontal position (H-Position) and the vertical position (V-Position) of the OSD. The adjusting range is from 0 to 100. In the OSD Timeout selection, you can adjust the OSD timeout from 10 to 120. For DDC/CI setting, you can switch ON or OFF.
- Language: there are ten languages for your selection, including English, German, Italian, French, Dutch, Spanish, Russian, Traditional Chinese, Simplified Chinese, Japanese, and Korean.
- Information: shows the monitor information.
- Reset: "Yes" allows you to revert to the preset mode.

4. Input/Output Specification

4.1 Input Signal Connector

Analog connectors

Pin No.	Description	Pin No.	Description
1.	Red Video	9.	+5V
2.	Green Video	10.	Logic Ground
3.	Blue Video	11.	Monitor Ground
4.	Monitor Ground	12.	DDC-Serial Data
5.	DDC-Return	13.	H-Sync
6.	Red Ground	14.	V-Sync
7.	Green Ground	15.	DDC-Serial Clock
8.	Blue Ground		

VGA connector layout

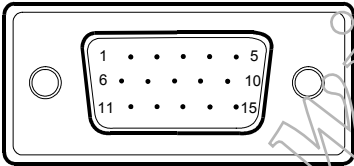

DVI connectors

Pin No.	Description	Pin No.	Description	Pin No.	Description
1.	RX2-	9.	R X1-	17.	RX0-
2.	RX2+	10.	RX1+	18.	RX0+
3.	RX2 Shield	11.	RX1 Shield	19.	RX0 Shield
4.	NC	12.	NC	20.	NC
5.	NC	13.	NC	21.	NC
6.	DDC Clock	14.	+5V Power	22.	RX Clock Shield
7.	DDC Data	15.	Ground	23.	RX Clock+
8.	NC	16.	Hot Plug Detection	24.	RX Clock-

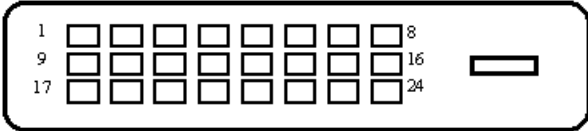

4.2 Power Supply Requirements

A/C Line voltage range	100 V ~ 240 V
A/C Line frequency range	50 ± 3Hz, 60 ± 3Hz
Input Voltage transients	90-264 voltage AC for 10 sec @40°C
Current	1.5A max at 100V; 0.8A max at 240 V
Peak surge current	< 60A peak at 240 VAC and cold starting < 30A peak at 120VAC and cold starting
Leakage current	< 3.5mA
Power line surge	No advance effects (no loss of information or defect) with a maximum of 1 half-wave missing per second

<http://www.wjel.net>

4.3 Factory Preset Display Modes

Standard	Resolution Frequency	Horizontal Frequency (KHz)	Pixel (MHz)
VGA	640x480@60Hz	31.469	25.175
	640x480@72Hz	37.861	31.5
	640x480@75Hz	37.5	31.5
SVGA	800x600@56Hz	35.156	36
	800x600@60Hz	37.879	40
	800x600@72Hz	48.077	50
	800x600@75Hz	46.875	49.5
XGA	1024x768@60Hz	48.363	65
	1024x768@70Hz	56.476	75
	1024x768@72Hz	57.7	78.4
	1024x768@75Hz	60.023	78.75
Mac	1024x768@75Hz	60.2	80
	1152x870@75Hz	68.7	100
	1152x864@75Hz	67.5	108
	1280x960@60Hz	60	108
SXGA	1280x1024@60Hz	63.981	108
	1280x1024@70Hz	74.4	124.9
	1280x1024@72Hz	77.9	134.6
	1280x1024@75Hz	79.976	135

IBM MODES

Standard	Resolution Frequency	Horizontal Frequency (KHz)	Pixel (MHz)
DOS*	640x350@70Hz	31.469	25.175
DOS	720x400@70Hz	31.469	28.322

MAC MODES

Standard	Resolution Frequency	Horizontal Frequency (KHz)	Pixel (MHz)
VGA	640x480@67Hz	35	30.24
SVGA	832x624@75Hz	49.725	57.2832

* Modes not listed in the above tables may not be supported. For optimal resolution, we recommend that you choose a mode listed in the above tables

4.4 Panel Specification

4.4.1 Features

- _ 19" SXGA TFT LCD Panel
- _ 4 CCFLs Backlight System
- _ Supported SXGA (V:1024 lines, H:1280 pixels) Resolution
- _ Supported to 75Hz Refresh Rate
- _ LCD Timing Controller
- _ RoHS Compliance
- _ VESA Compatible

4.4.2 Display Characteristics

Item	Specification		Unit
Outline dimension	396 * 324 * 16.5(Typ)		mm
Display area	376.32 (H) x301.056 (V) (19.0" diagonal)		mm
Number of Pixel	1280(H) x 1024(V)		Pixels
Pixel pitch	0.294(H) x 0.294(V)		mm
Pixel arrangement	RGB Vertical Stripe		
Display color	16.7M (6-bits+Hi FRC)		
Color temperature	6500K		
Display mode	Normally white		
Surface treatment	Antiglare, Hard-Coating (3H)		
Weight	1950		g
Back-light	4-CCFLs, Top & bottom edge side		
Input signal	2-ch LVDS		
Power consumption	System	3.5(Typ.)	W
	B/L	19.8(Typ.)	

4.4.3 Optical Characteristics

Item	Symbol	Condition	Min.	Typ.	Max.	Unit	
Contrast	CR	$\theta = 0^\circ$ $\phi = 0^\circ$ Normal viewing angle	700	1000	--		
Response time	Rising		TR +TF	--	5.0	10	msec
	Falling			--			
White luminance (center of screen)	Y_L			250	300	--	cd/m ²
Color chromaticity (CIE1931)	Red		Rx	-0.03	0.641	+0.03	
			Ry		0.337		
	Green		Gx		0.304		
			Gy		0.620		
	Blue		Bx		0.141		
			By		0.073		
	White	Wx	0.313				
		Wy	0.329				
Viewing angle	Hor.	θ_L	75	85	--		
		θ_R	75	85	--		
	Ver.	θ_H	75	80	--		
		θ_L	75	80	--		
Viewing angle	Hor.	θ_L	75	85	--		
		θ_R	75	85	--		
	Ver.	θ_H	75	85	--		
		θ_L	75	85	--		
Brightness uniformity	B_{UNI}	$\theta = 0^\circ$ $\phi = 0^\circ$	75	--	--	%	

4.4.4 Electrical Characteristics

(1) TFT-LCD

Item	Symbol	Min.	Typ.	Max.	Unit	
Voltage of power supply	V_{DD}	4.5	5.0	5.5	V	
Current of power supply	White	I_{DD0}	405	480	555	mA
	V-Color	I_{DD1}	500	600	700	mA
	Mosaic	I_{DD2}	810	1010	1210	mA
Vsync frequency	f_V	56	60	76	Hz	
Hsync frequency	f_H	64	64	80	KHz	
Frequency	f_{DCLK}	50	54	67.5	MHz	
Input rush current	I_{RUSH}	--	--	3.0	A	

(2) Backlight

Item	Symbol	Min.	Typ.	Max.	Unit
Lamp current	IL	3.0	7.5	8.0	mA(rms)
Lamp voltage	VL	594	660	726	V(rms)
Frequency	fL	40	50	80	KHz
Operating Lifetime	Hr	40,000	--	--	Hour
Startup voltage	Vs	1400	--	--	V(rms)
		1650			

5. Block Diagram

5.1 Software Flow Chat

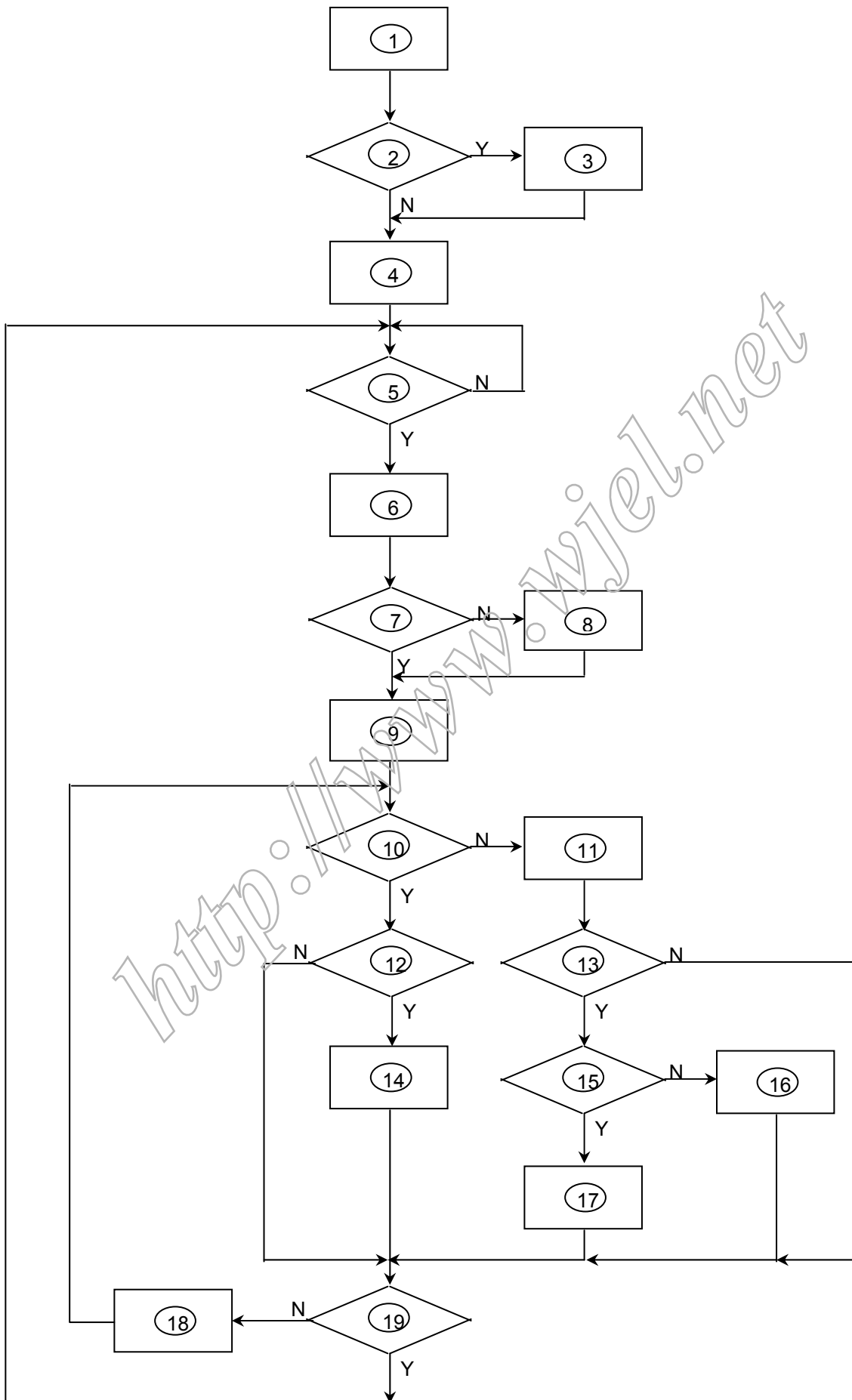

- 1) MCU initialize.
- 2) Is the EPROM blank?
- 3) Program the EPROM by default values.
- 4) Get the PWM value of brightness from EPROM.
- 5) Is the power key pressed?
- 6) Clear all global flags.
- 7) Are the AUTO and SELECT keys pressed?
- 8) Enter factory mode.
- 9) Save the power key status into EPROM.
Turn on the LED and set it to green color.
Scalar initializes.
- 10) In standby mode?
- 11) Update the lifetime of back light.
- 12) Check the analog port, are there any signals coming?
- 13) Does the scalar send out an interrupt request?
- 14) Wake up the scalar.
- 15) Are there any signals coming from analog port?
- 16) Display "No connection Check Signal Cable" message. And go into standby mode after the message disappear.
- 17) Program the scalar to be able to show the coming mode.
- 18) Process the OSD display.
- 19) Read the keyboard. Is the power key pressed?

5.2 Electrical Block Diagram

5.2.1 Main Board

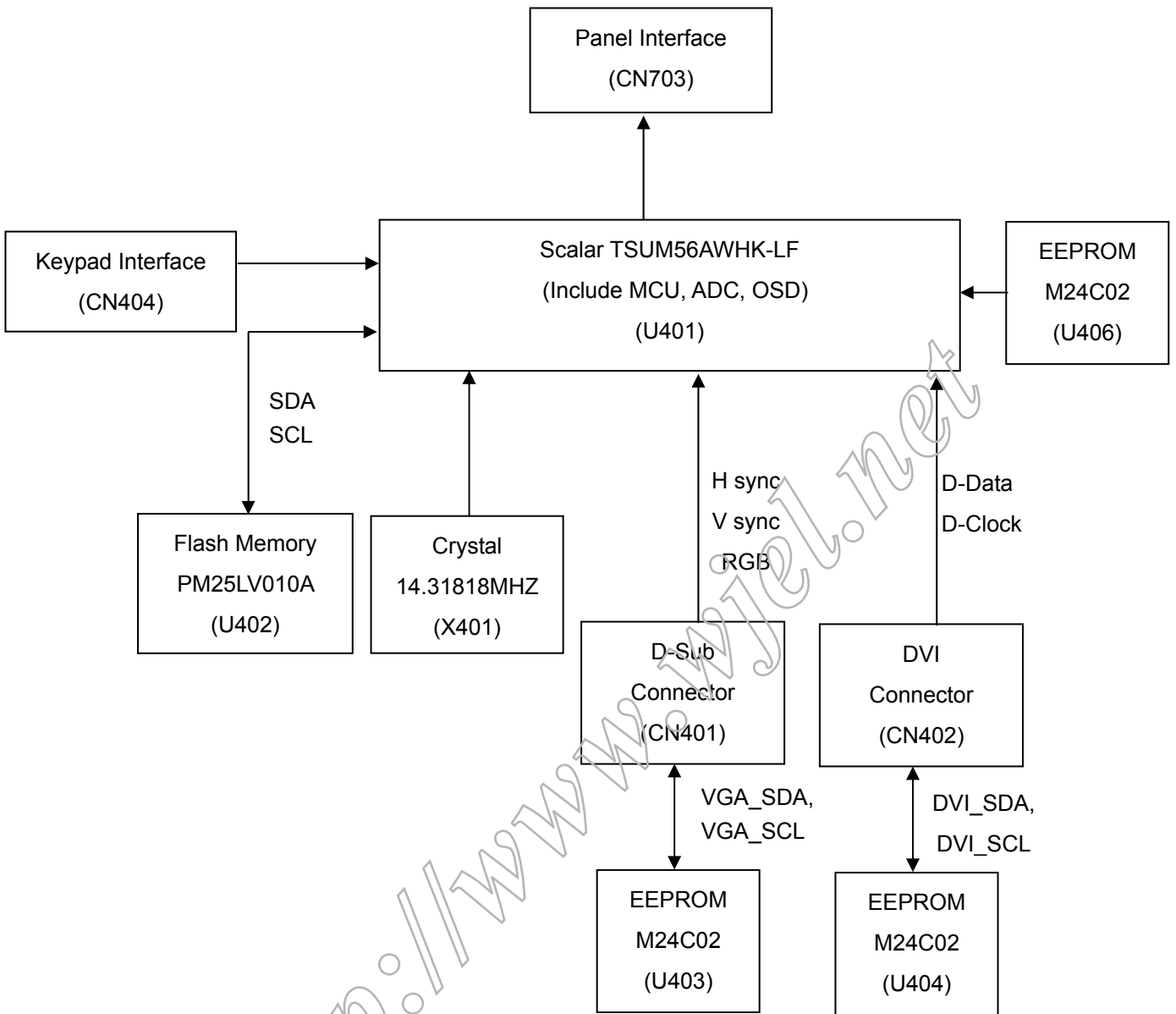

5.2.2 Inverter/Power Board

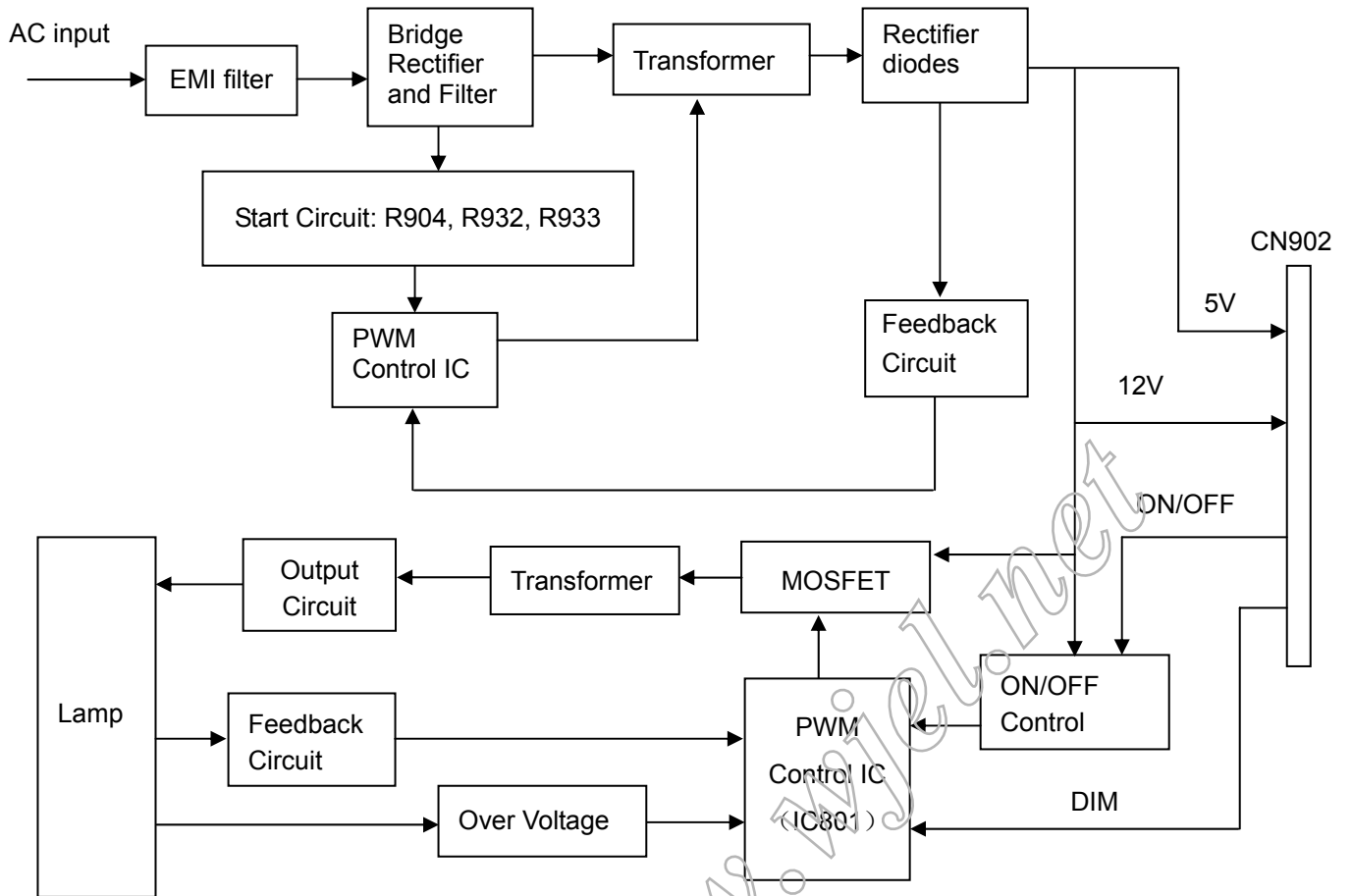

6. Schematic

6.1 Main Board

715G2571-1-2

For VB191T

TSUM56AHK

SCHEMATIC

XGA/SXGA/WSXGA

LVDS OUTPUT

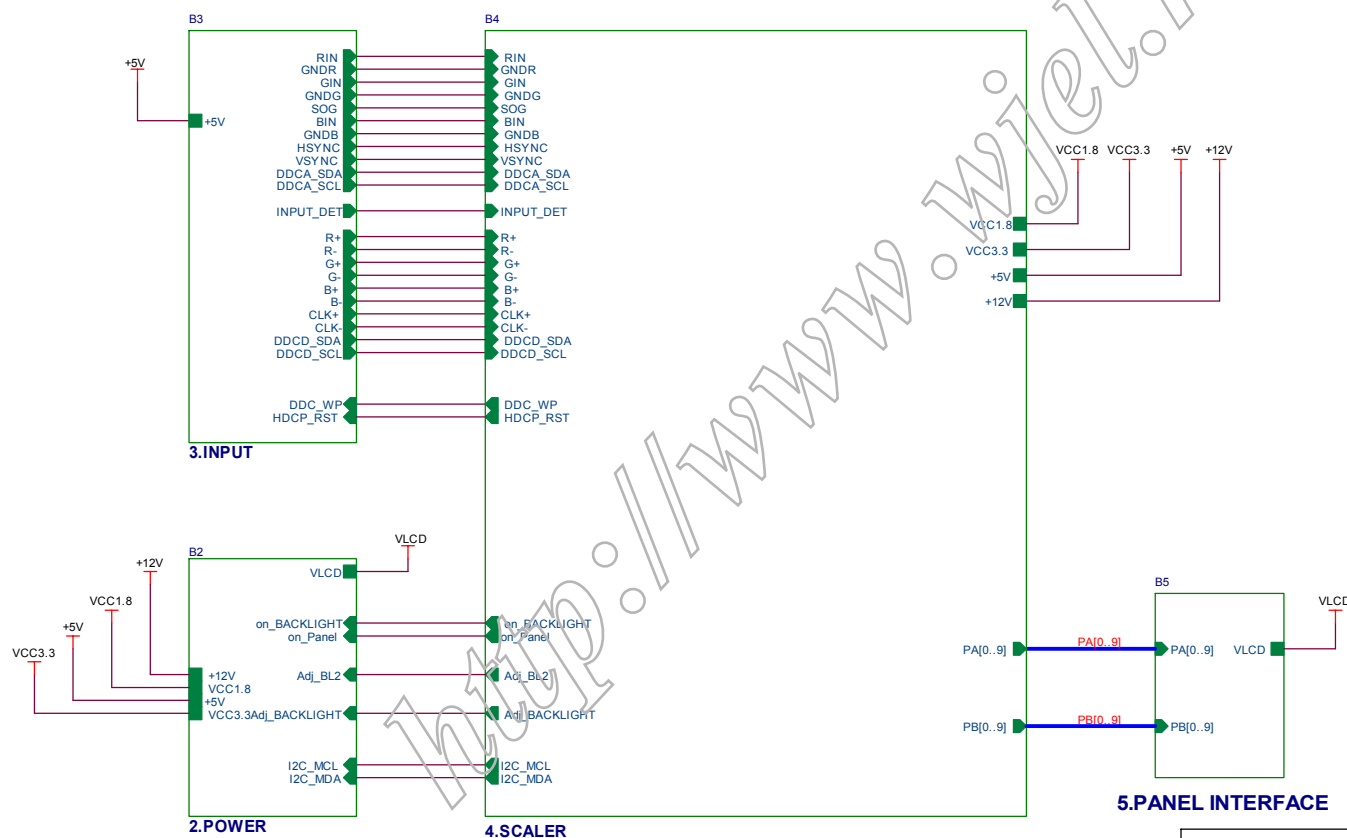

Title			1.2 TOP		
Size	Document Number				Rev
B	715G2571-1-2				A
Date:	Saturday, April 14, 2007	Sheet	1.2	of	6

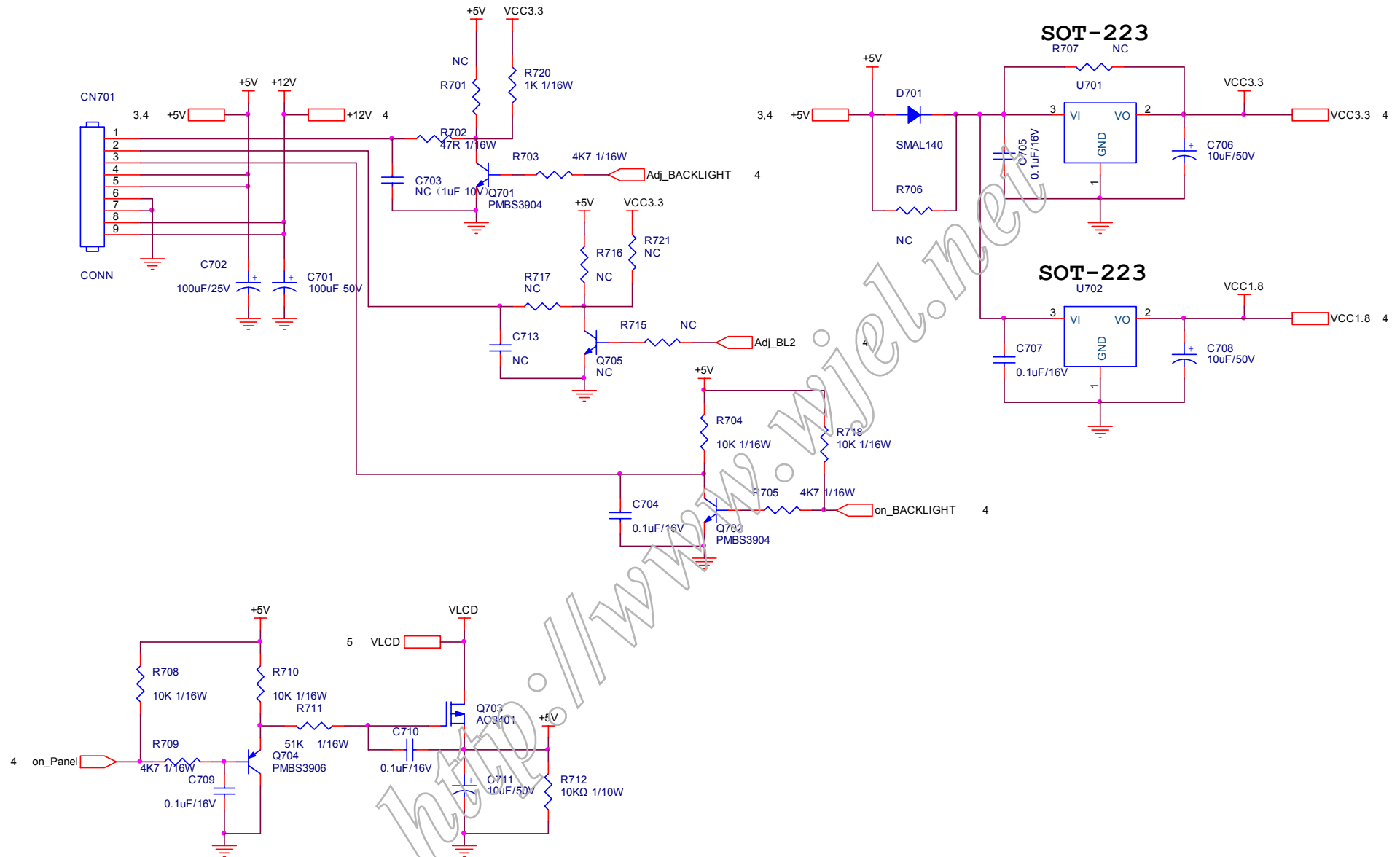

Title		
2.Power		
Size B	Document Number 715G2571-1-2	Rev A
Date:	Saturday, April 14, 2007	Sheet 2 of 6

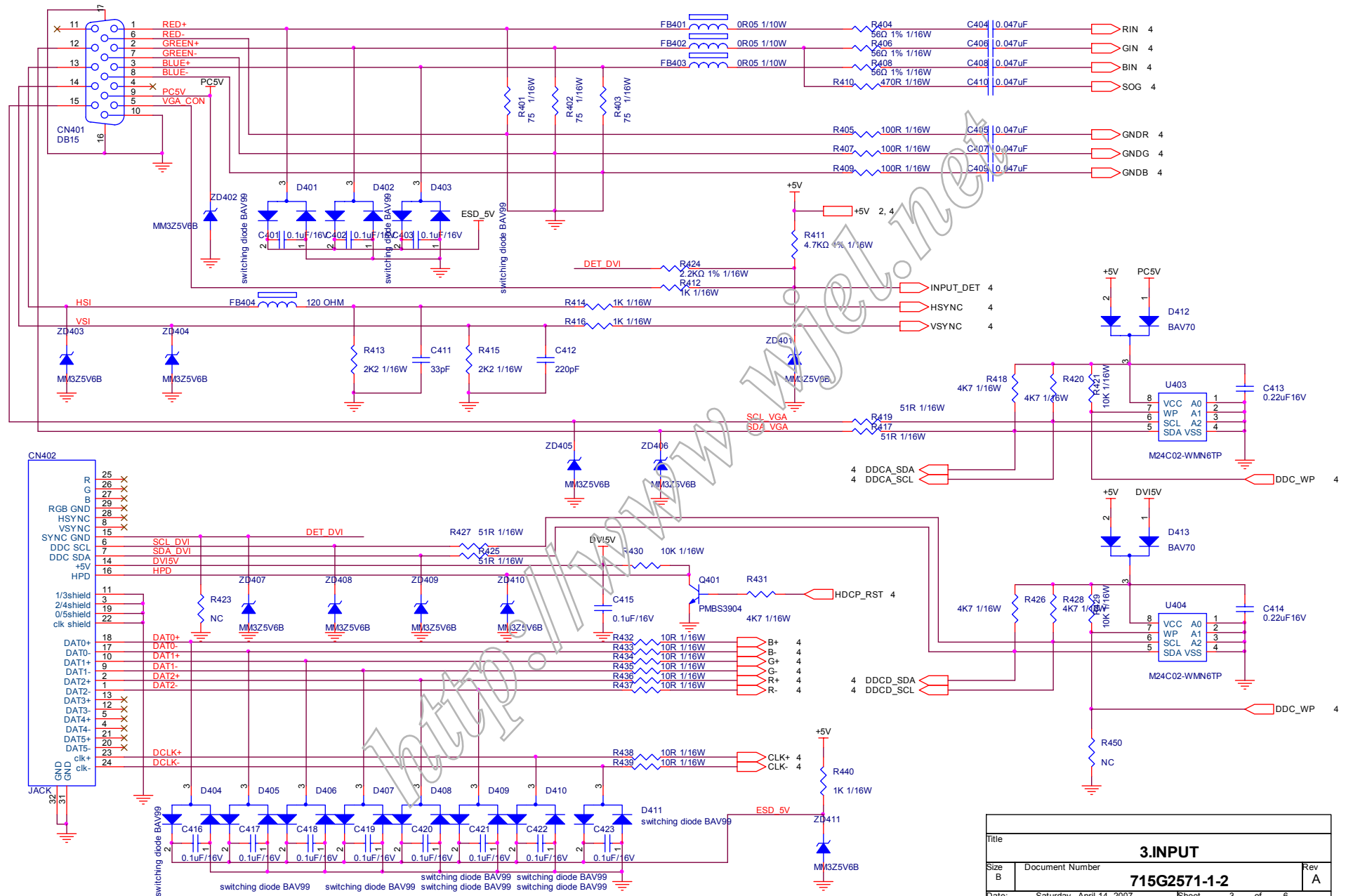

Title			3.INPUT		
Size	Document Number				Rev
B	715G2571-1-2				A
Date:	Saturday, April 14, 2007	Sheet	3	of	6

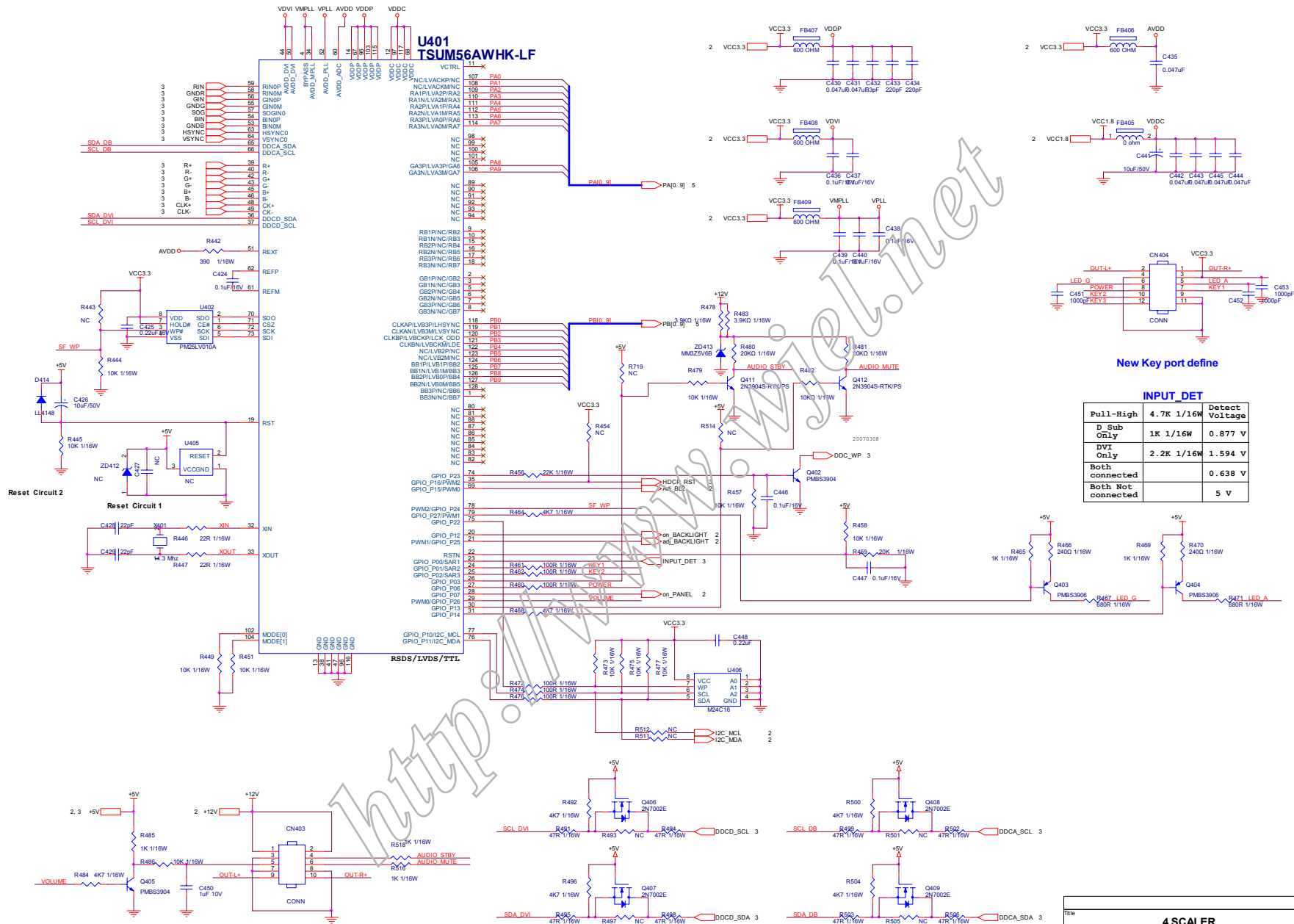

4.SCALER		
File	Document Number	Rev
C	715G2571-1-2	A
Date	Saturday, April 14, 2007	Item 4 of 8

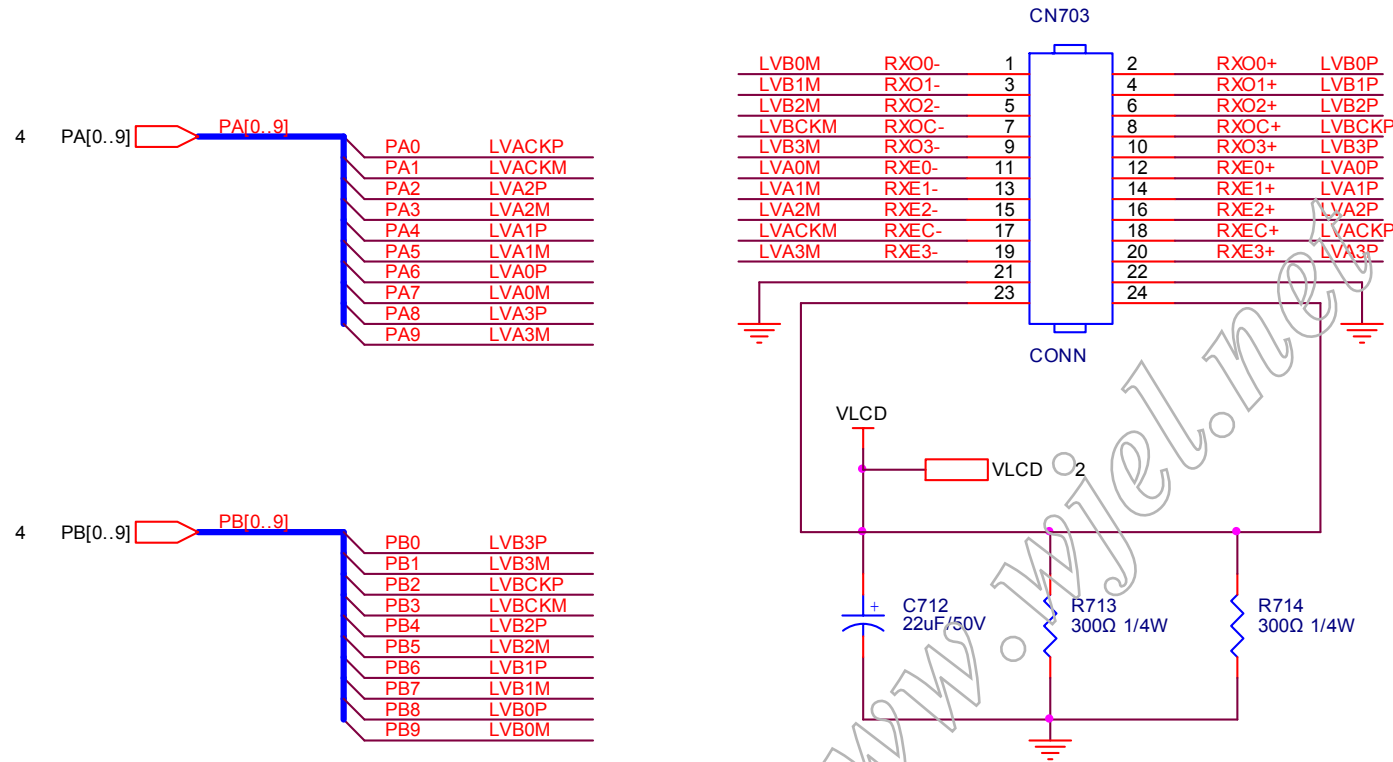

Title		
5.PANEL INTERFACE		
Size A	Document Number 715G2571-1-2	Rev A
Date:	Saturday, April 14, 2007	Sheet 5 of 6

TSUM56AHK SCHEMATIC

XGA/SXGA/WSXGA

LVDS OUTPUT

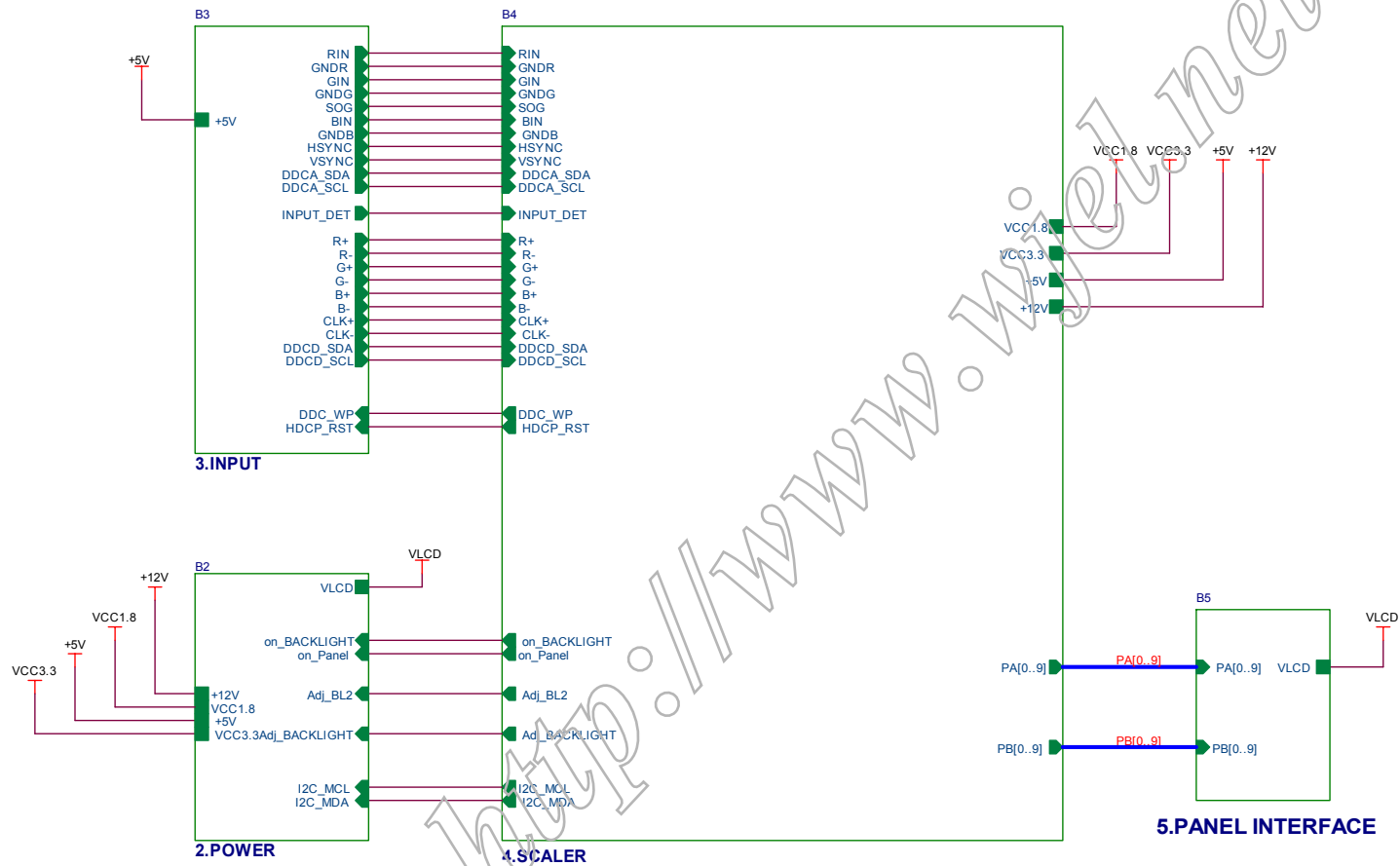

Title			
1.2 TOP			
Size B	Document Number	715G2571 1 2	Rev A
Date:	Saturday, April 14, 2007	Sheet	1.2 of 6

The type of R713 and R714 are 1206

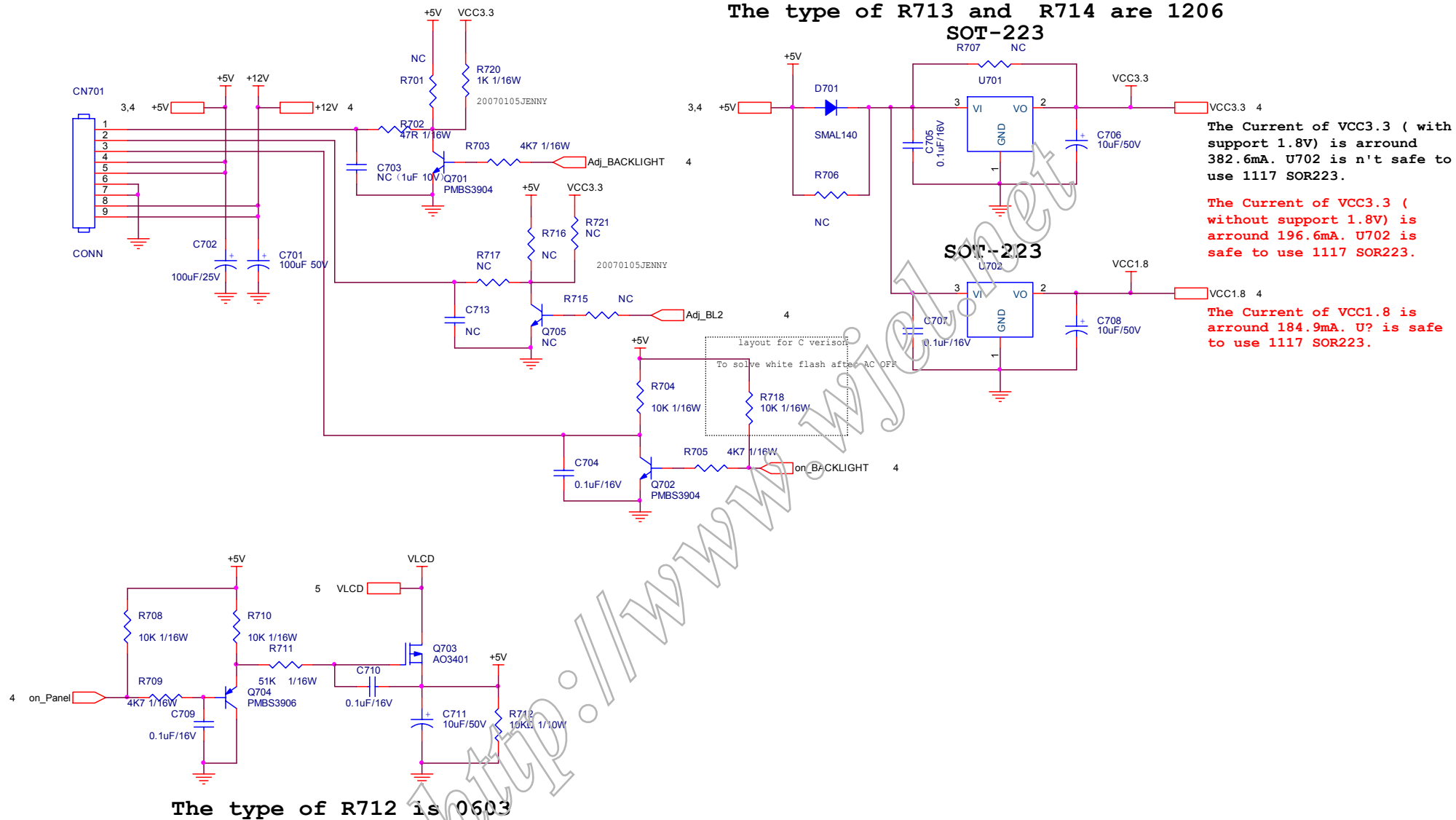

Title		
2.Power		
Size B	Document Number	Rev
	715G2571 1 2	A
Date:	Saturday, April 14, 2007	Sheet 2 of 6

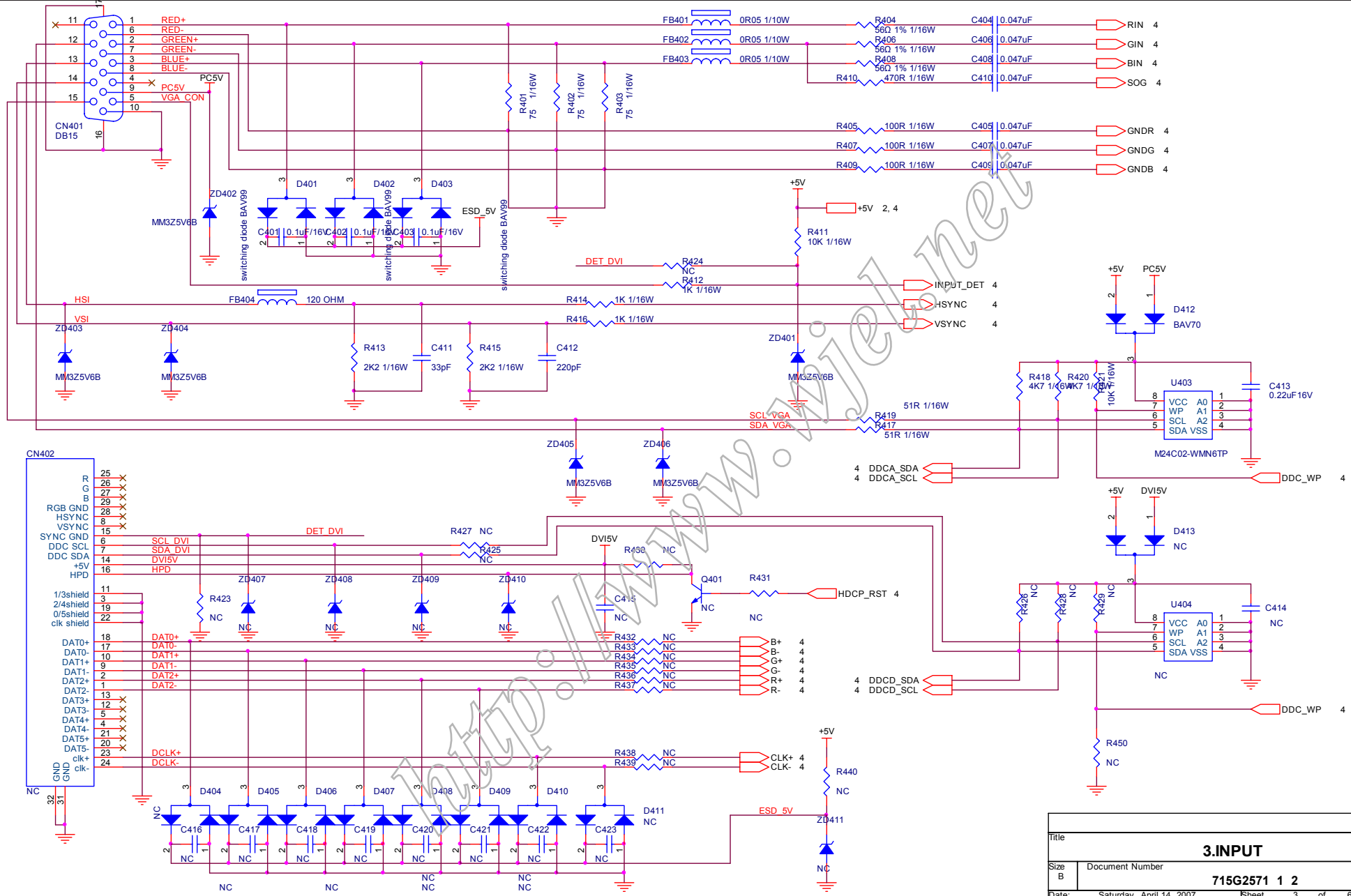

Title		
3.INPUT		
Size B	Document Number	Rev A
715G2571 1 2		
Date:	Saturday, April 14, 2007	Sheet 3 of 6

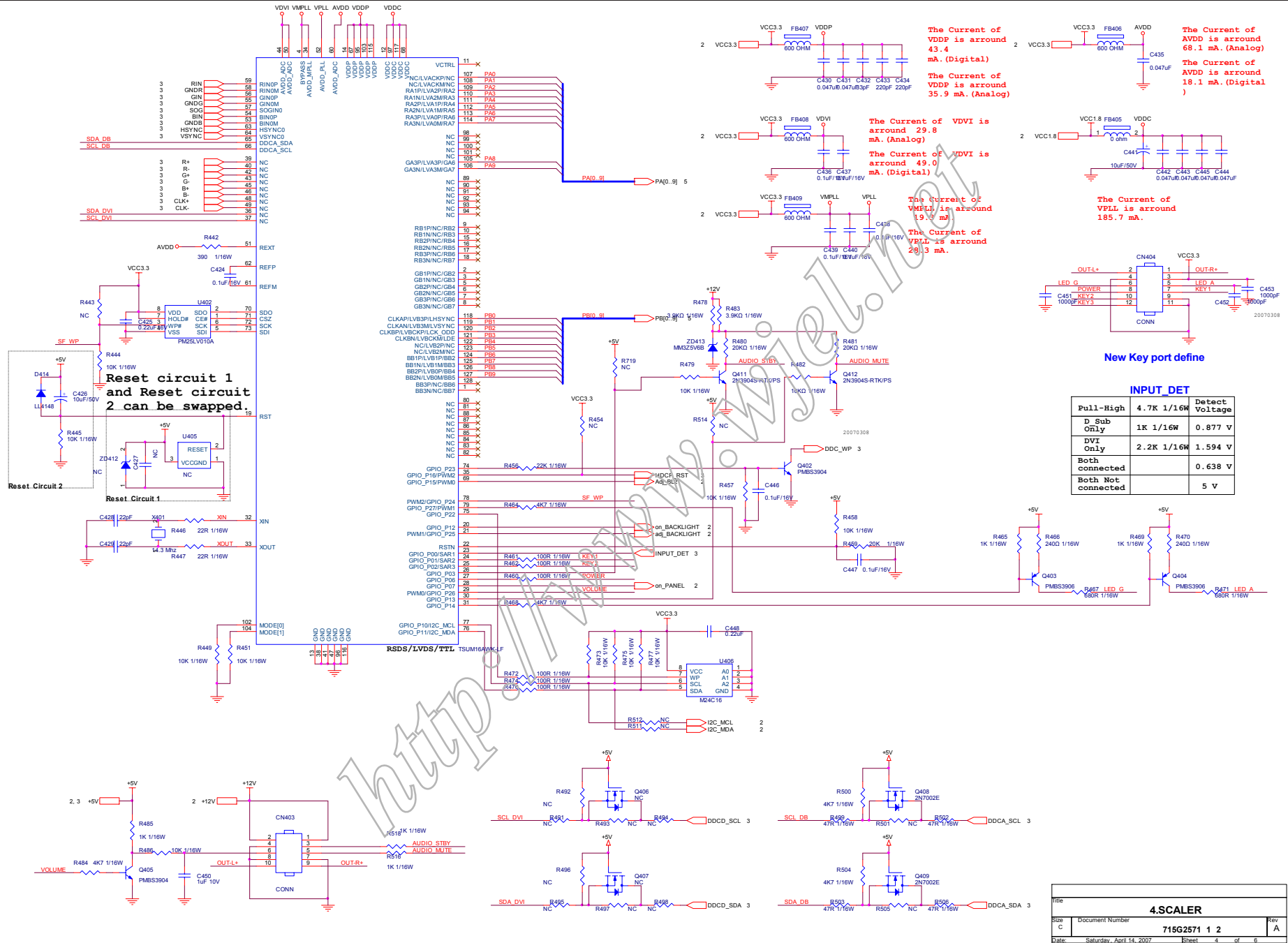

4.SCALER			
Size	Document Number		rev
C	715G2571	1 2	A
Date:	Saturday, April 14, 2007	Sheet	4 of 8

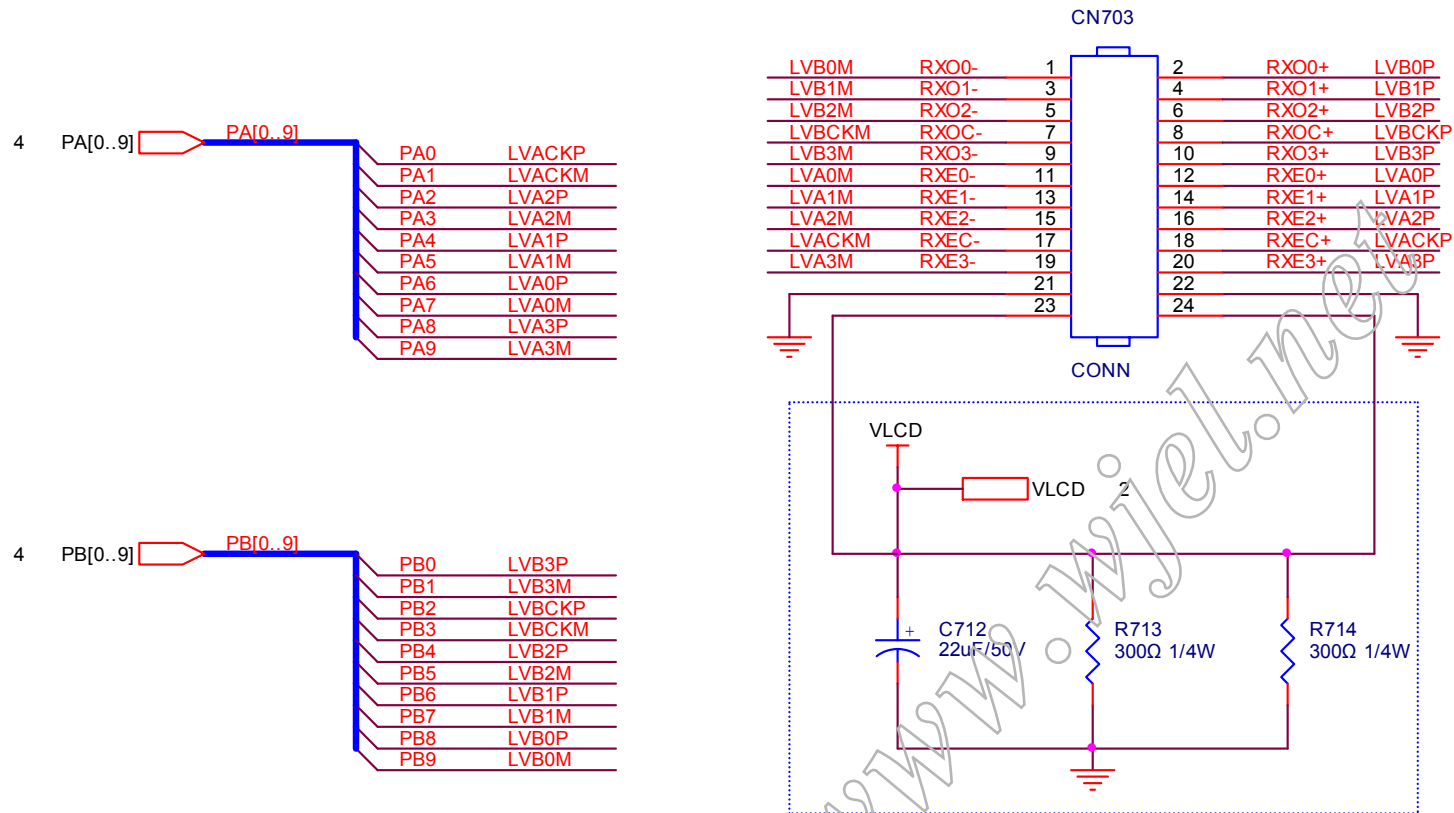

The type of R713 & R714 are 1206

Title		
5.PANEL INTERFACE		
Size A	Document Number	Rev A
	715G2571 1 2	
Date:	Saturday, April 14, 2007	Sheet 5 of 6

6.2 Power Board

715G2538-1

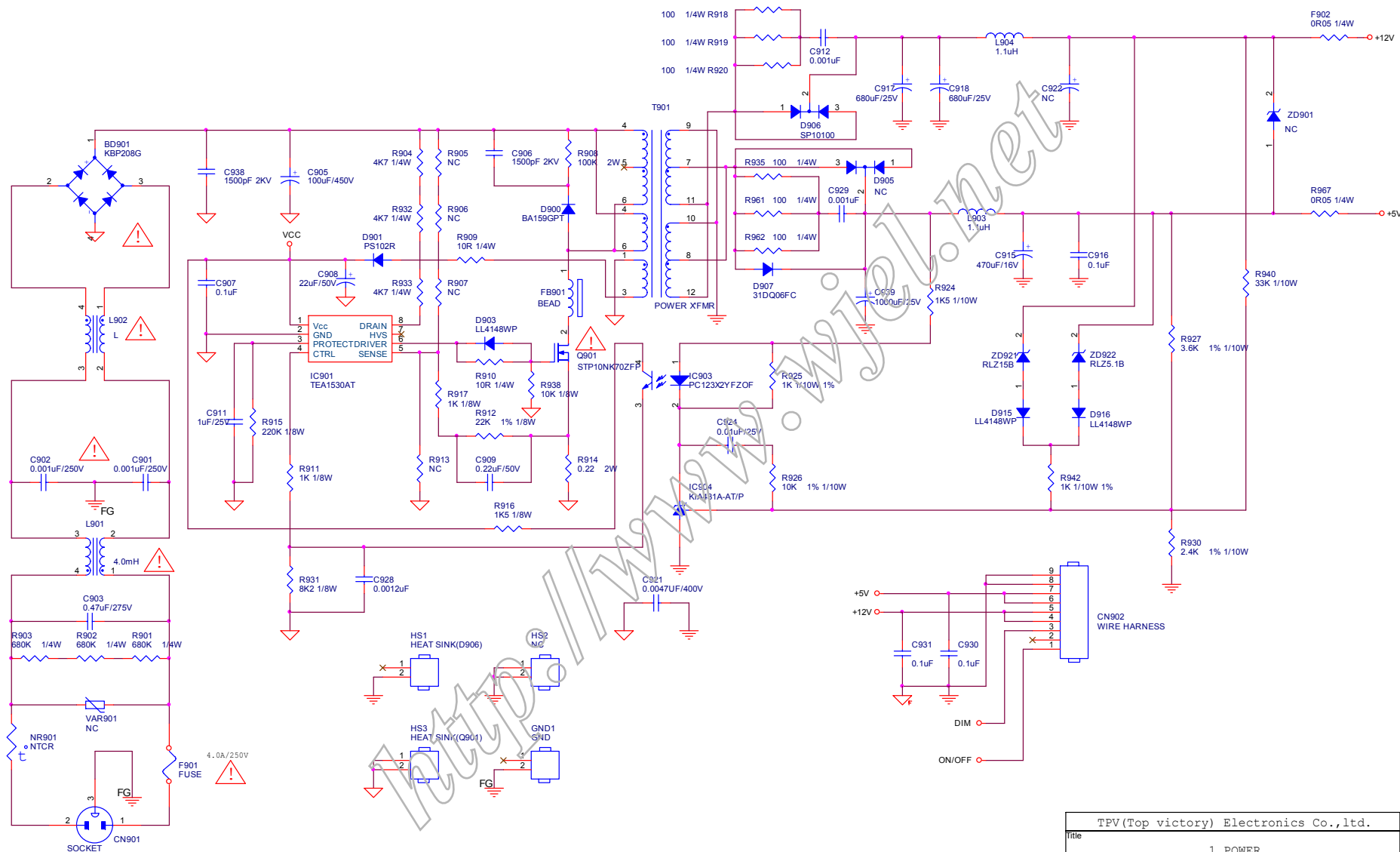

TPV(Top victory) Electronics Co.,ltd.		
Title	1.POWER	
Size B	Document Number <Doc>	Rev D
	715G2538-1	
Date:	Wednesday, March 28, 2007	Sheet 1 of 2

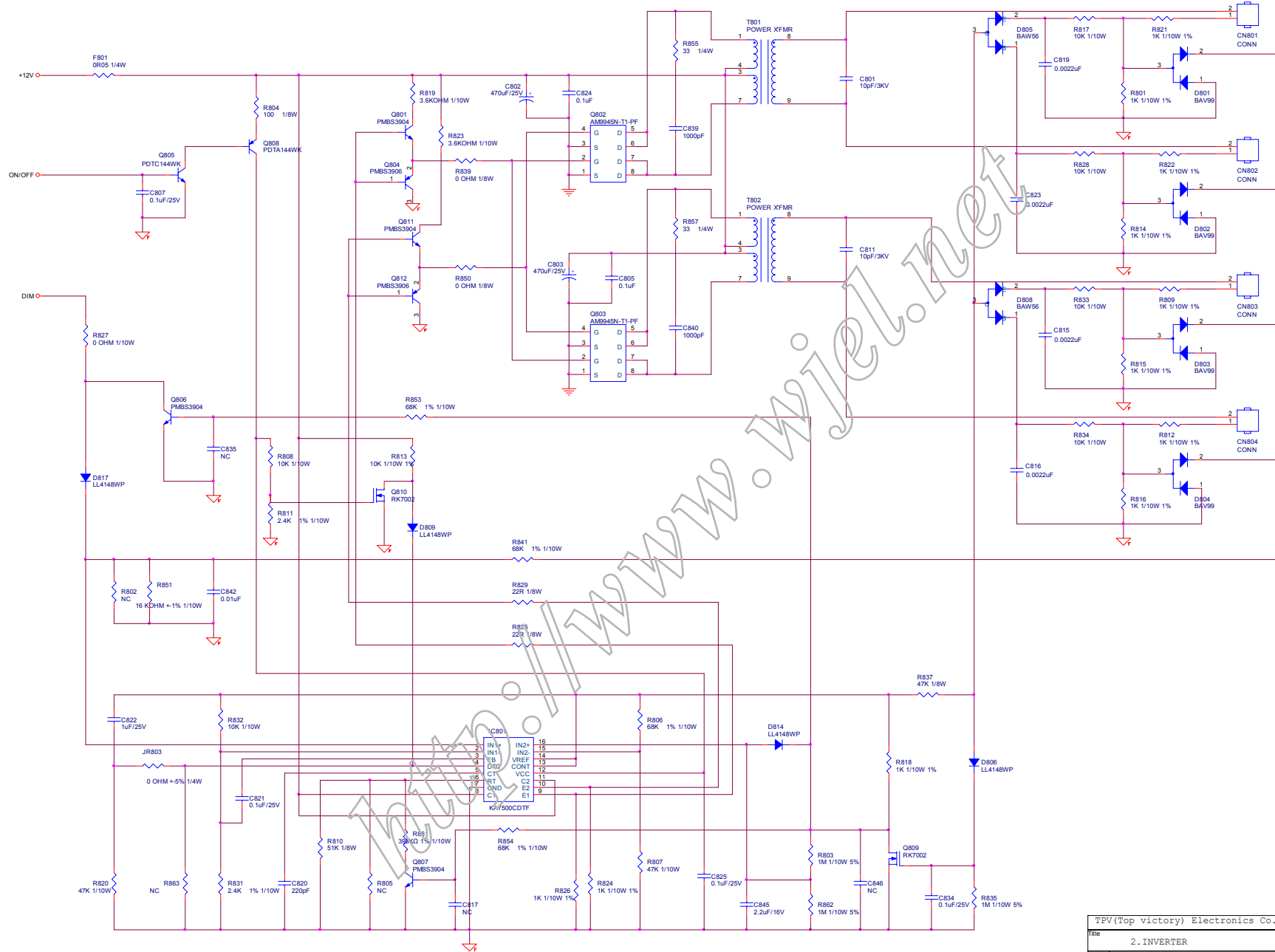

TPV(Top victory) Electronics Co.,ltd.		
Title 2. INVERTER		
Size	Document Number	Rev
CustomDoc	715G2538-1	D
Date	Wednesday, March 28, 2007	Sheet 1 of 2

6.3 Audio Board

715G2098-1ASU

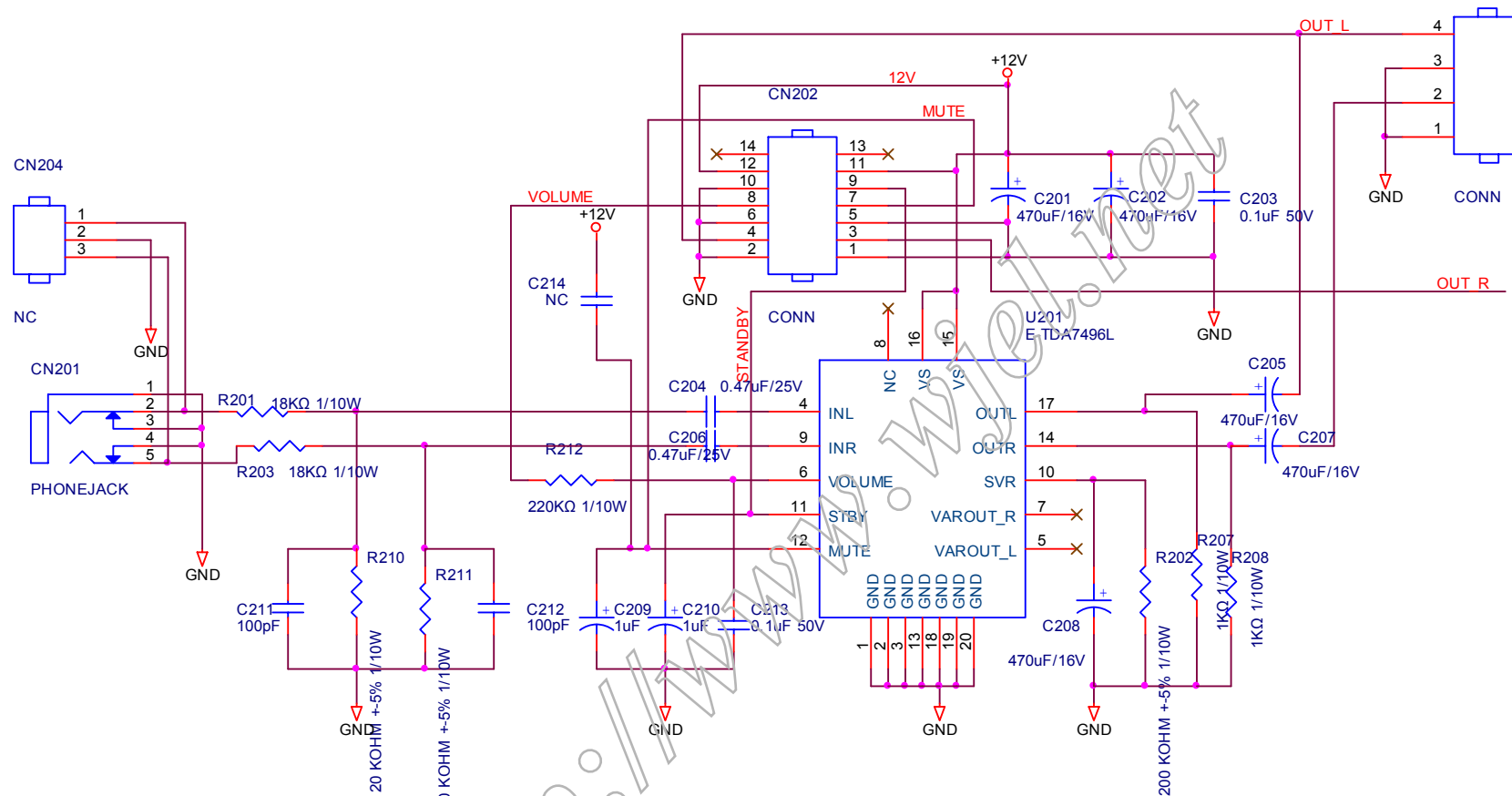

Title		
Audio		
Size A	Document Number 715G2098-1ASU	Rev 1
Date:	Wednesday, January 10, 2007	Sheet 1 of 1

7. PCB Layout

7.1 Main Board

715G2571-1-2

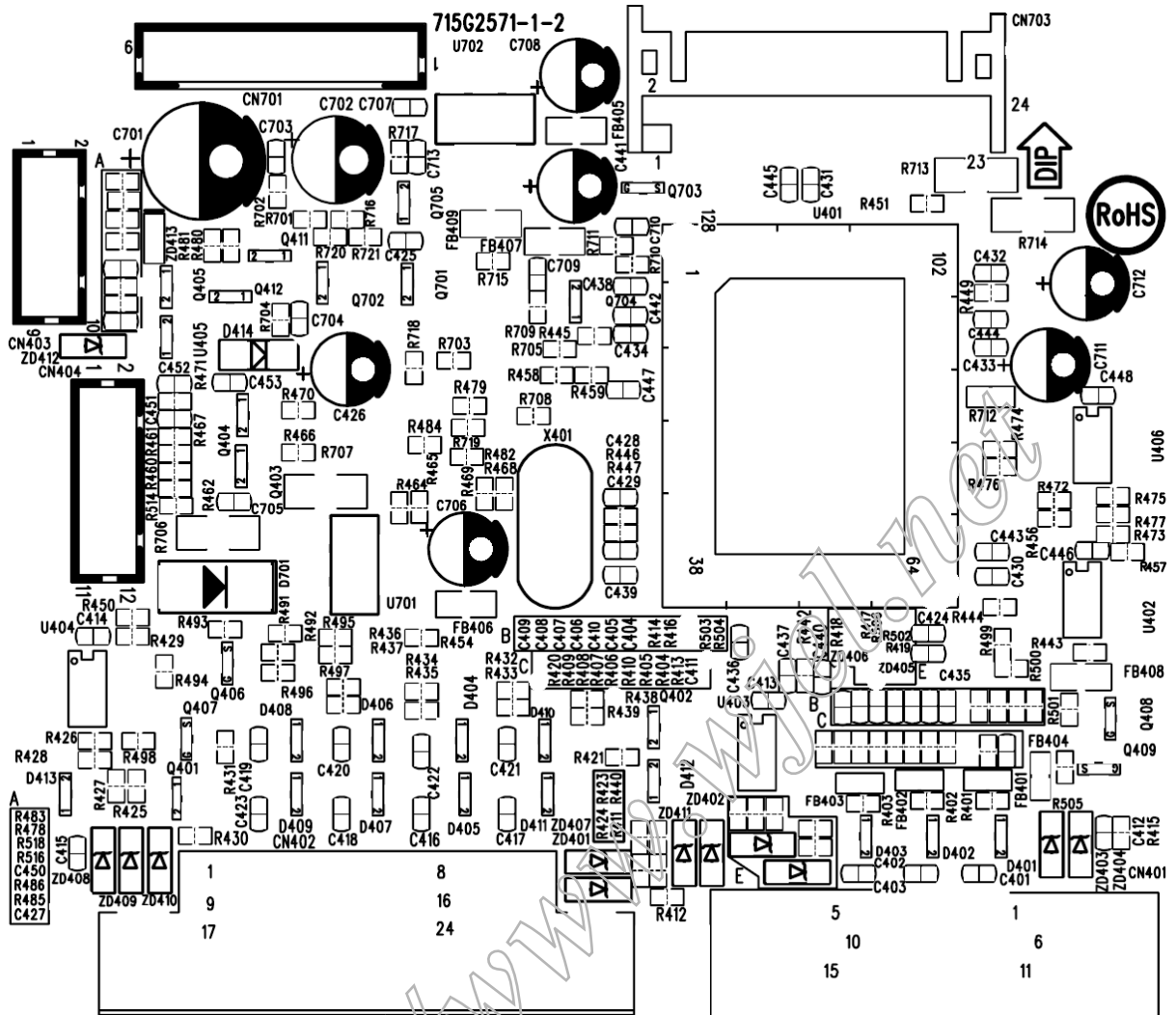

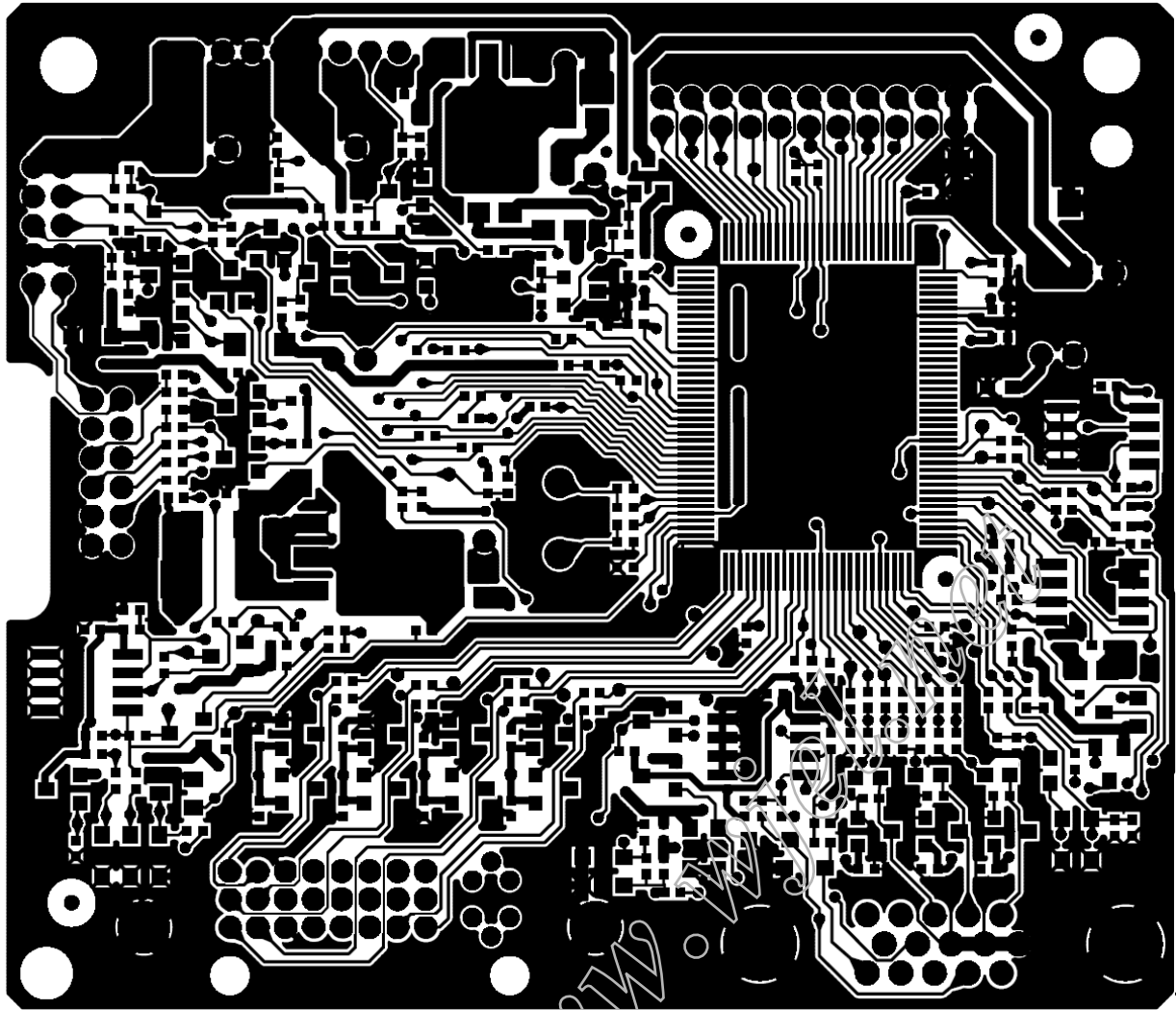

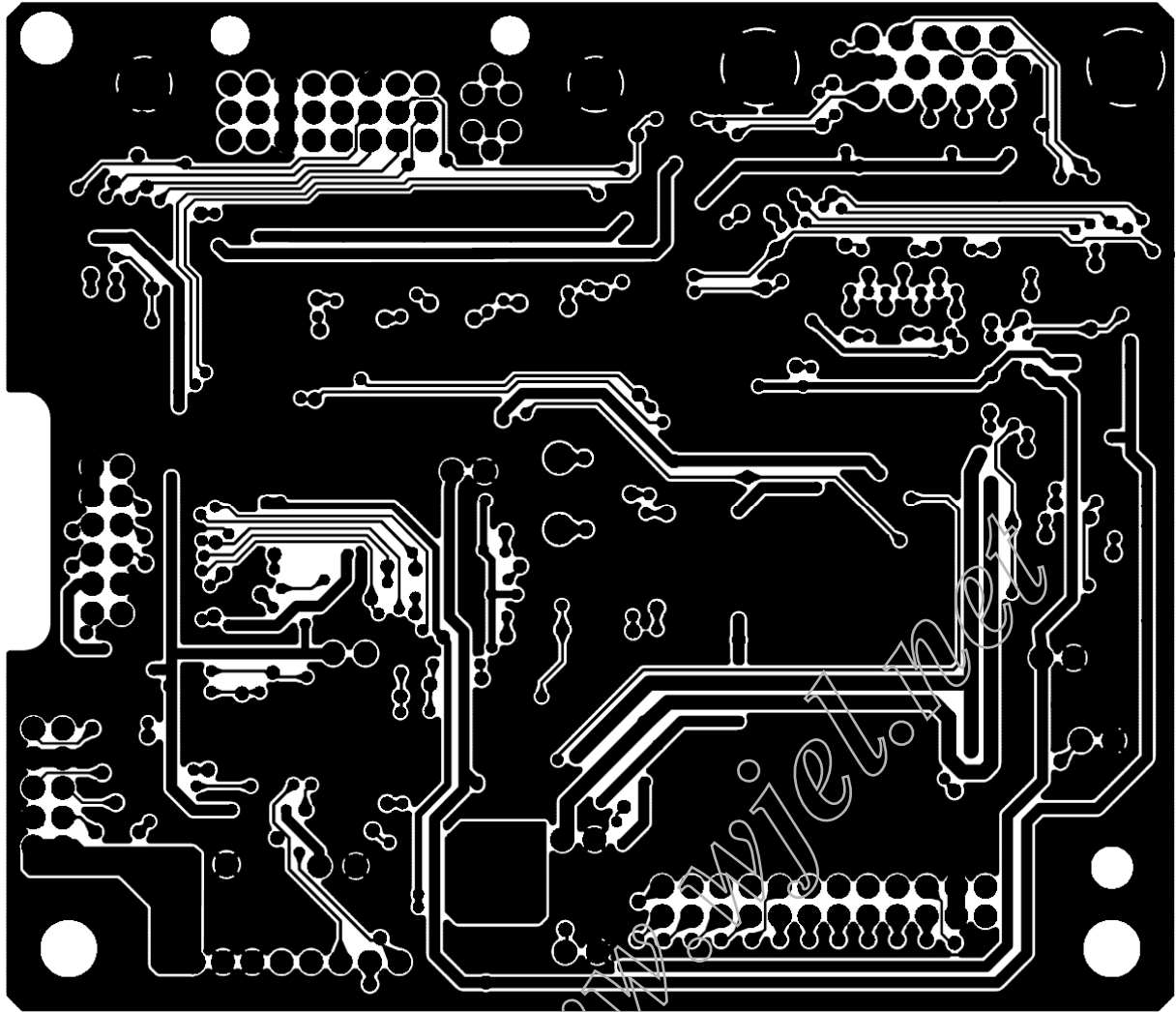

7.2 Power Board

715G2538-1

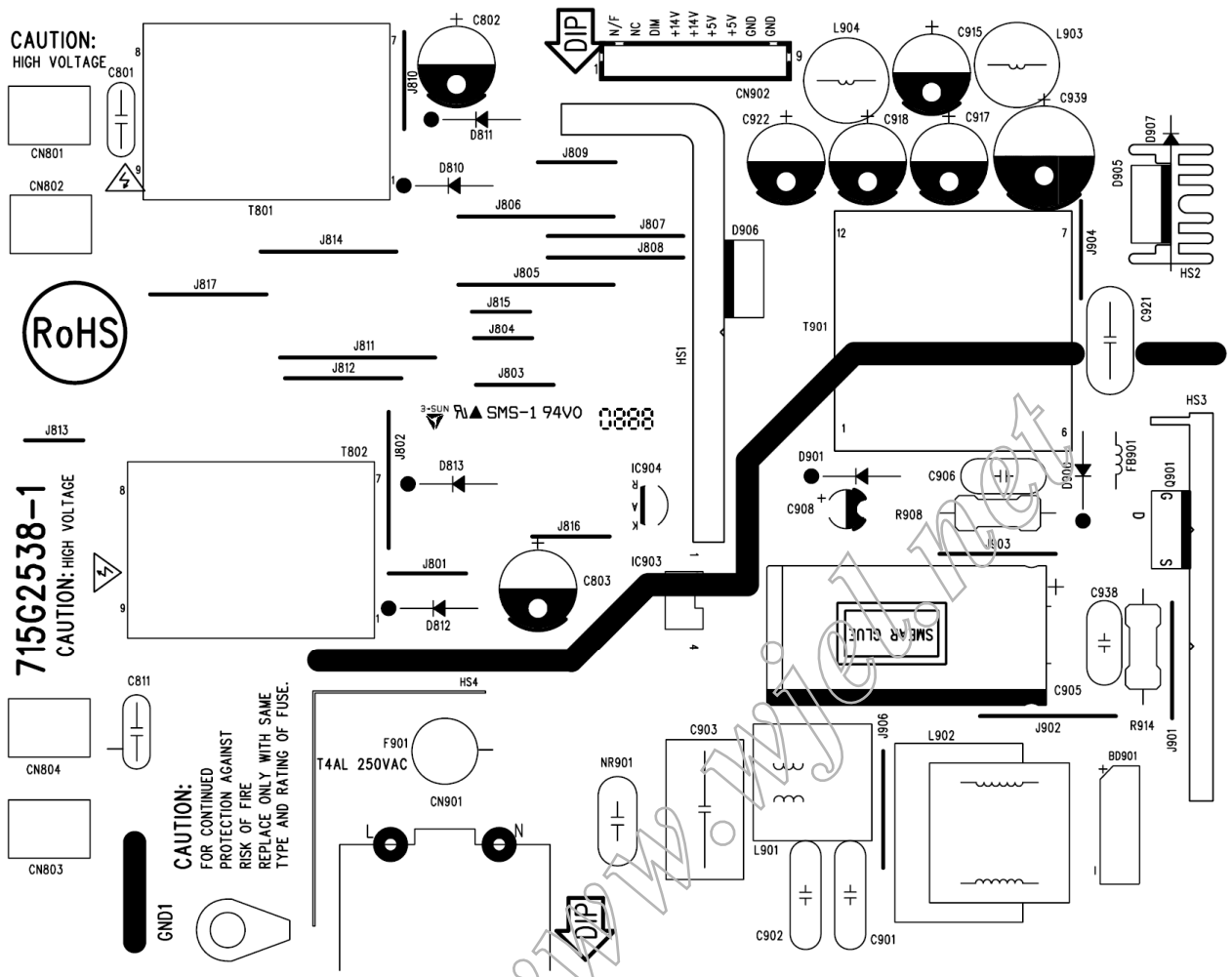

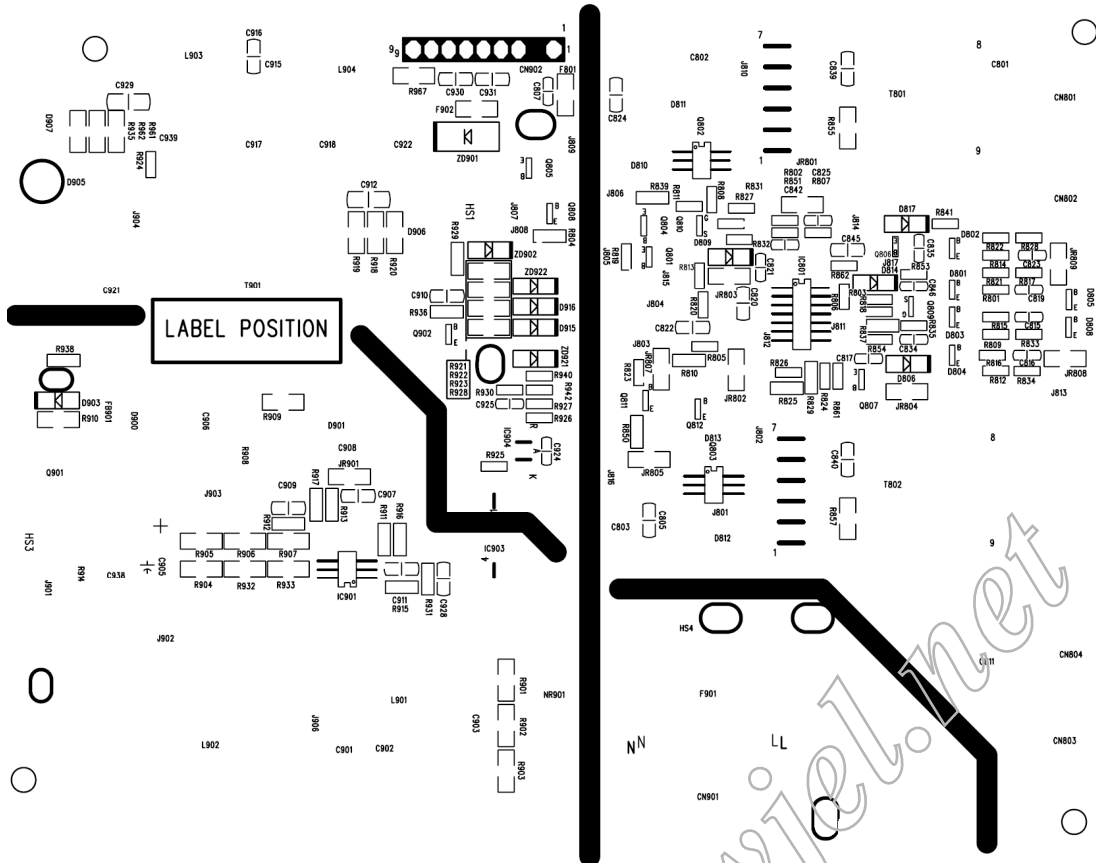

715G2538-1

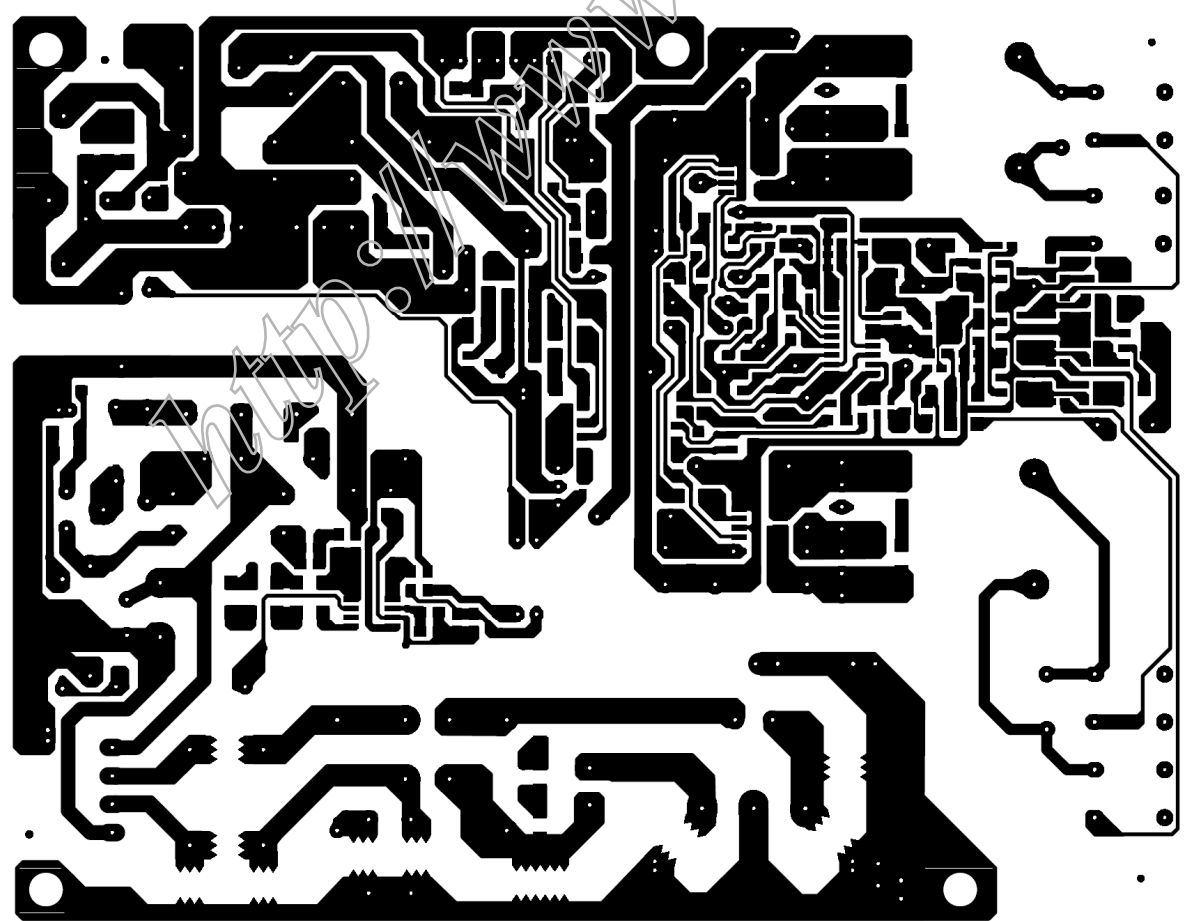

7.3 Audio Board

715G2098-1ASU

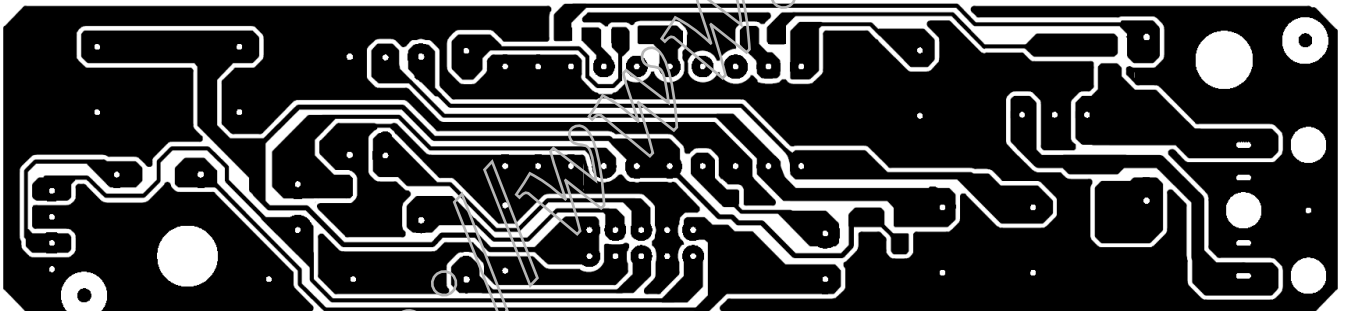
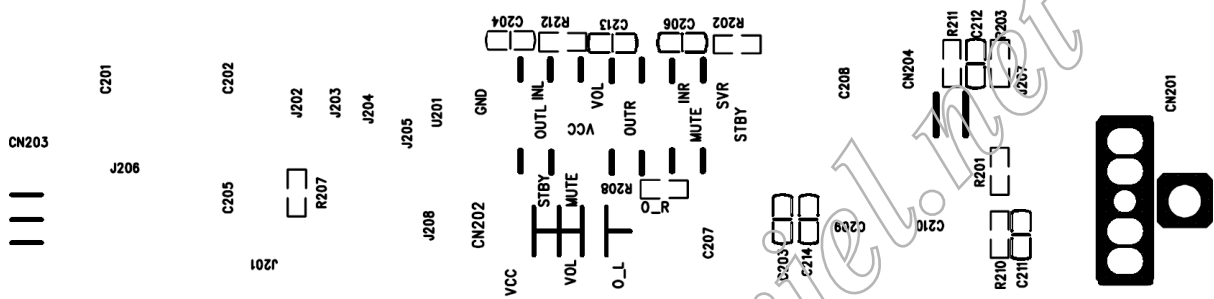
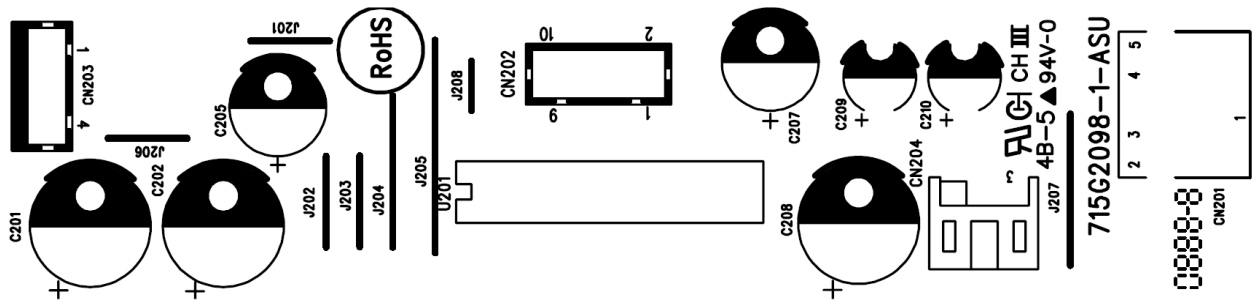

7.4 Key Board

715G2546-1

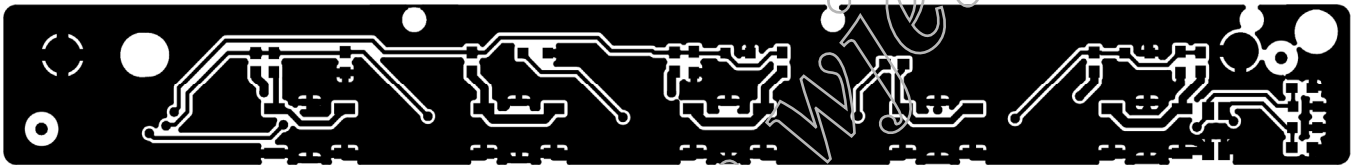
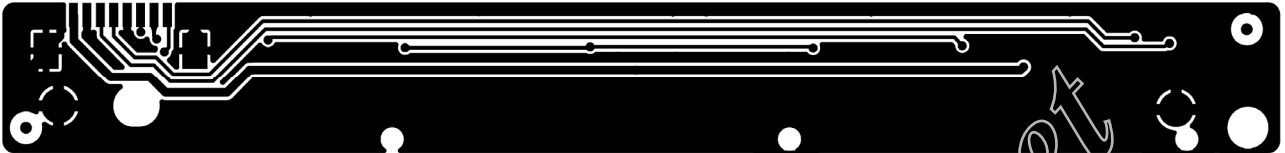
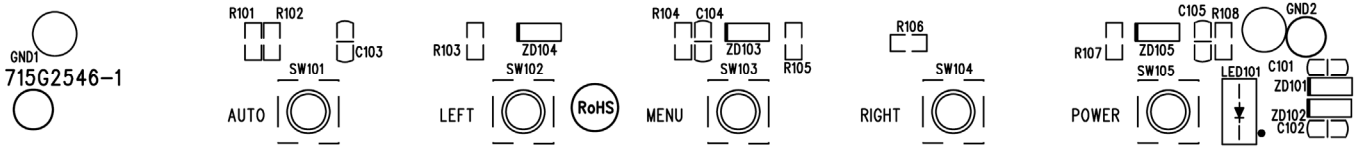

<http://www.wiel.net>

8. Maintainability

8.1 Equipments And Tools Requirement

1. Voltmeter.
2. Oscilloscope.
3. Pattern Generator.
4. DDC Tool with an IBM Compatible Computer.
5. Alignment Tool.
6. LCD Color Analyzer.
7. Service Manual.
8. User Manual.

<http://www.wjel.net>

8.2 Trouble Shooting

8.2.1 Main Board

(1). No Power

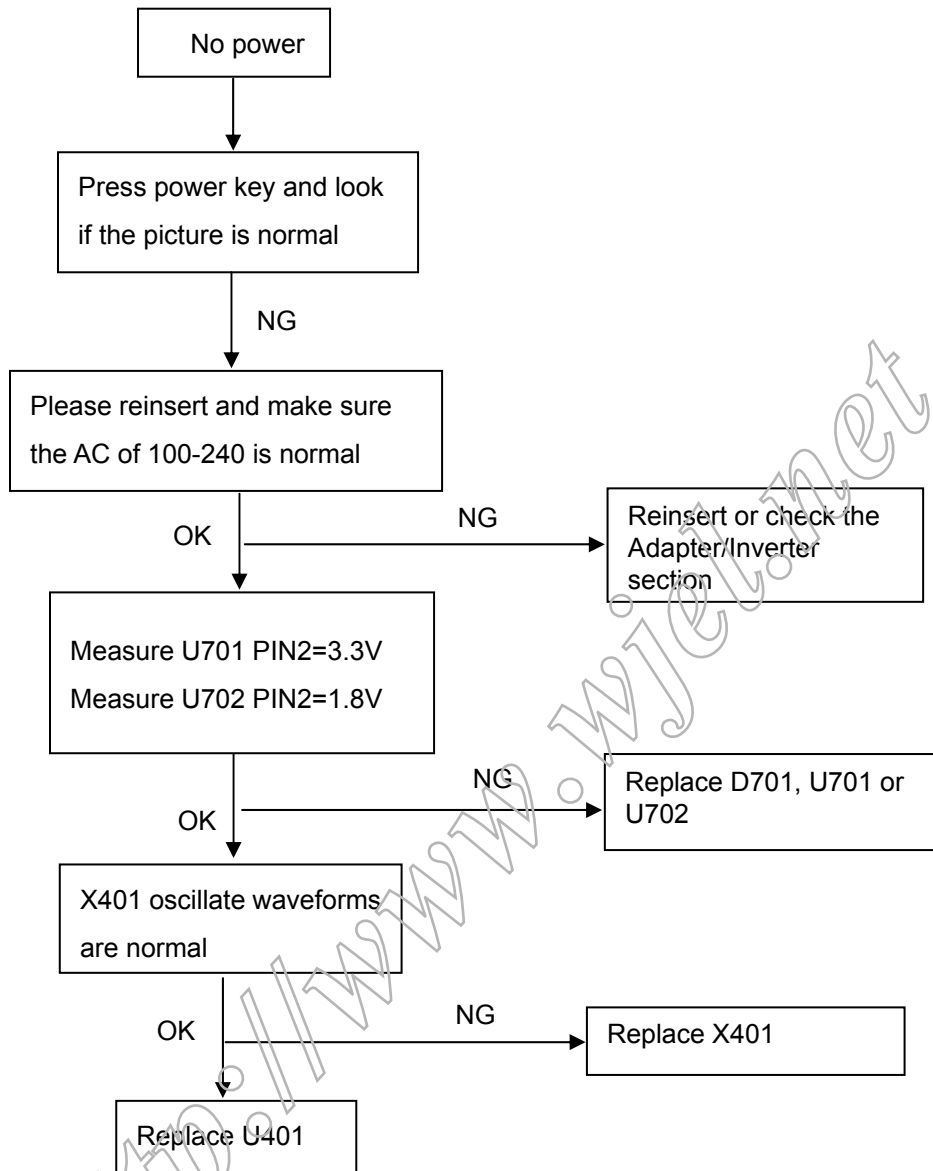

(2). No Picture

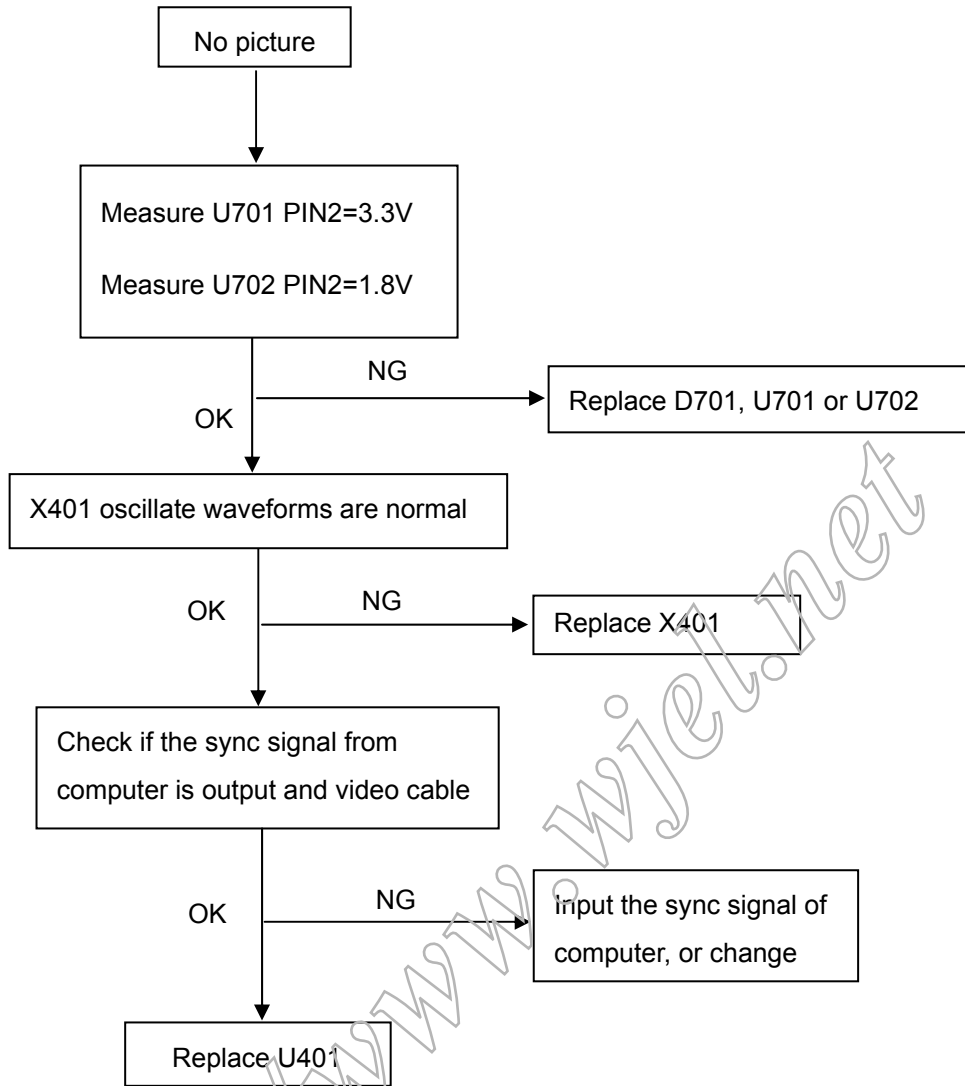

(3). White screen

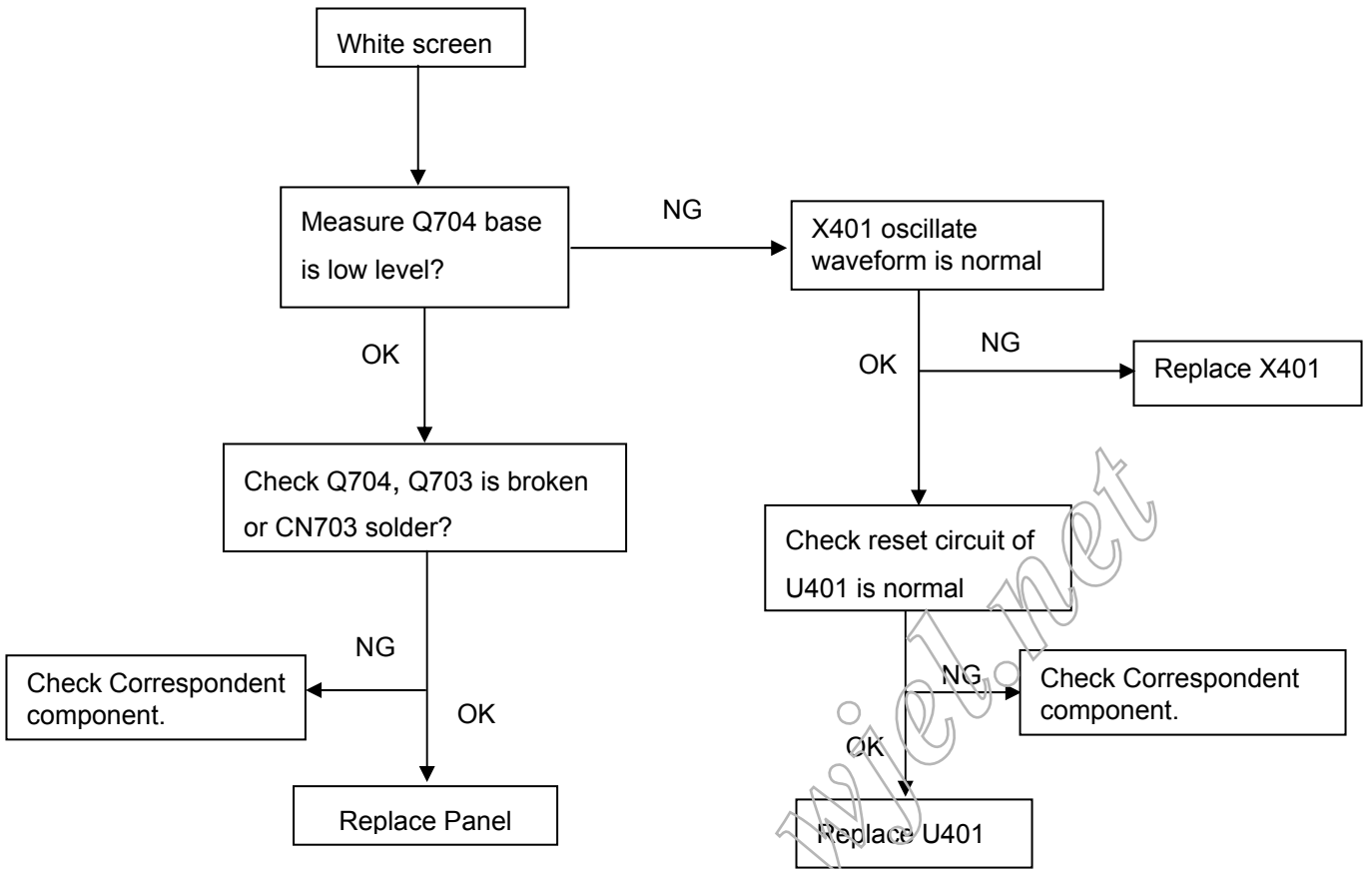

8.2.2 Power/Inverter Board

1.) No power

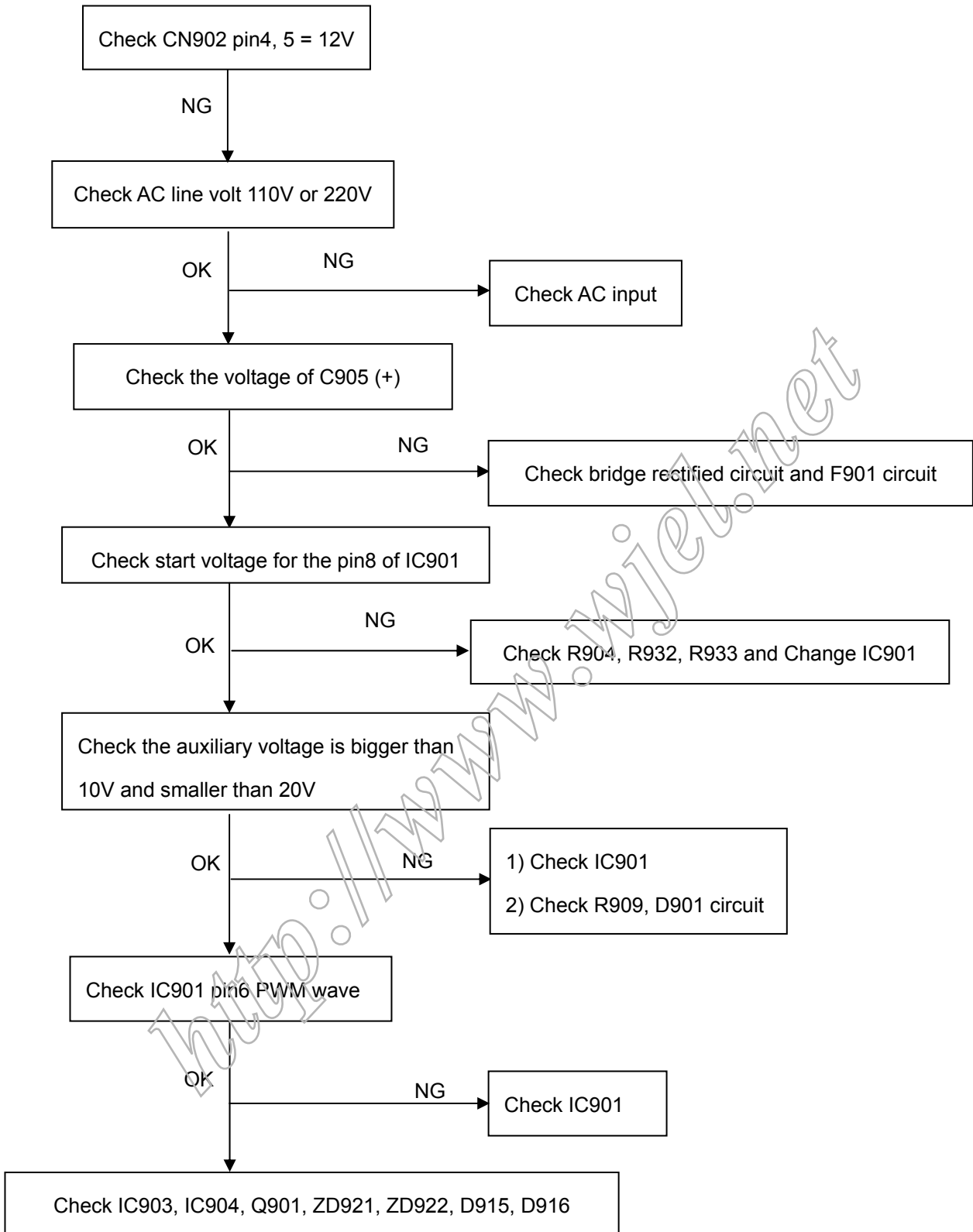

2.) W / LED, No Backlight

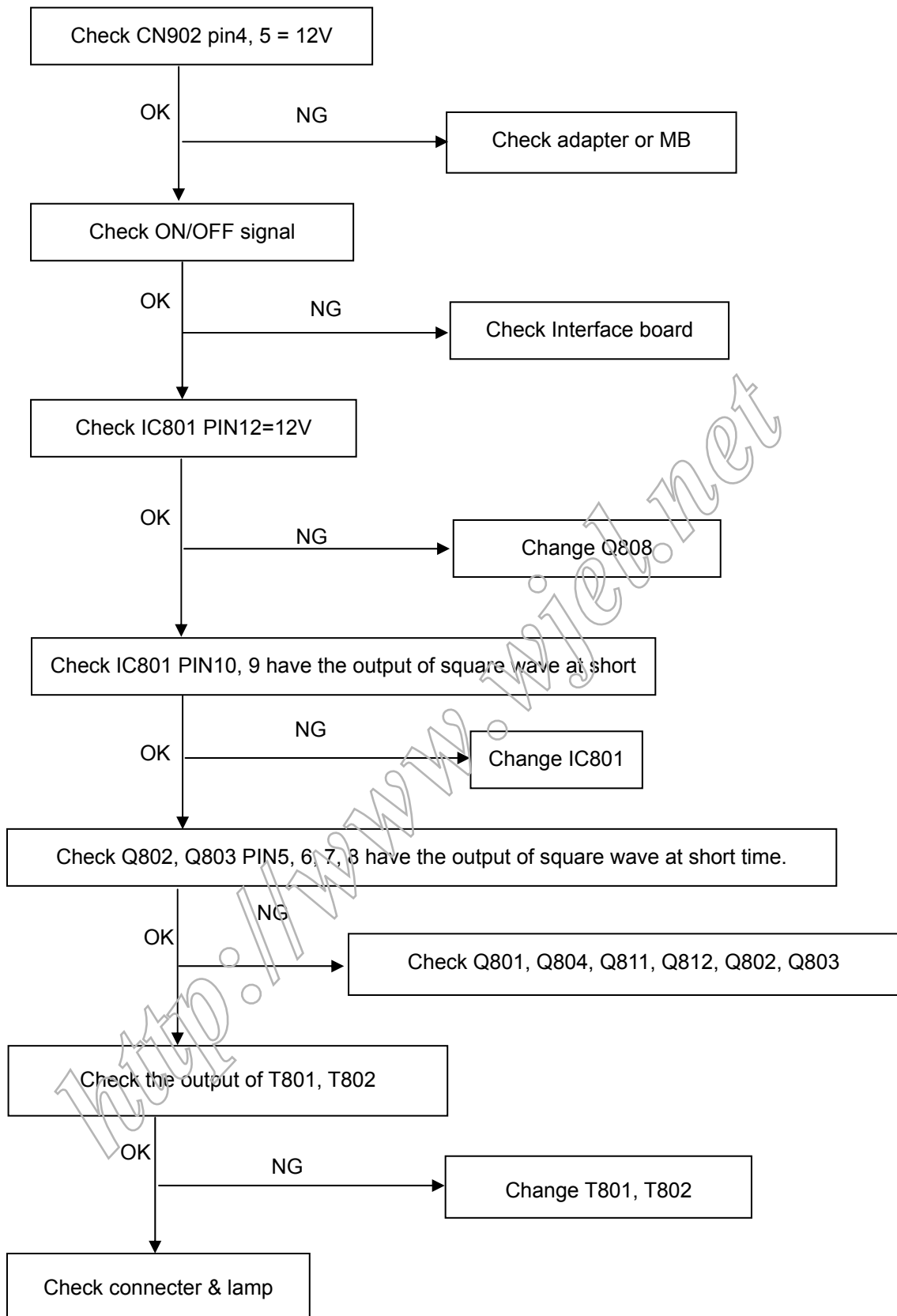

8.2.3 Key Board

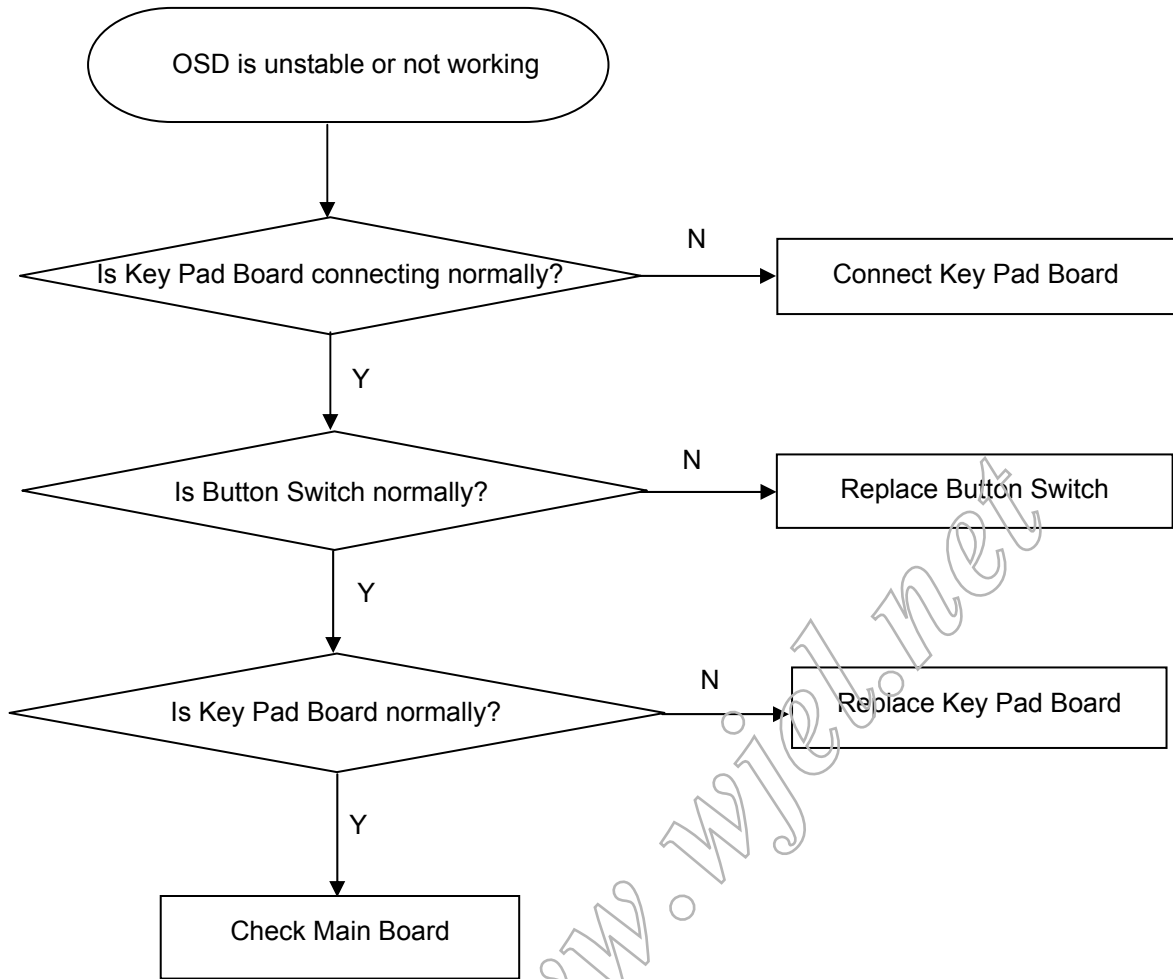

<http://www.wjcl.net>

9. White- Balance, Luminance Adjustment

Approximately 30 minutes should be allowed for warm up before proceeding white balance adjustment.

Before started adjust white balance , please set the Chroma-7120 MEM Channel 3 to Warm (6500K) color, MEM Channel 4 to Normal (7500K) color, MEM Channel 9 to Cool (9300K) color , and MEM Channel 10 to sRGB color (our Warm color parameter is $x = 313 \pm 20$, $y = 329 \pm 20$, $Y \geq 180 \text{cd/m}^2$; Normal color parameter is $x = 299 \pm 20$, $y = 315 \pm 20$, $Y \geq 180 \text{cd/m}^2$; Cool color parameter is $x = 283 \pm 20$, $y = 297 \pm 20$, $Y \geq 160 \text{cd/m}^2$; sRGB color parameter is $x = 313 \pm 20$, $y = 329 \pm 20$, $Y = 150 \pm 15 \text{cd/m}^2$)

How to setting MEM channel you can reference to chroma 7120 user guide or simple use " SC" key and " NEXT" Key to modify xyY value and use "ID" key to modify the TEXT description Following is the procedure to do white-balance adjust .

2. Setting the color temp. you want

A. MEM.CHANNEL 3 (Warm color):

Warm color temp. parameter is $x = 313 \pm 20$, $y = 329 \pm 20$, $Y \geq 180 \text{cd/m}^2$

B. MEM.CHANNEL 4 (Normal color):

Normal color temp. parameter is $x = 299 \pm 20$, $y = 315 \pm 20$, $Y \geq 180 \text{cd/m}^2$

C. MEM.CHANNEL 9(Cool color):

Cool color temp. parameter is $x = 283 \pm 20$, $y = 297 \pm 20$, $Y \geq 160 \text{cd/m}^2$

D. MEM.CHANNEL 10 (sRGB color):

sRGB color temp. parameter is $x = 313 \pm 20$, $y = 329 \pm 20$, $Y = 150 \pm 15 \text{cd/m}^2$

3. Into Factory mode of ASUS VB191T&VB191S:

Press the MENU button, pull out the power cord, and then plug the power cord. Then the factory OSD will be at the left top of the panel.

4. Bias adjustment:

Set the **Contrast**  to 50; Adjust the **Brightness**  to 80.

5. Gain adjustment:

Move cursor to "-F-" and press MENU key

A. Adjust Warm (6500K) color-temperature

1. Switch the chroma-7120 to **RGB-Mode** (with press "MODE" button)
2. Switch the MEM.channel to Channel 3 (with up or down arrow on chroma 7120)
3. The LCD-indicator on chroma 7120 will show $x = 313 \pm 20$, $y = 329 \pm 20$, $Y \geq 180 \text{cd/m}^2$
4. Adjust the RED of color3 on factory window until chroma 7120 indicator reached the value R=100
5. Adjust the GREEN of color3 on factory window until chroma 7120 indicator reached the value G=100
6. Adjust the BLUE of color3 on factory window until chroma 7120 indicator reached the value B=100
7. Repeat above procedure (item 4,5,6) until chroma 7120 RGB value meet the tolerance = 100 ± 2

B. Adjust Normal (7500K) color-temperature

1. Switch the chroma-7120 to **RGB-Mode** (with press "MODE" button)
2. Switch the MEM.channel to Channel 4(with up or down arrow on chroma 7120)
3. The LCD-indicator on chroma 7120 will show $x = 299 \pm 20$, $y = 315 \pm 20$, $Y \geq 180 \text{cd/m}^2$
4. Adjust the RED of color3 on factory window until chroma 7120 indicator reached the value R=100

5. Adjust the GREEN of color3 on factory window until chroma 7120 indicator reached the value $G=100$
 6. Adjust the BLUE of color3 on factory window until chroma 7120 indicator reached the value $B=100$
 7. Repeat above procedure (item 4,5,6) until chroma 7120 RGB value meet the tolerance $=100\pm 2$
- C. Adjust Cool (9300K) color-temperature
1. Switch the Chroma-7120 to **RGB-Mode** (with press "MODE" button)
 2. Switch the MEM. Channel to Channel 9 (with up or down arrow on chroma 7120)
 3. The LCD-indicator on chroma 7120 will show $x = 283 \pm 20$, $y = 297 \pm 20$, $Y \geq 160 \text{cd/m}^2$
 4. Adjust the RED of color1 on factory window until chroma 7120 indicator reached the value $R=100$
 5. Adjust the GREEN of color1 on factory window until chroma 7120 indicator reached the value $G=100$
 6. Adjust the BLUE of color1 on factory window until chroma 7120 indicator reached the value $B=100$
 7. Repeat above procedure (item 4,5,6) until chroma 7120 RGB value meet the tolerance $=100\pm 2$
- D. Adjust sRGB color-temperature
1. Switch the chroma-7120 to **RGB-Mode** (with press "MODE" button)
 2. Switch the MEM.channel to Channel 10 (with up or down arrow on chroma 7120)
 3. The LCD-indicator on chroma 7120 will show $x = 313 \pm 20$, $y = 329 \pm 20$, $Y = 150 \pm 15 \text{cd/m}^2$
 4. Adjust the RED of color3 on factory window until chroma 7120 indicator reached the value $R=100$
 5. Adjust the GREEN of color3 on factory window until chroma 7120 indicator reached the value $G=100$
 6. Adjust the BLUE of color3 on factory window until chroma 7120 indicator reached the value $B=100$
 7. Repeat above procedure (item 4,5,6) until chroma 7120 RGB value meet the tolerance $=100\pm 2$
- E. Turn the Power-button off to quit from factory mode.

10. Monitor Exploded View

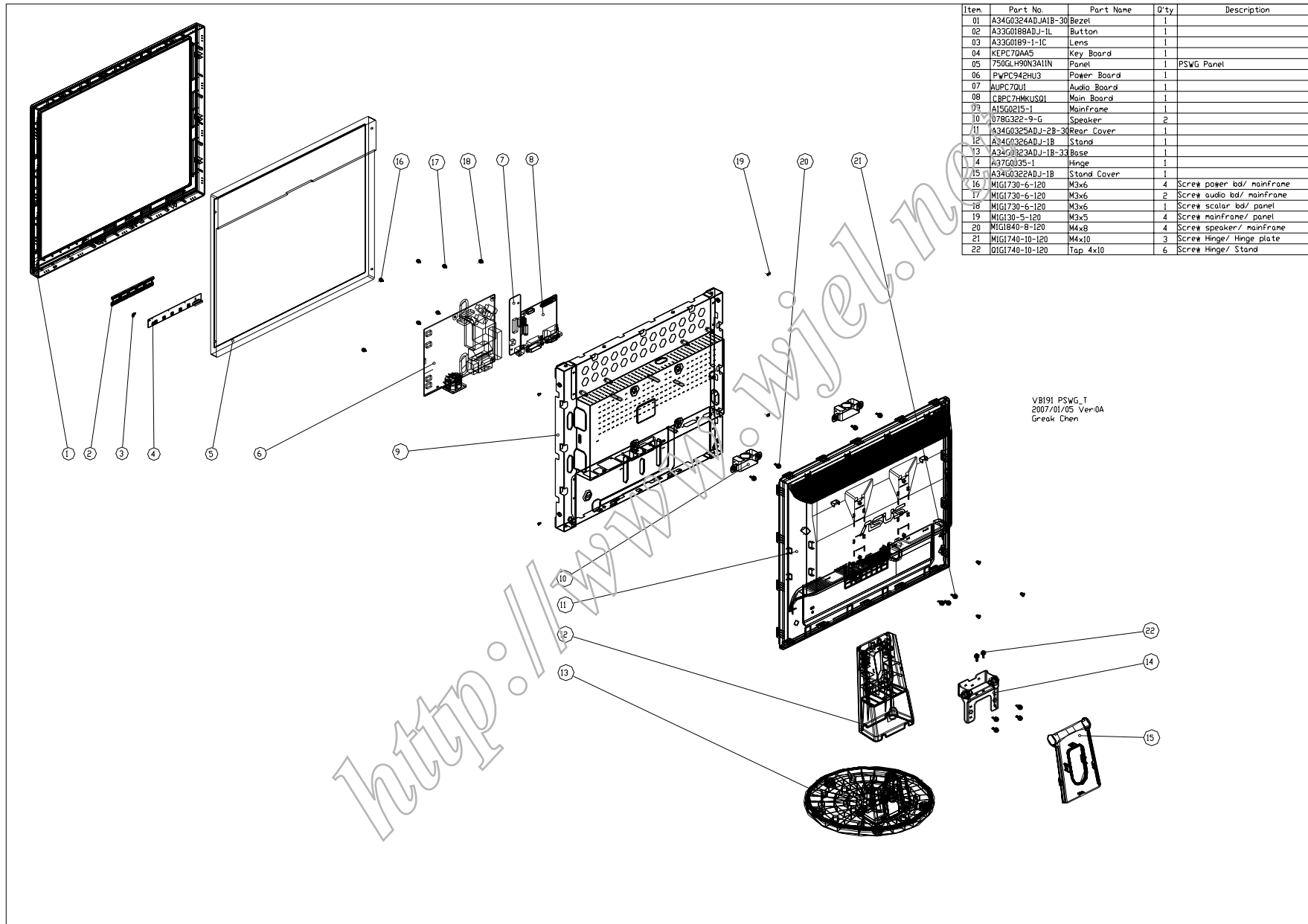

Item	Part No.	Part Name	Q'ty	Description
01	A34G03E4ADJA1B-30	Bezel	1	
02	A33G018ADJ-IL	Button	1	
03	A33G018-1-1C	Lens	1	
04	KEPC70AA5	Key Board	1	
05	750GLH90N3A11N	Panel	1	PSWG Panel
06	PwPC942HU3	Power Board	1	
07	AUPC70U1	Audio Board	1	
08	CRPC7HMKUSD1	Main Board	1	
09	A15G0215-1	Mainframe	1	
10	079G322-9-G	Speaker	2	
11	A34G03E5ADJ-2B-30	Rear Cover	1	
12	A34G03E6ADJ-1B	Stand	1	
13	A34G03E3ADJ-1B-33	Base	1	
14	A37G0025-1	Hinge	1	
15	A34G03E2ADJ-1B	Stand Cover	1	
16	MIG1730-6-120	M3x6	4	Screw power bd/ mainframe
17	MIG1730-6-120	M3x6	2	Screw audio bd/ mainframe
18	MIG1730-6-120	M3x6	1	Screw scalar bd/ panel
19	MIG130-5-120	M3x5	4	Screw mainframe/ panel
20	MIG1840-8-120	M4x8	4	Screw speaker/ mainframe
21	MIG1740-10-120	M4x10	3	Screw Hinge/ Hinge plate
22	OIG1740-10-120	Tap 4x10	6	Screw Hinge/ Stand

VB191 PSWG.T
2007/01/05 Ver-0A
Greak Chen

11. BOM List

For VB191T

T97HMKDBHGUED

Location	Part No.	Description
	040G 457834 4A GP	S/N LABEL FOR ID
	040G 457842 2B	PALLET LABEL
	040G 581680 1A	WARRANTY LABEL
	040G 582680 3A	PALLET LABEL
	040G 582680 4A	CARTON LABEL
	041G780061537A	TCO'03 CARD
	044G9003202	CORNER PAPER
	044GH600 1	HANDLE2
	050G 600 4	HANDLE 1
	052G 1186	SMALL TAPE
	052G 1211 A	165MINIUM TAPE
	052G6020 5	PROTECT FILM
E089D	089G 17356X554	AUDIO CABLE
E089	089G 728CAA D1	SIGNAL CABLE D-SUB COMLINK
E089C	089G1748LAADV1	SIGNAL CABLE DVI GOLDFULL
E089B	089G404A18N YH	POWER CABLE
E089A	089G410A18N IS	POWER CORD WALL-OUT FOR UK
	095G801412D 80	HARNESS 8P-12P 360MM
	095G801830D154	HARNESS 30P-24P 200MM
	0M1G 130 5120	SCREW
	0M1G 930 5 47 CR3	SCREW
	0M1G1730 6120	SCREW
	0M1G1730 6120	SCREW
	0M1G1730 6120	SCREW
	705GQ734090	STAND ASS'Y(19")
	0Q1G1740 10120	SCREW
	A34G0326ADJ 1B	STAND
	A37G0037 2	HINGE
	705GQ734092	MAIN FRAME ASS'Y(19")
	078G 322 9 G	SPEAKER 8 OHM 1.5W L:230 MM 43X18MM
	0M1G1840 8120	SCREW
	A15G0215 1	MAINFRAME
E750L	750GLH90N3A11N	PANEL HSD190MEN3-A 19" HANNSTAR
	A33G0188ADJ 1L	BUTTON FUNC
	A33G0189 1 1C	LENS POWER
	A34G0323ADJ 1B 33	BASE

	A34G0324ADJA1B 30	BEZEL L19A-7ASUS
	A34G0325ADJ 2B 30	REAR COVER(19)
	A34G0327ADJ 1B	STAND_COVER
	AM1G1740 10120	SCREW(M4*8)
	AUPC7QU1	AUDIO BOARD
CN203	033G3802 4	WAFER EH-4
CN202	033G802410C H	CONNECTOR
U201	056G 616 1	IC E-TDA7496L ST
C205	067G215B471 3N GP	KY16VB470M-L 8*15MM
C207	067G215B471 3N GP	KY16VB470M-L 8*15MM
C208	067G215V471 3N GP	KY16VB470M-CC3 10*12.5
C202	067G215V471 4N GP	KY25VB470M-CC3 10*16
C201	067G215V471 4N GP	KY25VB470M-CC3 10*16
CN201	088G 30210K E	PHONE JACK 5PIN
	090G6093 1	HEAT SINK
R208	061G0603102	RST CHIP 1K 1/10W 5%
R207	061G0603102	RST CHIP 1K 1/10W 5%
R203	061G0603183	RST CHIPR 18 KOHM +-5% 1/10W
R201	061G0603183	RST CHIPR 18 KOHM +-5% 1/10W
R211	061G0603203	RST CHIPR 20 KOHM +-5% 1/10W
R210	061G0603203	RST CHIPR 20 KOHM +-5% 1/10W
R202	061G0603204	RST CHIPR 200 KOHM +-5% 1/10W
R212	061G0603224	RST CHIPR 220 KOHM +-5% 1/10W
C211	065G0603101 31	CER1 0603 NP0 50V 100P PM5 R
C212	065G0603101 31	CER1 0603 NP0 50V 100P PM5 R
C213	065G0603104 32	CHIP 0.1UF 50V X7R
C203	065G0603104 32	CHIP 0.1UF 50V X7R
C206	065G0603474 27	CHIP 0.47UF 25V Y5V
C204	065G0603474 27	CHIP 0.47UF 25V Y5V
C209	067G 2151097NT	KMY50VB1M-TP5 5*11.5
C210	067G 2151097NT	KMY50VB1M-TP5 5*11.5
	715G2098 1ASU	AUDIO-BOARD PCB
	CBPC7HMKUSQ1	MAIN BOARD
CN701	033G3802 9	WAFER 9P RIGHT ANELE PITCH
CN403	033G801710A BH	CONNECTOR
CN404	033G8027 12	WAFER 2*6P 2.0MM R/A
CN703	033G8027 24 H	CONN W TO B12P*2 P*2.0 4505-2
	040G 457624 1B	LABEL-CPU
	040G 45762412B	CBPC LABEL
C702	067G215V101 4N	KY25VB100M-CC3(6.3*11)

C701	067G215V101 7P	CAP L105°C 100UF M 50V JIANGHAI
C441	067G215Y100 7N	KY50VB10M-L 5*11
C708	067G215Y100 7N	KY50VB10M-L 5*11
C426	067G215Y100 7N	KY50VB10M-L 5*11
C706	067G215Y100 7N	KY50VB10M-L 5*11
C711	067G215Y100 7N	KY50VB10M-L 5*11
C712	067G215Y2207NV	KY50VB22M-CC3 5*11
CN401	088G 35315F H	D-SUB 15PIN
CN402	088G 35424F C	DVI 24PIN CONN F
X401	093G 2253B J	14.31818MHZ/85C
U401	056G 562151	IC TSUM56AWHK-LF PQFP-128
U702	056G 563 27	IC AIC1117A-18PYTR-R SOT223
U701	056G 585 4	IC AIC1117-33PYTR-R AIC
U404	056G1133 34	M24C02-WMN6TP
U403	056G1133 34	M24C02-WMN6TP
U406	056G1133 56	M24C16-WMN6TP
U402	056G1133713	IC PM25LV010A-100SCE SOIC-8
Q702	057G 417 4	PMBS3904/PHILIPS-SMT(04)
Q701	057G 417 4	PMBS3904/PHILIPS-SMT(04)
Q405	057G 417 4	PMBS3904/PHILIPS-SMT(04)
Q402	057G 417 4	PMBS3904/PHILIPS-SMT(04)
Q401	057G 417 4	PMBS3904/PHILIPS-SMT(04)
Q403	057G 417 6	PMBS3906/PHILIPS-SMT(06)
Q404	057G 417 6	PMBS3906/PHILIPS-SMT(06)
Q704	057G 417 6	PMBS3906/PHILIPS-SMT(06)
Q412	057G 417 12 T	KEC 2N3904S-RTK/PS
Q411	057G 417 12 T	KEC 2N3904S-RTK/PS
Q406	057G 758 1	2N7002ESOT23 SILICONIX
Q407	057G 758 1	2N7002ESOT23 SILICONIX
Q408	057G 758 1	2N7002ESOT23 SILICONIX
Q409	057G 758 1	2N7002ESOT23 SILICONIX
Q703	057G 763 1	A03401 SOT23 BY AOS(A1)
R439	061G0402100	RST CHIPR 10 OHM +-5% 1/16W
R438	061G0402100	RST CHIPR 10 OHM +-5% 1/16W
R437	061G0402100	RST CHIPR 10 OHM +-5% 1/16W
R436	061G0402100	RST CHIPR 10 OHM +-5% 1/16W
R435	061G0402100	RST CHIPR 10 OHM +-5% 1/16W
R434	061G0402100	RST CHIPR 10 OHM +-5% 1/16W
R433	061G0402100	RST CHIPR 10 OHM +-5% 1/16W
R432	061G0402100	RST CHIPR 10 OHM +-5% 1/16W

R412	061G0402100 1F	RST CHIPR 1KOHM +-1% 1/16W
R476	061G0402101	RST CHIPR 100 OHM +-5% 1/16W
R474	061G0402101	RST CHIPR 100 OHM +-5% 1/16W
R472	061G0402101	RST CHIPR 100 OHM +-5% 1/16W
R462	061G0402101	RST CHIPR 100 OHM +-5% 1/16W
R461	061G0402101	RST CHIPR 100 OHM +-5% 1/16W
R460	061G0402101	RST CHIPR 100 OHM +-5% 1/16W
R409	061G0402101	RST CHIPR 100 OHM +-5% 1/16W
R407	061G0402101	RST CHIPR 100 OHM +-5% 1/16W
R405	061G0402101	RST CHIPR 100 OHM +-5% 1/16W
R414	061G0402102	RST CHIPR 1 KOHM +-5% 1/16W
R416	061G0402102	RST CHIPR 1 KOHM +-5% 1/16W
R440	061G0402102	RST CHIPR 1 KOHM +-5% 1/16W
R485	061G0402102	RST CHIPR 1 KOHM +-5% 1/16W
R516	061G0402102	RST CHIPR 1 KOHM +-5% 1/16W
R518	061G0402102	RST CHIPR 1 KOHM +-5% 1/16W
R720	061G0402102	RST CHIPR 1 KOHM +-5% 1/16W
R465	061G0402102	RST CHIPR 1 KOHM +-5% 1/16W
R469	061G0402102	RST CHIPR 1 KOHM +-5% 1/16W
R477	061G0402103	RST CHIPR 10 KOHM +-5% 1/16W
R486	061G0402103	RST CHIPR 10 KOHM +-5% 1/16W
R704	061G0402103	RST CHIPR 10 KOHM +-5% 1/16W
R708	061G0402103	RST CHIPR 10 KOHM +-5% 1/16W
R710	061G0402103	RST CHIPR 10 KOHM +-5% 1/16W
R445	061G0402103	RST CHIPR 10 KOHM +-5% 1/16W
R718	061G0402103	RST CHIPR 10 KOHM +-5% 1/16W
R479	061G0402103	RST CHIPR 10 KOHM +-5% 1/16W
R482	061G0402103	RST CHIPR 10 KOHM +-5% 1/16W
R475	061G0402103	RST CHIPR 10 KOHM +-5% 1/16W
R473	061G0402103	RST CHIPR 10 KOHM +-5% 1/16W
R458	061G0402103	RST CHIPR 10 KOHM +-5% 1/16W
R457	061G0402103	RST CHIPR 10 KOHM +-5% 1/16W
R451	061G0402103	RST CHIPR 10 KOHM +-5% 1/16W
R449	061G0402103	RST CHIPR 10 KOHM +-5% 1/16W
R444	061G0402103	RST CHIPR 10 KOHM +-5% 1/16W
R430	061G0402103	RST CHIPR 10 KOHM +-5% 1/16W
R429	061G0402103	RST CHIPR 10 KOHM +-5% 1/16W
R421	061G0402103	RST CHIPR 10 KOHM +-5% 1/16W
R459	061G0402203	RST CHIP 20K 1/16W 5%
R480	061G0402203	RST CHIP 20K 1/16W 5%

R481	061G0402203	RST CHIP 20K 1/16W 5%
R446	061G0402220	RST CHIPR 22 OHM +-5% 1/16W
R447	061G0402220	RST CHIPR 22 OHM +-5% 1/16W
R424	061G0402220 1F	RST CHIPR 2.2KOHM +-1% 1/16W
R413	061G0402222	RST CHIPR 2.2 KOHM +-5% 1/16W
R415	061G0402222	RST CHIPR 2.2 KOHM +-5% 1/16W
R456	061G0402223	RST CHIPR 22 KOHM +-5% 1/16W
R470	061G0402241	RST CHIP 240R 1/16W 5%
R466	061G0402241	RST CHIP 240R 1/16W 5%
R442	061G0402390 0F	RST CHIP 390R 1/16W 1%
R478	061G0402392	RST CHIP 3.9K 1/16W 5%
R483	061G0402392	RST CHIP 3.9K 1/16W 5%
R495	061G0402470	RST CHIPR 47 OHM +-5% 1/16W
R498	061G0402470	RST CHIPR 47 OHM +-5% 1/16W
R499	061G0402470	RST CHIPR 47 OHM +-5% 1/16W
R502	061G0402470	RST CHIPR 47 OHM +-5% 1/16W
R506	061G0402470	RST CHIPR 47 OHM +-5% 1/16W
R702	061G0402470	RST CHIPR 47 OHM +-5% 1/16W
R503	061G0402470	RST CHIPR 47 OHM +-5% 1/16W
R494	061G0402470	RST CHIPR 47 OHM +-5% 1/16W
R491	061G0402470	RST CHIPR 47 OHM +-5% 1/16W
R411	061G0402470 1F	RST CHIPR 4.7KOHM +-1% 1/16W
R410	061G0402471	RST CHIPR 470 OHM +-5% 1/16W
R431	061G0402472	RST CHIPR 4.7 KOHM +-5% 1/16W
R464	061G0402472	RST CHIPR 4.7 KOHM +-5% 1/16W
R468	061G0402472	RST CHIPR 4.7 KOHM +-5% 1/16W
R484	061G0402472	RST CHIPR 4.7 KOHM +-5% 1/16W
R492	061G0402472	RST CHIPR 4.7 KOHM +-5% 1/16W
R496	061G0402472	RST CHIPR 4.7 KOHM +-5% 1/16W
R500	061G0402472	RST CHIPR 4.7 KOHM +-5% 1/16W
R504	061G0402472	RST CHIPR 4.7 KOHM +-5% 1/16W
R703	061G0402472	RST CHIPR 4.7 KOHM +-5% 1/16W
R705	061G0402472	RST CHIPR 4.7 KOHM +-5% 1/16W
R709	061G0402472	RST CHIPR 4.7 KOHM +-5% 1/16W
R418	061G0402472	RST CHIPR 4.7 KOHM +-5% 1/16W
R420	061G0402472	RST CHIPR 4.7 KOHM +-5% 1/16W
R426	061G0402472	RST CHIPR 4.7 KOHM +-5% 1/16W
R428	061G0402472	RST CHIPR 4.7 KOHM +-5% 1/16W
R427	061G0402510 Y	RST CHIP 51R 1/16W 5%
R425	061G0402510 Y	RST CHIP 51R 1/16W 5%

R419	061G0402510 Y	RST CHIP 51R 1/16W 5%
R417	061G0402510 Y	RST CHIP 51R 1/16W 5%
R711	061G0402513	RST CHIP 51K 1/16W 5%
R404	061G0402560 9F	RST CHIPR 56 OHM +-1% 1/16W
R406	061G0402560 9F	RST CHIPR 56 OHM +-1% 1/16W
R408	061G0402560 9F	RST CHIPR 56 OHM +-1% 1/16W
R467	061G0402681	RST CHIPR 680 OHM +-5% 1/16W
R471	061G0402681	RST CHIPR 680 OHM +-5% 1/16W
R401	061G0402750 9F	RST CHIP 75 OHM 1/16W 1%
R402	061G0402750 9F	RST CHIP 75 OHM 1/16W 1%
R403	061G0402750 9F	RST CHIP 75 OHM 1/16W 1%
FB401	061G0603000	RST CHIPR 0 OHM +-5% 1/10W
FB402	061G0603000	RST CHIPR 0 OHM +-5% 1/10W
FB403	061G0603000	RST CHIPR 0 OHM +-5% 1/10W
R712	061G0603103	RST CHIPR 10 KOHM +-5% 1/10W
FB405	061G0805000	0 OHM 1/10W
R714	061G1206301	RST CHIPR 300 OHM +-5% 1/4W
R713	061G1206301	RST CHIPR 300 OHM +-5% 1/4W
C453	065G0402102 32	1000PF +-10% 50V X7R
C452	065G0402102 32	1000PF +-10% 50V X7R
C451	065G0402102 32	1000PF +-10% 50V X7R
C424	065G0402104 15	MLCC 0402 0.1UF K 16V X5R
C423	065G0402104 15	MLCC 0402 0.1UF K 16V X5R
C422	065G0402104 15	MLCC 0402 0.1UF K 16V X5R
C421	065G0402104 15	MLCC 0402 0.1UF K 16V X5R
C420	065G0402104 15	MLCC 0402 0.1UF K 16V X5R
C419	065G0402104 15	MLCC 0402 0.1UF K 16V X5R
C418	065G0402104 15	MLCC 0402 0.1UF K 16V X5R
C417	065G0402104 15	MLCC 0402 0.1UF K 16V X5R
C416	065G0402104 15	MLCC 0402 0.1UF K 16V X5R
C415	065G0402104 15	MLCC 0402 0.1UF K 16V X5R
C403	065G0402104 15	MLCC 0402 0.1UF K 16V X5R
C402	065G0402104 15	MLCC 0402 0.1UF K 16V X5R
C710	065G0402104 15	MLCC 0402 0.1UF K 16V X5R
C709	065G0402104 15	MLCC 0402 0.1UF K 16V X5R
C707	065G0402104 15	MLCC 0402 0.1UF K 16V X5R
C705	065G0402104 15	MLCC 0402 0.1UF K 16V X5R
C704	065G0402104 15	MLCC 0402 0.1UF K 16V X5R
C447	065G0402104 15	MLCC 0402 0.1UF K 16V X5R
C446	065G0402104 15	MLCC 0402 0.1UF K 16V X5R

C440	065G0402104 15	MLCC 0402 0.1UF K 16V X5R
C439	065G0402104 15	MLCC 0402 0.1UF K 16V X5R
C438	065G0402104 15	MLCC 0402 0.1UF K 16V X5R
C437	065G0402104 15	MLCC 0402 0.1UF K 16V X5R
C436	065G0402104 15	MLCC 0402 0.1UF K 16V X5R
C401	065G0402104 15	MLCC 0402 0.1UF K 16V X5R
C450	065G0402105 A5	CAP 0402 1UF K 10V X5R
C428	065G0402220 31	CHIP 22PF 50V NPO
C429	065G0402220 31	CHIP 22PF 50V NPO
C434	065G0402221 32	MLCC 0402 CAP 220PF J 50V X7R
C412	065G0402221 32	MLCC 0402 CAP 220PF J 50V X7R
C433	065G0402221 32	MLCC 0402 CAP 220PF J 50V X7R
C425	065G0402224 17	CAP CER 0.22UF -20%-80%
C414	065G0402224 17	CAP CER 0.22UF -20%-80%
C413	065G0402224 17	CAP CER 0.22UF -20%-80%
C448	065G0402224 17	CAP CER 0.22UF -20%-80%
C411	065G0402330 31	33PF +-50% 50V NPO
C432	065G0402330 31	33PF +-50% 50V NPO
C406	065G0402473 12	CHIP 0.047UF 16V X7R
C407	065G0402473 12	CHIP 0.047UF 16V X7R
C435	065G0402473 12	CHIP 0.047UF 16V X7R
C442	065G0402473 12	CHIP 0.047UF 16V X7R
C443	065G0402473 12	CHIP 0.047UF 16V X7R
C444	065G0402473 12	CHIP 0.047UF 16V X7R
C445	065G0402473 12	CHIP 0.047UF 16V X7R
C405	065G0402473 12	CHIP 0.047UF 16V X7R
C404	065G0402473 12	CHIP 0.047UF 16V X7R
C408	065G0402473 12	CHIP 0.047UF 16V X7R
C409	065G0402473 12	CHIP 0.047UF 16V X7R
C410	065G0402473 12	CHIP 0.047UF 16V X7R
C430	065G0402473 12	CHIP 0.047UF 16V X7R
C431	065G0402473 12	CHIP 0.047UF 16V X7R
FB406	071G 56Z601	CHIP BEAD 600 OHM 0805
FB407	071G 56Z601	CHIP BEAD 600 OHM 0805
FB408	071G 56Z601	CHIP BEAD 600 OHM 0805
FB409	071G 56Z601	CHIP BEAD 600 OHM 0805
FB404	071G 59B121	TB160808B
D412	093G 64 42 P	BAV70 SOT23 BY PAN JIT
D413	093G 64 42 P	BAV70 SOT23 BY PAN JIT
D411	093G 6433S	DIODE BAV99 SEMTECH

D410	093G 6433S	DIODE BAV99 SEMTECH
D409	093G 6433S	DIODE BAV99 SEMTECH
D408	093G 6433S	DIODE BAV99 SEMTECH
D407	093G 6433S	DIODE BAV99 SEMTECH
D406	093G 6433S	DIODE BAV99 SEMTECH
D405	093G 6433S	DIODE BAV99 SEMTECH
D404	093G 6433S	DIODE BAV99 SEMTECH
D403	093G 6433S	DIODE BAV99 SEMTECH
D402	093G 6433S	DIODE BAV99 SEMTECH
D401	093G 6433S	DIODE BAV99 SEMTECH
ZD401	093G 39P599 T	MM3Z5V6B
ZD402	093G 39P599 T	MM3Z5V6B
ZD403	093G 39P599 T	MM3Z5V6B
ZD404	093G 39P599 T	MM3Z5V6B
ZD405	093G 39P599 T	MM3Z5V6B
ZD406	093G 39P599 T	MM3Z5V6B
ZD407	093G 39P599 T	MM3Z5V6B
ZD408	093G 39P599 T	MM3Z5V6B
ZD409	093G 39P599 T	MM3Z5V6B
ZD410	093G 39P599 T	MM3Z5V6B
ZD411	093G 39P599 T	MM3Z5V6B
ZD413	093G 39P599 T	MM3Z5V6B
D414	093G 64S522SEM	LL4148
D701	093G1004 3	SS14
	715G2571 1 2	MAIN BOARD PCB
	KEPC7QAA5	KEY BAORD
CN101	033G8032 8D	WAFER 1.25MM
R108	061G0603000	RST CHIPR 0 OHM +-5% 1/10W
R105	061G0603000	RST CHIPR 0 OHM +-5% 1/10W
R102	061G0603000	RST CHIPR 0 OHM +-5% 1/10W
R103	061G0603103	RST CHIPR 10 KOHM +-5% 1/10W
R106	061G0603103	RST CHIPR 10 KOHM +-5% 1/10W
R101	061G0603393	RST CHIPR 39 KOHM +-5% 1/10W
R104	061G0603393	RST CHIPR 39 KOHM +-5% 1/10W
R107	061G0603393	RST CHIPR 39 KOHM +-5% 1/10W
C101	065G0603104 37	CHIP 0.1UF 50V/Y5V
C102	065G0603104 37	CHIP 0.1UF 50V/Y5V
C103	065G0603104 37	CHIP 0.1UF 50V/Y5V
C104	065G0603104 37	CHIP 0.1UF 50V/Y5V
C105	065G0603104 37	CHIP 0.1UF 50V/Y5V

SW101	077G 604 2 TO	TACT 5W BY TOUKE TS-9-TMG-553
SW102	077G 604 2 TO	TACT 5W BY TOUKE TS-9-TMG-553
SW103	077G 604 2 TO	TACT 5W BY TOUKE TS-9-TMG-553
SW104	077G 604 2 TO	TACT 5W BY TOUKE TS-9-TMG-553
SW105	077G 604 2 TO	TACT 5W BY TOUKE TS-9-TMG-553
LED101	081G 14 12 KT	CHIP LED
ZD102	093G 39P599 T	MM3Z5V6B
ZD101	093G 39P599 T	MM3Z5V6B
	715G2546 1	KEY BAORD PCB
	PWPC942HU3	POWER BOARD
CN801	033G8021 2E F	WAFER
CN802	033G8021 2E F	WAFER
CN803	033G8021 2E F	WAFER
CN804	033G8021 2E F	WAFER
	040G 45762420A	LABEL 25X6MM
	051G 6 4503	RTV
IC903	056G 139 3A	PC123Y22FZOF
NR901	061G 58080 WT	8 OHM NCT
R908	061G152M104 64	100KOHM 5% 2W
R914	061G152M228 64	0.22 OHM 5% 2W
C801	065G 3J1006ET	10PF,J,3KV,SL
C811	065G 3J1006ET	10PF,J,3KV,SL
C901	065G305M1022BP	Y2 1000PF M 250VAC Y5P
C902	065G305M1022BP	Y2 1000PF M 250VAC Y5P
C921	065G306M4722BP	4700PF +-20% 400VAC
C905	067G 40Z10115K	CAP 105°C 100UF M 450V
C803	067G215D4714KV	E.C 105°C CAP 470UF M 25V ED SERIES
C802	067G215D4714KV	E.C 105°C CAP 470UF M 25V ED SERIES
C918	067G215D6814KV	CAP 105°C 680UF M 25V
C917	067G215D6814KV	CAP 105°C 680UF M 25V
C939	067G215S1024KV	EC 105°C CAP 1000UF M 25V
C915	067G215S4713KV	EC 105°C CAP 470UF M 16V
L902	073G 174 65 H	LINE FILTER
L901	073G 174 76 H	FILTER
L903	073G 253191 H	IND CHOKE 1.1UH DADON
L904	073G 253191 YS	CHOKE COIL 1.1UH YS04110055
T901	080GL19T 23 YS	X'FMR 510UH YS04160061
T801	080GL19T 24 YS	X'FMR 1.12H YS04170127
T802	080GL19T 24 YS	X'FMR 1.12H YS04170127
CN901	087G 501 32 S	AC SOCKET

BD901	093G 50460 28	BRIDGE DIODE KBP208G LITEON
D907	093G3006 1 1	31DQ06FC3 NIHON INTER
CN902	095G8014 9D 58	HARNESS 9P-9P 210MM
	705G 193 57 01	Q901 ASS'Y
Q901	057G 667 21	STP10NK70ZFP
	090G6263 1	HEAT SINK
	AM1G1730 8120 GP	SCREW
	705G 193 93 01	D906 ASS'Y
D906	093G 60218	SB10100FCT
	AM1G1730 8120 GP	SCREW
	Q90G6274 2	HEAT SINK
IC801	056G 379 22	IC TL494IDR SOIC-16
IC901	056G 379 71	IC TEA1530AT SO-8 PHILIPS
Q811	057G 417 4	PMBS3904/PHILIPS-SMT(04)
Q807	057G 417 4	PMBS3904/PHILIPS-SMT(04)
Q806	057G 417 4	PMBS3904/PHILIPS-SMT(04)
Q801	057G 417 4	PMBS3904/PHILIPS-SMT(04)
Q812	057G 417 6	PMBS3906/PHILIPS-SMT(06)
Q804	057G 417 6	PMBS3906/PHILIPS-SMT(06)
Q809	057G 759 2	RK7002
Q810	057G 759 2	RK7002
Q808	057G 760 4B	PDTA144WK SOT346
Q805	057G 760 5B	PDTC144WK SOT346
Q802	057G 763 14	AM9945N
Q803	057G 763 14	AM9945N
R827	061G0603000	RST CHIPR 0 OHM +-5% 1/10W
R801	061G0603100 1F	RST CHIPR 1 KOHM +-1% 1/10W
R816	061G0603100 1F	RST CHIPR 1 KOHM +-1% 1/10W
R809	061G0603100 1F	RST CHIPR 1 KOHM +-1% 1/10W
R812	061G0603100 1F	RST CHIPR 1 KOHM +-1% 1/10W
R814	061G0603100 1F	RST CHIPR 1 KOHM +-1% 1/10W
R815	061G0603100 1F	RST CHIPR 1 KOHM +-1% 1/10W
R818	061G0603100 1F	RST CHIPR 1 KOHM +-1% 1/10W
R821	061G0603100 1F	RST CHIPR 1 KOHM +-1% 1/10W
R822	061G0603100 1F	RST CHIPR 1 KOHM +-1% 1/10W
R824	061G0603100 1F	RST CHIPR 1 KOHM +-1% 1/10W
R826	061G0603100 1F	RST CHIPR 1 KOHM +-1% 1/10W
R925	061G0603100 1F	RST CHIPR 1 KOHM +-1% 1/10W
R942	061G0603100 1F	RST CHIPR 1 KOHM +-1% 1/10W
R926	061G0603100 2F	RST CHIPR 10 KOHM +-1% 1/10W

R813	061G0603100 2F	RST CHIPR 10 KOHM +-1% 1/10W
R808	061G0603100 2F	RST CHIPR 10 KOHM +-1% 1/10W
R834	061G0603100 2F	RST CHIPR 10 KOHM +-1% 1/10W
R833	061G0603100 2F	RST CHIPR 10 KOHM +-1% 1/10W
R832	061G0603100 2F	RST CHIPR 10 KOHM +-1% 1/10W
R828	061G0603100 2F	RST CHIPR 10 KOHM +-1% 1/10W
R817	061G0603100 2F	RST CHIPR 10 KOHM +-1% 1/10W
R835	061G0603105	RST CHIPR 1 MOHM +-5% 1/10W
R862	061G0603105	RST CHIPR 1 MOHM +-5% 1/10W
R851	061G0603140 2F	RST CHIPR 14K OHM +-1% 1/10W
R924	061G0603152	RST CHIPR 1.5 KOHM +-5% 1/10W
R811	061G0603240 1F	RST CHIPR 2.4 KOHM +-1% 1/10W
R831	061G0603240 1F	RST CHIPR 2.4 KOHM +-1% 1/10W
R930	061G0603240 1F	RST CHIPR 2.4 KOHM +-1% 1/10W
R940	061G0603330 2F	RST CHIPR 33 KOHM +-1% 1/10W
R927	061G0603360 1F	RST CHIPR 3.6 KOHM +-1% 1/10W
R823	061G0603362	RST CHIPR 3.6 KOHM +-5% 1/10W
R819	061G0603362	RST CHIPR 3.6 KOHM +-5% 1/10W
R861	061G0603390 3F	RST CHIPR 390 KOHM +-1% 1/10W
R820	061G0603470 2F	RST CHIPR 47 KOHM +-1% 1/10W
R803	061G0603564	RST CHIPR 560 KOHM +-5% 1/10W
R807	061G0603680 2F	RST CHIPR 68 KOHM +-1% 1/10W
R854	061G0603680 2F	RST CHIPR 68 KOHM +-1% 1/10W
R853	061G0603680 2F	RST CHIPR 68 KOHM +-1% 1/10W
R841	061G0603680 2F	RST CHIPR 68 KOHM +-1% 1/10W
R806	061G0603680 2F	RST CHIPR 68 KOHM +-1% 1/10W
R850	061G0805000	0 OHM 1/10W
R839	061G0805000	0 OHM 1/10W
R804	061G0805101	RST CHIPR 100 OHM +-5% 1/8W
R917	061G0805102	RST CHIPR 1KOHM +-5% 1/8W
R911	061G0805102	RST CHIPR 1KOHM +-5% 1/8W
R938	061G0805103	10 KOHM 1/10W
R916	061G0805152	RST CHIPR 1.5 KOHM +-5% 1/8W
R829	061G0805220	22&8 1/10W
R825	061G0805220	22&8 1/10W
R912	061G0805220 2F	RST CHIPR 22 KOHM +-1% 1/8W
R915	061G0805224	RST CHIPR 220 KOHM +-5% 1/8W
R837	061G0805473	RST CHIPR 47 KOHM +-5% 1/8W
R810	061G0805510 2F	RST CHIPR 51 KOHM +-1% 1/8W
R931	061G0805822	RST CHIPR 8.2 KOHM +-5% 1/8W

F801	061G1206000	RST CHIPR 0 OHM +-5% 1/4W
F902	061G1206000	RST CHIPR 0 OHM +-5% 1/4W
JR802	061G1206000	RST CHIPR 0 OHM +-5% 1/4W
JR803	061G1206000	RST CHIPR 0 OHM +-5% 1/4W
JR801	061G1206000	RST CHIPR 0 OHM +-5% 1/4W
R967	061G1206000	RST CHIPR 0 OHM +-5% 1/4W
JR901	061G1206000	RST CHIPR 0 OHM +-5% 1/4W
JR809	061G1206000	RST CHIPR 0 OHM +-5% 1/4W
JR808	061G1206000	RST CHIPR 0 OHM +-5% 1/4W
JR807	061G1206000	RST CHIPR 0 OHM +-5% 1/4W
JR805	061G1206000	RST CHIPR 0 OHM +-5% 1/4W
JR804	061G1206000	RST CHIPR 0 OHM +-5% 1/4W
R910	061G1206100	RST CHIP 10R 1/4W 5%
R909	061G1206100	RST CHIP 10R 1/4W 5%
R918	061G1206101	100 1206
R919	061G1206101	100 1206
R920	061G1206101	100 1206
R935	061G1206101	100 1206
R961	061G1206101	100 1206
R962	061G1206101	100 1206
R855	061G1206330	RST CHIPR 33 OHM +-5% 1/4W
R857	061G1206330	RST CHIPR 33 OHM +-5% 1/4W
R904	061G1206472	RST CHIPR 4.7 KOHM +-5% 1/4W
R932	061G1206472	RST CHIPR 4.7 KOHM +-5% 1/4W
R933	061G1206472	RST CHIPR 4.7 KOHM +-5% 1/4W
R901	061G1206684	RST CHIPR 680 KOHM +-5% 1/4W
R902	061G1206684	RST CHIPR 680 KOHM +-5% 1/4W
R903	061G1206684	RST CHIPR 680 KOHM +-5% 1/4W
C842	065G0603103 12	CHIP 0.01UF 16V X7R
C924	065G0603103 12	CHIP 0.01UF 16V X7R
C807	065G0603104 22	CHIP 0.1UF 25V X7R
C821	065G0603104 22	CHIP 0.1UF 25V X7R
C825	065G0603104 22	CHIP 0.1UF 25V X7R
C834	065G0603104 22	CHIP 0.1UF 25V X7R
C815	065G0603222 22	CHIP 2200PF 25V X7R
C816	065G0603222 22	CHIP 2200PF 25V X7R
C819	065G0603222 22	CHIP 2200PF 25V X7R
C823	065G0603222 22	CHIP 2200PF 25V X7R
C839	065G0805102 31	1000PF 50V NPO
C840	065G0805102 31	1000PF 50V NPO

C805	065G0805104 32	CHIP 0.1U 50V X7R
C824	065G0805104 32	CHIP 0.1U 50V X7R
C907	065G0805104 32	CHIP 0.1U 50V X7R
C916	065G0805104 32	CHIP 0.1U 50V X7R
C930	065G0805104 32	CHIP 0.1U 50V X7R
C931	065G0805104 32	CHIP 0.1U 50V X7R
C822	065G0805105 22	CHIP 1UF 25V X7R 0805
C928	065G0805122 31	CHIP CAP 0805 1200PF J 50V NPO
C820	065G080522131G	220PF 50V NPO 2%
C911	065G0805224 22	CAIP CAP 0.22 UF 25V X7R
C909	065G0805224 32	0.22UF,K,50V,X7R
C845	065G0805225 12	CHIP 2.2UF 16V X7R 0805
C929	065G1206102 72	CHIP 1000PF 500V X7R
C912	065G1206102 72	CHIP 1000PF 500V X7R
D805	093G 64 38 D	DIODE BAW56 DIODES
D808	093G 64 38 D	DIODE BAW56 DIODES
D809	093G 64 44 S	LL4148WP
D916	093G 64 44 S	LL4148WP
D915	093G 64 44 S	LL4148WP
D903	093G 64 44 S	LL4148WP
D817	093G 64 44 S	LL4148WP
D814	093G 64 44 S	LL4148WP
D806	093G 64 44 S	LL4148WP
D801	093G 6433P	BAV99
D802	093G 6433P	BAV99
D803	093G 6433P	BAV99
D804	093G 6433P	BAV99
ZD921	093G 39S 15 T	RLZ15B LLDS
ZD922	093G 39S 25 T	RLZ5.1B LLDS
CN901	006G 31500	EYELET
IC904	056G 158 12	KIA431A-AT/P TO-92
C938	065G 2K152 1T6052	1.5NF/2KV Y5P +-10%
C906	065G 2K152 1T6052	1.5NF/2KV Y5P +-10%
C908	067G215Y2207KT	CAP 105°C 22UF M 50V KINGNICH
FB901	071G 55 29	FERRITE BEAD
F901	084G 55 1W	FUSE 4A 250V WICKMANN
D901	093G 6038P52T	PS102R
D900	093G1100 1052T	BA159GPT DO-41 CHENMKO
	715G2538 1	POWER BOARD PCB
	Q07G 7 T164	COMPOUND PALLET

	Q40G 19N68013A	RATING LABEL
	Q40G000268013A	TRY ME LABEL
	Q40G000268014A	TCO' 03 LABEL
	Q40G000268018A	SPLENDID LABEL
	Q41G780068025B	EU WARRANTY CARD NON ZBD
	Q44G6002CP212A	PAPER CAP
	Q44G9063 1	EPS(L)
	Q44G9063 2	EPS(R)
	Q44G9063680 1A	19 LCD ASUS CARTON
	Q45G 76 28V13 R	PE BAG
	Q45G 88607 25	PE BAG FOR BASE
	Q45G 88609 87	EPE COVER FOR MONITOR
	Q52G 1185 69	ASUS BIG TAPE
	Q52G6019 24	TAPE-FIX FOR ASUS
	040G 58162435A	LABEL
	070GHDCP500MST	MSTAR HDCP
	Q41G780068034A	QSG VB171D/VB191D
	Q45G 76 28 RN R	PE BAG MANUAL
	Q70G1700680 3A	CD MANUAL

For VB191S

T97HMWDKHGUSA

Location	Part No.	Description
	040G 457834 4A GP	S/N LABEL FOR ID
	040G 457842 2B	PALLET LABEL
	040G 581680 1A	WARRANTY LABEL
	040G 582680 3A	PALLET LABEL
	040G 582680 4A	CARTON LABEL
	044G9003202	CORNER PAPER
	044GH600 1	HANDLE2
	050G 600 4	HANDLE 1
	052G 1186	SMALL TAPE
	052G 1211 A	165MINIUM TAPE
	052G6020 5	PROTECT FILM
E089C	089G 17356T554	AUDIO CABLE
E089	089G 728GAA D1	SIGNAL CABLE
E089B	089G402A18N IS	POWER CORD
	095G801412D 80	HARNESS 8P-12P 360MM
	095G801830D154	HARNESS 30P-24P 200MM
	0M1G 130 5120	SCREW
	0M1G 930 5 47 CR3	SCREW
	0M1G1730 6120	SCREW
	0M1G1730 6120	SCREW
	0M1G1730 6120	SCREW
	705GQ734090	STAND ASS'Y(19")
	0Q1G1740 10120	SCREW
	A34G0326ADJ 1B	STAND
	A37G0037 2	HINGE
	705GQ734093	MAIN FRAME ASS'Y(19")
	078G 322 9 G	SPEAKER 8 OHM 1.5W L:230 MM 43X18MM
	0M1G1840 8120	SCREW
	A15G0215 2	MAINFRAME
E750L	750GLH90N3A11N	PANEL HSD190MEN3-A 19" HANNSTAR
	A33G0188ADJ 1L	BUTTON FUNC
	A33G0189 1 1C	LENS POWER
	A34G0323ADJ 1B 33	BASE
	A34G0324ADJA1B 30	BEZEL L19A-7ASUS
	A34G0325ADJ 3B 30	REAR COVER(19)
	A34G0327ADJ 1B	STAND_COVER
	AM1G1740 10120	SCREW(M4*8)

	AUPC7QU1	AUDIO G2098-1-X-X-4-070117
CN203	033G3802 4	WAFER EH-4
CN202	033G802410C H	CONNECTOR
U201	056G 616 1	IC E-TDA7496L ST
C205	067G215B471 3N GP	KY16VB470M-L 8*15MM
C207	067G215B471 3N GP	KY16VB470M-L 8*15MM
C208	067G215V471 3N GP	KY16VB470M-CC3 10*12.5
C202	067G215V471 4N GP	KY25VB470M-CC3 10*16
C201	067G215V471 4N GP	KY25VB470M-CC3 10*16
CN201	088G 30210K E	PHONE JACK 5PIN
	090G6093 1	HEAT SINK
R208	061G0603102	RST CHIP 1K 1/10W 5%
R207	061G0603102	RST CHIP 1K 1/10W 5%
R203	061G0603183	RST CHIPR 18 KOHM +-5% 1/10W
R201	061G0603183	RST CHIPR 18 KOHM +-5% 1/10W
R211	061G0603203	RST CHIPR 20 KOHM +-5% 1/10W
R210	061G0603203	RST CHIPR 20 KOHM +-5% 1/10W
R202	061G0603204	RST CHIPR 200 KOHM +-5% 1/10W
R212	061G0603224	RST CHIPR 220 KOHM +-5% 1/10W
C211	065G0603101 31	CER1 0603 NP0 50V 100P PM5 R
C212	065G0603101 31	CER1 0603 NP0 50V 100P PM5 R
C213	065G0603104 32	CHIP 0.1UF 50V X7R
C203	065G0603104 32	CHIP 0.1UF 50V X7R
C206	065G0603474 27	CHIP 0.47UF 25V Y5V
C204	065G0603474 27	CHIP 0.47UF 25V Y5V
C209	067G 2151097NT	KMY50VB1M-TP5 5*11.5
C210	067G 2151097NT	KMY50VB1M-TP5 5*11.5
	715G2098 1ASU	AUDIO-BOARD PCB
	CBPC7HMWJSQ1	MAIN BOARD
CN701	033G3802 9	WAFER 9P RIGHT ANELE PITCH
CN403	033G801710A BH	CONNECTOR
CN404	033G8027 12	WAFER 2*6P 2.0MM R/A
CN703	033G8027 24 H	CONN W TO B12P*2 P*2.0 4505-2
	040G 457624 1B	LABEL-CPU
	040G 45762412B	CBPC LABEL
C702	067G215V101 4N	KY25VB100M-CC3(6.3*11)
C701	067G215V101 7P	CAP L105°C 100UF M 50V JIANGHAI
C426	067G215Y100 7N	KY50VB10M-L 5*11
C441	067G215Y100 7N	KY50VB10M-L 5*11
C706	067G215Y100 7N	KY50VB10M-L 5*11

C711	067G215Y100 7N	KY50VB10M-L 5*11
C708	067G215Y100 7N	KY50VB10M-L 5*11
C712	067G215Y2207NV	KY50VB22M-CC3 5*11
CN401	088G 35315F H	D-SUB 15PIN
X401	093G 2253B J	14.31818MHZ/85C
U401	056G 562138	IC TSUM16AWK-LF PQFP-128 MST
U702	056G 563 27	IC AIC1117A-18PYTR-R SOT223
U701	056G 585 4	IC AIC1117-33PYTR-R AIC
U403	056G1133 34	M24C02-WMN6TP
U406	056G1133 56	M24C16-WMN6TP
U402	056G1133713	IC PM25LV010A-100SCE SOIC-8
Q402	057G 417 4	PMBS3904/PHILIPS-SMT(04)
Q405	057G 417 4	PMBS3904/PHILIPS-SMT(04)
Q701	057G 417 4	PMBS3904/PHILIPS-SMT(04)
Q702	057G 417 4	PMBS3904/PHILIPS-SMT(04)
Q403	057G 417 6	PMBS3906/PHILIPS-SMT(06)
Q404	057G 417 6	PMBS3906/PHILIPS-SMT(06)
Q704	057G 417 6	PMBS3906/PHILIPS-SMT(06)
Q411	057G 417 12 T	KEC 2N3904S-RTK/PS
Q412	057G 417 12 T	KEC 2N3904S-RTK/PS
Q408	057G 758 1	2N7002ESOT23 SILICONIX
Q409	057G 758 1	2N7002ESOT23 SILICONIX
Q703	057G 763 1	A03401 SOT23 BY AOS(A1)
R405	061G0402101	RST CHIPR 100 OHM +-5% 1/16W
R407	061G0402101	RST CHIPR 100 OHM +-5% 1/16W
R409	061G0402101	RST CHIPR 100 OHM +-5% 1/16W
R460	061G0402101	RST CHIPR 100 OHM +-5% 1/16W
R461	061G0402101	RST CHIPR 100 OHM +-5% 1/16W
R462	061G0402101	RST CHIPR 100 OHM +-5% 1/16W
R472	061G0402101	RST CHIPR 100 OHM +-5% 1/16W
R474	061G0402101	RST CHIPR 100 OHM +-5% 1/16W
R476	061G0402101	RST CHIPR 100 OHM +-5% 1/16W
R414	061G0402102	RST CHIPR 1 KOHM +-5% 1/16W
R416	061G0402102	RST CHIPR 1 KOHM +-5% 1/16W
R485	061G0402102	RST CHIPR 1 KOHM +-5% 1/16W
R516	061G0402102	RST CHIPR 1 KOHM +-5% 1/16W
R518	061G0402102	RST CHIPR 1 KOHM +-5% 1/16W
R412	061G0402102	RST CHIPR 1 KOHM +-5% 1/16W
R720	061G0402102	RST CHIPR 1 KOHM +-5% 1/16W
R465	061G0402102	RST CHIPR 1 KOHM +-5% 1/16W

R469	061G0402102	RST CHIPR 1 KOHM +-5% 1/16W
R718	061G0402103	RST CHIPR 10 KOHM +-5% 1/16W
R421	061G0402103	RST CHIPR 10 KOHM +-5% 1/16W
R444	061G0402103	RST CHIPR 10 KOHM +-5% 1/16W
R445	061G0402103	RST CHIPR 10 KOHM +-5% 1/16W
R449	061G0402103	RST CHIPR 10 KOHM +-5% 1/16W
R451	061G0402103	RST CHIPR 10 KOHM +-5% 1/16W
R457	061G0402103	RST CHIPR 10 KOHM +-5% 1/16W
R458	061G0402103	RST CHIPR 10 KOHM +-5% 1/16W
R473	061G0402103	RST CHIPR 10 KOHM +-5% 1/16W
R475	061G0402103	RST CHIPR 10 KOHM +-5% 1/16W
R477	061G0402103	RST CHIPR 10 KOHM +-5% 1/16W
R486	061G0402103	RST CHIPR 10 KOHM +-5% 1/16W
R704	061G0402103	RST CHIPR 10 KOHM +-5% 1/16W
R708	061G0402103	RST CHIPR 10 KOHM +-5% 1/16W
R710	061G0402103	RST CHIPR 10 KOHM +-5% 1/16W
R411	061G0402103	RST CHIPR 10 KOHM +-5% 1/16W
R479	061G0402103	RST CHIPR 10 KOHM +-5% 1/16W
R482	061G0402103	RST CHIPR 10 KOHM +-5% 1/16W
R459	061G0402203	RST CHIP 20K 1/16W 5%
R480	061G0402203	RST CHIP 20K 1/16W 5%
R481	061G0402203	RST CHIP 20K 1/16W 5%
R446	061G0402220	RST CHIPR 22 OHM +-5% 1/16W
R447	061G0402220	RST CHIPR 22 OHM +-5% 1/16W
R413	061G0402222	RST CHIPR 2.2 KOHM +-5% 1/16W
R415	061G0402222	RST CHIPR 2.2 KOHM +-5% 1/16W
R456	061G0402223	RST CHIPR 22 KOHM +-5% 1/16W
R466	061G0402241	RST CHIP 240R 1/16W 5%
R470	061G0402241	RST CHIP 240R 1/16W 5%
R442	061G0402390 0F	RST CHIP 390R 1/16W 1%
R483	061G0402392	RST CHIP 3.9K 1/16W 5%
R478	061G0402392	RST CHIP 3.9K 1/16W 5%
R702	061G0402470	RST CHIPR 47 OHM +-5% 1/16W
R506	061G0402470	RST CHIPR 47 OHM +-5% 1/16W
R503	061G0402470	RST CHIPR 47 OHM +-5% 1/16W
R502	061G0402470	RST CHIPR 47 OHM +-5% 1/16W
R499	061G0402470	RST CHIPR 47 OHM +-5% 1/16W
R410	061G0402471	RST CHIPR 470 OHM +-5% 1/16W
R464	061G0402472	RST CHIPR 4.7 KOHM +-5% 1/16W
R468	061G0402472	RST CHIPR 4.7 KOHM +-5% 1/16W

R484	061G0402472	RST CHIPR 4.7 KOHM +-5% 1/16W
R500	061G0402472	RST CHIPR 4.7 KOHM +-5% 1/16W
R504	061G0402472	RST CHIPR 4.7 KOHM +-5% 1/16W
R703	061G0402472	RST CHIPR 4.7 KOHM +-5% 1/16W
R705	061G0402472	RST CHIPR 4.7 KOHM +-5% 1/16W
R709	061G0402472	RST CHIPR 4.7 KOHM +-5% 1/16W
R418	061G0402472	RST CHIPR 4.7 KOHM +-5% 1/16W
R420	061G0402472	RST CHIPR 4.7 KOHM +-5% 1/16W
R417	061G0402510 Y	RST CHIP 51R 1/16W 5%
R419	061G0402510 Y	RST CHIP 51R 1/16W 5%
R711	061G0402513	RST CHIP 51K 1/16W 5%
R404	061G0402560 9F	RST CHIPR 56 OHM +-1% 1/16W
R406	061G0402560 9F	RST CHIPR 56 OHM +-1% 1/16W
R408	061G0402560 9F	RST CHIPR 56 OHM +-1% 1/16W
R467	061G0402681	RST CHIPR 680 OHM +-5% 1/16W
R471	061G0402681	RST CHIPR 680 OHM +-5% 1/16W
R401	061G0402750 9F	RST CHIP 75 OHM 1/16W 1%
R402	061G0402750 9F	RST CHIP 75 OHM 1/16W 1%
R403	061G0402750 9F	RST CHIP 75 OHM 1/16W 1%
FB401	061G0603000	RST CHIPR 0 OHM +-5% 1/10W
FB402	061G0603000	RST CHIPR 0 OHM +-5% 1/10W
FB403	061G0603000	RST CHIPR 0 OHM +-5% 1/10W
R712	061G0603103	RST CHIPR 10 KOHM +-5% 1/10W
FB405	061G0805000	0 OHM 1/10W
R713	061G1206301	RST CHIPR 300 OHM +-5% 1/4W
R714	061G1206301	RST CHIPR 300 OHM +-5% 1/4W
C451	065G0402102 32	1000PF +-10% 50V X7R
C452	065G0402102 32	1000PF +-10% 50V X7R
C453	065G0402102 32	1000PF +-10% 50V X7R
C440	065G0402104 15	MLCC 0402 0.1UF K 16V X5R
C446	065G0402104 15	MLCC 0402 0.1UF K 16V X5R
C447	065G0402104 15	MLCC 0402 0.1UF K 16V X5R
C704	065G0402104 15	MLCC 0402 0.1UF K 16V X5R
C705	065G0402104 15	MLCC 0402 0.1UF K 16V X5R
C707	065G0402104 15	MLCC 0402 0.1UF K 16V X5R
C709	065G0402104 15	MLCC 0402 0.1UF K 16V X5R
C710	065G0402104 15	MLCC 0402 0.1UF K 16V X5R
C439	065G0402104 15	MLCC 0402 0.1UF K 16V X5R
C438	065G0402104 15	MLCC 0402 0.1UF K 16V X5R
C437	065G0402104 15	MLCC 0402 0.1UF K 16V X5R

C436	065G0402104 15	MLCC 0402 0.1UF K 16V X5R
C424	065G0402104 15	MLCC 0402 0.1UF K 16V X5R
C403	065G0402104 15	MLCC 0402 0.1UF K 16V X5R
C402	065G0402104 15	MLCC 0402 0.1UF K 16V X5R
C401	065G0402104 15	MLCC 0402 0.1UF K 16V X5R
C450	065G0402105 A5	CAP 0402 1UF K 10V X5R
C428	065G0402220 31	CHIP 22PF 50V NPO
C429	065G0402220 31	CHIP 22PF 50V NPO
C434	065G0402221 32	MLCC 0402 CAP 220PF J 50V X7R
C433	065G0402221 32	MLCC 0402 CAP 220PF J 50V X7R
C412	065G0402221 32	MLCC 0402 CAP 220PF J 50V X7R
C448	065G0402224 17	CAP CER 0.22UF -20%-80%
C413	065G0402224 17	CAP CER 0.22UF -20%-80%
C425	065G0402224 17	CAP CER 0.22UF -20%-80%
C411	065G0402330 31	33PF +-50% 50V NPO
C432	065G0402330 31	33PF +-50% 50V NPO
C404	065G0402473 12	CHIP 0.047UF 16V X7R
C405	065G0402473 12	CHIP 0.047UF 16V X7R
C445	065G0402473 12	CHIP 0.047UF 16V X7R
C444	065G0402473 12	CHIP 0.047UF 16V X7R
C443	065G0402473 12	CHIP 0.047UF 16V X7R
C442	065G0402473 12	CHIP 0.047UF 16V X7R
C435	065G0402473 12	CHIP 0.047UF 16V X7R
C431	065G0402473 12	CHIP 0.047UF 16V X7R
C430	065G0402473 12	CHIP 0.047UF 16V X7R
C410	065G0402473 12	CHIP 0.047UF 16V X7R
C409	065G0402473 12	CHIP 0.047UF 16V X7R
C408	065G0402473 12	CHIP 0.047UF 16V X7R
C407	065G0402473 12	CHIP 0.047UF 16V X7R
C406	065G0402473 12	CHIP 0.047UF 16V X7R
FB409	071G 56Z601	CHIP BEAD 600 OHM 0805
FB408	071G 56Z601	CHIP BEAD 600 OHM 0805
FB407	071G 56Z601	CHIP BEAD 600 OHM 0805
FB406	071G 56Z601	CHIP BEAD 600 OHM 0805
FB404	071G 59B121	TB160808B
D412	093G 64 42 P	BAV70 SOT23 BY PAN JIT
D401	093G 6433S	DIODE BAV99 SEMTECH
D402	093G 6433S	DIODE BAV99 SEMTECH
D403	093G 6433S	DIODE BAV99 SEMTECH
ZD413	093G 39P599 T	MM3Z5V6B

ZD406	093G 39P599 T	MM3Z5V6B
ZD405	093G 39P599 T	MM3Z5V6B
ZD404	093G 39P599 T	MM3Z5V6B
ZD403	093G 39P599 T	MM3Z5V6B
ZD402	093G 39P599 T	MM3Z5V6B
ZD401	093G 39P599 T	MM3Z5V6B
D414	093G 64S522SEM	LL4148
D701	093G1004 3	SS14
	715G2571 1 2	MAIN BOARD PCB
	KEPC7QAA5	KEY BAORD
CN101	033G8032 8D	WAFER 1.25MM
R108	061G0603000	RST CHIPR 0 OHM +-5% 1/10W
R105	061G0603000	RST CHIPR 0 OHM +-5% 1/10W
R102	061G0603000	RST CHIPR 0 OHM +-5% 1/10W
R103	061G0603103	RST CHIPR 10 KOHM +-5% 1/10W
R106	061G0603103	RST CHIPR 10 KOHM +-5% 1/10W
R101	061G0603393	RST CHIPR 39 KOHM +-5% 1/10W
R104	061G0603393	RST CHIPR 39 KOHM +-5% 1/10W
R107	061G0603393	RST CHIPR 39 KOHM +-5% 1/10W
C101	065G0603104 37	CHIP 0.1UF 50V/Y5V
C102	065G0603104 37	CHIP 0.1UF 50V/Y5V
C103	065G0603104 37	CHIP 0.1UF 50V/Y5V
C104	065G0603104 37	CHIP 0.1UF 50V/Y5V
C105	065G0603104 37	CHIP 0.1UF 50V/Y5V
SW101	077G 604 2 TO	TACT 5W BY TOUKE TS-9-TMG-553
SW102	077G 604 2 TO	TACT 5W BY TOUKE TS-9-TMG-553
SW103	077G 604 2 TO	TACT 5W BY TOUKE TS-9-TMG-553
SW104	077G 604 2 TO	TACT 5W BY TOUKE TS-9-TMG-553
SW105	077G 604 2 TO	TACT 5W BY TOUKE TS-9-TMG-553
LED101	081G 14 12 KT	CHIP LED
ZD102	093G 39P599 T	MM3Z5V6B
ZD101	093G 39P599 T	MM3Z5V6B
	715G2546 1	KEY BAORD PCB
	PWPC942HU3	POWER BOARD
CN801	033G8021 2E F	WAFER
CN802	033G8021 2E F	WAFER
CN803	033G8021 2E F	WAFER
CN804	033G8021 2E F	WAFER
	040G 45762420A	LABEL 25X6MM
	051G 6 4503	RTV

IC903	056G 139 3A	PC123Y22FZOF
NR901	061G 58080 WT	8 OHM NCT
R908	061G152M104 64	100KOHM 5% 2W
R914	061G152M228 64	0.22 OHM 5% 2W
C801	065G 3J1006ET	10PF,J,3KV,SL
C811	065G 3J1006ET	10PF,J,3KV,SL
C901	065G305M1022BP	Y2 1000PF M 250VAC Y5P
C902	065G305M1022BP	Y2 1000PF M 250VAC Y5P
C921	065G306M4722BP	4700PF +-20% 400VAC
C905	067G 40Z10115K	CAP 105°C 100UF M 450V
C803	067G215D4714KV	E.C 105°C CAP 470UF M 25V ED SERIES
C802	067G215D4714KV	E.C 105°C CAP 470UF M 25V ED SERIES
C918	067G215D6814KV	CAP 105°C 680UF M 25V
C917	067G215D6814KV	CAP 105°C 680UF M 25V
C939	067G215S1024KV	EC 105°C CAP 1000UF M 25V
C915	067G215S4713KV	EC 105°C CAP 470UF M 16V
L902	073G 174 65 H	LINE FILTER
L901	073G 174 76 H	FILTER
L903	073G 253191 H	IND CHOKE 1.1UH DADON
L904	073G 253191 YS	CHOKE COIL 1.1UH YS04110055
T901	080GL19T 23 YS	X'FMR 510UH YS04160061
T801	080GL19T 24 YS	X'FMR 1.12H YS04170127
T802	080GL19T 24 YS	X'FMR 1.12H YS04170127
CN901	087G 501 32 S	AC SOCKET
BD901	093G 50460 28	BRIDGE DIODE KBP208G LITEON
D907	093G3006 1 1	31DQ06FC3 NIHON INTER
CN902	095G8014 9D 58	HARNESS 9P-9P 210MM
	705G 193 57 01	Q901 ASS'Y
Q901	057G 667 21	STP10NK70ZFP
	Q90G6263 1	HEAT SINK
	AM1G1730 8120 GP	SCREW
	705G 193 93 01	D906 ASS'Y
D906	093G 60218	SB10100FCT
	AM1G1730 8120 GP	SCREW
	Q90G6274 2	HEAT SINK
IC801	056G 379 22	IC TL494IDR SOIC-16
IC901	056G 379 71	IC TEA1530AT SO-8 PHILIPS
Q811	057G 417 4	PMBS3904/PHILIPS-SMT(04)
Q807	057G 417 4	PMBS3904/PHILIPS-SMT(04)
Q806	057G 417 4	PMBS3904/PHILIPS-SMT(04)

Q801	057G 417 4	PMBS3904/PHILIPS-SMT(04)
Q812	057G 417 6	PMBS3906/PHILIPS-SMT(06)
Q804	057G 417 6	PMBS3906/PHILIPS-SMT(06)
Q809	057G 759 2	RK7002
Q810	057G 759 2	RK7002
Q808	057G 760 4B	PDTA144WK SOT346
Q805	057G 760 5B	PDTC144WK SOT346
Q802	057G 763 14	AM9945N
Q803	057G 763 14	AM9945N
R827	061G0603000	RST CHIPR 0 OHM +-5% 1/10W
R801	061G0603100 1F	RST CHIPR 1 KOHM +-1% 1/10W
R816	061G0603100 1F	RST CHIPR 1 KOHM +-1% 1/10W
R809	061G0603100 1F	RST CHIPR 1 KOHM +-1% 1/10W
R812	061G0603100 1F	RST CHIPR 1 KOHM +-1% 1/10W
R814	061G0603100 1F	RST CHIPR 1 KOHM +-1% 1/10W
R815	061G0603100 1F	RST CHIPR 1 KOHM +-1% 1/10W
R818	061G0603100 1F	RST CHIPR 1 KOHM +-1% 1/10W
R821	061G0603100 1F	RST CHIPR 1 KOHM +-1% 1/10W
R822	061G0603100 1F	RST CHIPR 1 KOHM +-1% 1/10W
R824	061G0603100 1F	RST CHIPR 1 KOHM +-1% 1/10W
R826	061G0603100 1F	RST CHIPR 1 KOHM +-1% 1/10W
R925	061G0603100 1F	RST CHIPR 1 KOHM +-1% 1/10W
R942	061G0603100 1F	RST CHIPR 1 KOHM +-1% 1/10W
R926	061G0603100 2F	RST CHIPR 10 KOHM +-1% 1/10W
R813	061G0603100 2F	RST CHIPR 10 KOHM +-1% 1/10W
R808	061G0603100 2F	RST CHIPR 10 KOHM +-1% 1/10W
R834	061G0603100 2F	RST CHIPR 10 KOHM +-1% 1/10W
R833	061G0603100 2F	RST CHIPR 10 KOHM +-1% 1/10W
R832	061G0603100 2F	RST CHIPR 10 KOHM +-1% 1/10W
R828	061G0603100 2F	RST CHIPR 10 KOHM +-1% 1/10W
R817	061G0603100 2F	RST CHIPR 10 KOHM +-1% 1/10W
R835	061G0603105	RST CHIPR 1 MOHM +-5% 1/10W
R862	061G0603105	RST CHIPR 1 MOHM +-5% 1/10W
R851	061G0603140 2F	RST CHIPR 14K OHM +-1% 1/10W
R924	061G0603152	RST CHIPR 1.5 KOHM +-5% 1/10W
R811	061G0603240 1F	RST CHIPR 2.4 KOHM +-1% 1/10W
R831	061G0603240 1F	RST CHIPR 2.4 KOHM +-1% 1/10W
R930	061G0603240 1F	RST CHIPR 2.4 KOHM +-1% 1/10W
R940	061G0603330 2F	RST CHIPR 33 KOHM +-1% 1/10W
R927	061G0603360 1F	RST CHIPR 3.6 KOHM +-1% 1/10W

R823	061G0603362	RST CHIPR 3.6 KOHM +-5% 1/10W
R819	061G0603362	RST CHIPR 3.6 KOHM +-5% 1/10W
R861	061G0603390 3F	RST CHIPR 390 KOHM +-1% 1/10W
R820	061G0603470 2F	RST CHIPR 47 KOHM +-1% 1/10W
R803	061G0603564	RST CHIPR 560 KOHM +-5% 1/10W
R807	061G0603680 2F	RST CHIPR 68 KOHM +-1% 1/10W
R854	061G0603680 2F	RST CHIPR 68 KOHM +-1% 1/10W
R853	061G0603680 2F	RST CHIPR 68 KOHM +-1% 1/10W
R841	061G0603680 2F	RST CHIPR 68 KOHM +-1% 1/10W
R806	061G0603680 2F	RST CHIPR 68 KOHM +-1% 1/10W
R850	061G0805000	0 OHM 1/10W
R839	061G0805000	0 OHM 1/10W
R804	061G0805101	RST CHIPR 100 OHM +-5% 1/8W
R917	061G0805102	RST CHIPR 1KOHM +-5% 1/8W
R911	061G0805102	RST CHIPR 1KOHM +-5% 1/8W
R938	061G0805103	10 KOHM 1/10W
R916	061G0805152	RST CHIPR 1.5 KOHM +-5% 1/8W
R829	061G0805220	22&8 1/10W
R825	061G0805220	22&8 1/10W
R912	061G0805220 2F	RST CHIPR 22 KOHM +-1% 1/8W
R915	061G0805224	RST CHIPR 220 KOHM +-5% 1/8W
R837	061G0805473	RST CHIPR 47 KOHM +-5% 1/8W
R810	061G0805510 2F	RST CHIPR 51 KOHM +-1% 1/8W
R931	061G0805822	RST CHIPR 8.2 KOHM +-5% 1/8W
F801	061G1206000	RST CHIPR 0 OHM +-5% 1/4W
F902	061G1206000	RST CHIPR 0 OHM +-5% 1/4W
JR802	061G1206000	RST CHIPR 0 OHM +-5% 1/4W
JR803	061G1206000	RST CHIPR 0 OHM +-5% 1/4W
JR801	061G1206000	RST CHIPR 0 OHM +-5% 1/4W
R967	061G1206000	RST CHIPR 0 OHM +-5% 1/4W
JR901	061G1206000	RST CHIPR 0 OHM +-5% 1/4W
JR809	061G1206000	RST CHIPR 0 OHM +-5% 1/4W
JR808	061G1206000	RST CHIPR 0 OHM +-5% 1/4W
JR807	061G1206000	RST CHIPR 0 OHM +-5% 1/4W
JR805	061G1206000	RST CHIPR 0 OHM +-5% 1/4W
JR804	061G1206000	RST CHIPR 0 OHM +-5% 1/4W
R910	061G1206100	RST CHIP 10R 1/4W 5%
R909	061G1206100	RST CHIP 10R 1/4W 5%
R918	061G1206101	100 1206
R919	061G1206101	100 1206

R920	061G1206101	100 1206
R935	061G1206101	100 1206
R961	061G1206101	100 1206
R962	061G1206101	100 1206
R855	061G1206330	RST CHIPR 33 OHM +-5% 1/4W
R857	061G1206330	RST CHIPR 33 OHM +-5% 1/4W
R904	061G1206472	RST CHIPR 4.7 KOHM +-5% 1/4W
R932	061G1206472	RST CHIPR 4.7 KOHM +-5% 1/4W
R933	061G1206472	RST CHIPR 4.7 KOHM +-5% 1/4W
R901	061G1206684	RST CHIPR 680 KOHM +-5% 1/4W
R902	061G1206684	RST CHIPR 680 KOHM +-5% 1/4W
R903	061G1206684	RST CHIPR 680 KOHM +-5% 1/4W
C842	065G0603103 12	CHIP 0.01UF 16V X7R
C924	065G0603103 12	CHIP 0.01UF 16V X7R
C807	065G0603104 22	CHIP 0.1UF 25V X7R
C821	065G0603104 22	CHIP 0.1UF 25V X7R
C825	065G0603104 22	CHIP 0.1UF 25V X7R
C834	065G0603104 22	CHIP 0.1UF 25V X7R
C815	065G0603222 22	CHIP 2200PF 25V X7R
C816	065G0603222 22	CHIP 2200PF 25V X7R
C819	065G0603222 22	CHIP 2200PF 25V X7R
C823	065G0603222 22	CHIP 2200PF 25V X7R
C839	065G0805102 31	1000PF 50V NPO
C840	065G0805102 31	1000PF 50V NPO
C805	065G0805104 32	CHIP 0.1U 50V X7R
C824	065G0805104 32	CHIP 0.1U 50V X7R
C907	065G0805104 32	CHIP 0.1U 50V X7R
C916	065G0805104 32	CHIP 0.1U 50V X7R
C930	065G0805104 32	CHIP 0.1U 50V X7R
C931	065G0805104 32	CHIP 0.1U 50V X7R
C822	065G0805105 22	CHIP 1UF 25V X7R 0805
C928	065G0805122 31	CHIP CAP 0805 1200PF J 50V NPO
C820	065G080522131G	220PF 50V NPO 2%
C911	065G0805224 22	CAIP CAP 0.22 UF 25V X7R
C909	065G0805224 32	0.22UF,K,50V,X7R
C845	065G0805225 12	CHIP 2.2UF 16V X7R 0805
C929	065G1206102 72	CHIP 1000PF 500V X7R
C912	065G1206102 72	CHIP 1000PF 500V X7R
D805	093G 64 38 D	DIODE BAW56 DIODES
D808	093G 64 38 D	DIODE BAW56 DIODES

D809	093G 64 44 S	LL4148WP
D916	093G 64 44 S	LL4148WP
D915	093G 64 44 S	LL4148WP
D903	093G 64 44 S	LL4148WP
D817	093G 64 44 S	LL4148WP
D814	093G 64 44 S	LL4148WP
D806	093G 64 44 S	LL4148WP
D801	093G 6433P	BAV99
D802	093G 6433P	BAV99
D803	093G 6433P	BAV99
D804	093G 6433P	BAV99
ZD921	093G 39S 15 T	RLZ15B LLDS
ZD922	093G 39S 25 T	RLZ5.1B LLDS
CN901	006G 31500	EYELET
IC904	056G 158 12	KIA431A-AT/P TO-92
C938	065G 2K152 1T6052	1.5NF/2KV Y5P +-10%
C906	065G 2K152 1T6052	1.5NF/2KV Y5P +-10%
C908	067G215Y2207KT	CAP 105°C 22UF M 50V KINGNICH
FB901	071G 55 29	FERRITE BEAD
F901	084G 55 1W	FUSE 4A 250V WICKMANN
D901	093G 6038P52T	PS102R
D900	093G1100 1052T	BA159GPT DC-41 CHENMKO
	715G2538 1	POWER BOARD PCB
	Q07G 7 T164	COMPOUND PALLET
	Q40G 19N68013A	RATING LABEL
	Q40G000268013A	TRY ME LABEL
	Q40G000268014A	TCO' 03 LABEL
	Q40G000268019A	SPLENDID LABEL
	Q41G780068027A	US WARRANTY CARD NON ZBD
	Q44G6002CP212A	PAPER CAP
	Q44G9063 1	EPS(L)
	Q44G9063 2	EPS(R)
	Q44G9063680 1A	19 LCD ASUS CARTON
	Q45G 76 28V13 R	PE BAG
	Q45G 88607 25	PE BAG FOR BASE
	Q45G 88609 87	EPE COVER FOR MONITOR
	Q52G 1185 69	ASUS BIG TAPE
	Q52G6019 24	TAPE-FIX FOR ASUS
	040G 58162435A	LABEL
	041G780061537A	TCO'03 CARD
	Q41G780068034A	QSG VB171D/VB191D
	Q45G 76 28 RN R	PE BAG MANUAL
	Q70G1700680 3A	CD MANUAL

12. Different Parts List

For VB191T

Diversity of T97HMKDDHGUSD compared with T97HMKDBHGUED		
Location	Part No.	Description
E089B	089G414A18N IS	POWER CORD
	Q40G 19N68015A	RATING LABEL
	Q40G000268021A	SPLENDIE ZBD LABEL
	Q41G780068024A	CHINA WARRANTY CARD
	Q44G9063680 2A	19 LCD ASUS CARTON
	Q45G 88614 45 R	OUT PE BAG

The BOM of T97HMKDBHGUSD is the same as T97HMKDBHGUED.

Diversity of T97HMKDTHGUSD compared with T97HMKDBHGUED		
Location	Location	Location
E089B	089G402A18N IS	POWER CORD/(TPV 共用)32E1818019
E078	078G 322 9 G	SPEAKER 8 OHM 1.5W L:230 MM 43X18MM
E750	750GLH90N3A11N	PANEL HSD190MEN3-A 19" HANNSTAR
	AUPC7QU5	AUDIO BOARD
C207	067G215Y4713RV	LOW E.S.R 470UF +-20% 16V
C205	067G215Y4713RV	LOW E.S.R 470UF +-20% 16V
C208	067T405V471 3P	EC 105°C CAP 470UF M 16V
CN201	088G 30214K	PHONE JACK 5PIN
R207	061G 60210252T	CFR 1K OHM +-5% 1/6W
R208	061G 60210252T	CFR 1K OHM +-5% 1/6W
R201	061G 60218352T	18KOHM 5% 1/6
R203	061G 60218352T	18KOHM 5% 1/6
R210	061G 60220352T	CFR 20K OHM+-5% 1/6W
R211	061G 60220352T	CFR 20K OHM+-5% 1/6W
R202	061G 60220452T	200KOHM 5% 1/6W
R212	061G 60222452T	220KOHM 5% 1/6W
C204	064G178J474 0T6951	CL21X. 0.47UF 50V +-5%
C206	064G178J474 0T6951	CL21X. 0.47UF 50V +-5%
C211	065G 444101 5T	100 PF 10% 50V Y5P
C212	065G 444101 5T	100 PF 10% 50V Y5P
C203	065G 450104 7T	0.1UF +80-20% 50V Y5V
C213	067G215Y1097NT	EC 1.0UF 50V KY50VB1M-TP5 5*11MM
C209	067G215Y1097NT	EC 1.0UF 50V KY50VB1M-TP5 5*11MM
C210	067G215Y1097NT	EC 1.0UF 50V KY50VB1M-TP5 5*11MM
	715G2709 1 3	AUDIO BOARD PCB

	Q90G6258 2	HEAT SINK
CN701	033G3802 9B Y	CONNECTOR 9P 2.0
U401	056G 562146	IC TSUM56AWHK-LF-1 PQFP-128
	PWPC942SU3	POWER G2538-3-X-X-7-071010
C903	063G107K474 US	0.47UF +-10%
C811	065G 6J1006ET	10PF 5% SL 6KV
C801	065G 6J1006ET	10PF 5% SL 6KV
CN901	087G 501 37 S	AC INLET ST-01DG-B2K-K
CN902	095G 825 9X504	WIRE HARNESS 9P(SCN)-9P(PLUG) 220MM
Q902	057G 417 4	PMBS3904/PHILIPS-SMT(04)
R929	061G0805102	RST CHIPR 1KOHM +-5% 1/8W
R921	061G1206102	RST CHIPR 1 KOHM +-5% 1/4W
R922	061G1206102	RST CHIPR 1 KOHM +-5% 1/4W
R923	061G1206102	RST CHIPR 1 KOHM +-5% 1/4W
R928	061G1206102	RST CHIPR 1 KOHM +-5% 1/4W
R856	061G1206330	RST CHIPR 33 OHM +-5% 1/4W
R858	061G1206330	RST CHIPR 33 OHM +-5% 1/4W
C841	065G0805102 31	1000PF 50V NPO
C838	065G0805102 31	1000PF 50V NPO
C910	065G0805102 32	CHIP 1000P 50VX7R 0805
D805	093G 64 38 P	BAW56
D903	093G 64 38 P	BAW56
D808	093G 64 38 P	BAW56
ZD902	093G 39S 61 T	DIODE RLZ16B ROHM
NR901	006G 31502	1.5MM RIVET
T901	006G 31502	1.5MM RIVET
D900	093G1100 1152T	DIODE PR1007R 1A/1000V DO-41
	715G2538 3	POWER BOARD PCB
	Q41G780068026B	TW WARRANTY CARD NON ZBD
	Q44G9091680 1B	19 LCD CARTON
	Q41G780068034B	QSG
	040G 582680 1A	CARTON LABEL

Diversity of T97HMKDDHGUSDZ compared with T97HMKDBHGUED		
Location	Location	Location
E08904	089G 17356X554	AUDIO CABLE
E08901	089G 728CAA DB	D-SUB
E08903	089G1748GAA AC	SIGNAL CABLE DVI GREATLAND
E08902	089G414A18N IS	POWER CORD 32E1818021(与 TPV 共用)
E09502	095G801412X 80	WIRE HARNESS
E078	078G 322 9 G	SPEAKER 8 OHM 1.5W L:230 MM 43X18MM
E750	750GLH90N3A11N	PANEL HSD190MEN3-A 19" HANNSTAR
	AUPC7QU5	AUDIO BOARD
C205	067G215Y4713RV	LOW E.S.R 470UF +-20% 16V
C207	067G215Y4713RV	LOW E.S.R 470UF +-20% 16V
C208	067T405V471 3P	EC 105°C CAP 470UF M 16V
CN201	088G 30214K	PHONE JACK 5PIN
R207	061G 60210252T	CFR 1K OHM +-5% 1/6W
R208	061G 60210252T	CFR 1K OHM +-5% 1/6W
R201	061G 60218352T	18KOHM 5% 1/6
R203	061G 60218352T	18KOHM 5% 1/6
R210	061G 60220352T	CFR 20K OHM+-5% 1/6W
R211	061G 60220352T	CFR 20K OHM+-5% 1/6W
R202	061G 60220452T	200KOHM 5% 1/6W
R212	061G 60222452T	220KOHM 5% 1/6W
C204	064G178J474 0T6951	CL21X. 0.47UF 50V +-5%
C206	064G178J474 0T6951	CL21X. 0.47UF 50V +-5%
C211	065G 444101 5T	100 PF 10% 50V Y5P
C212	065G 444101 5T	100 PF 10% 50V Y5P
C203	065G 450104 7T	0.1UF +80-20% 50V Y5V
C213	067G215Y1097NT	EC 1.0UF 50V KY50VB1M-TP5 5*11MM
C210	067G215Y1097NT	EC 1.0UF 50V KY50VB1M-TP5 5*11MM
C209	067G215Y1097NT	EC 1.0UF 50V KY50VB1M-TP5 5*11MM
	715G2709 1 3	AUDIO BOARD PCB
	Q90G6258 2	HEAT SINK
CN701	033G3802 9B Y	CONNECTOR 9P 2.0
U401	056G 562146	IC TSUM56AWHK-LF-1 PQFP-128
	PWPC942SU3	POWER BOARD
C903	063G107K474 US	0.47UF +-10%
C801	065G 6J1006ET	10PF 5% SL 6KV
C811	065G 6J1006ET	10PF 5% SL 6KV
CN901	087G 501 37 S	AC INLET ST-01DG-B2K-K
CN902	095G 825 9X504	WIRE HARNESS 9P(SCN)-9P(PLUG) 220MM

Q902	057G 417 4	PMBS3904/PHILIPS-SMT(04)
R929	061G0805102	RST CHIPR 1KOHM +-5% 1/8W
R921	061G1206102	RST CHIPR 1 KOHM +-5% 1/4W
R922	061G1206102	RST CHIPR 1 KOHM +-5% 1/4W
R923	061G1206102	RST CHIPR 1 KOHM +-5% 1/4W
R928	061G1206102	RST CHIPR 1 KOHM +-5% 1/4W
R856	061G1206330	RST CHIPR 33 OHM +-5% 1/4W
R858	061G1206330	RST CHIPR 33 OHM +-5% 1/4W
C841	065G0805102 31	1000PF 50V NPO
C838	065G0805102 31	1000PF 50V NPO
C910	065G0805102 32	CHIP 1000P 50VX7R 0805
D903	093G 64 38 P	BAW56
D805	093G 64 38 P	BAW56
D808	093G 64 38 P	BAW56
ZD902	093G 39S 61 T	DIODE RLZ16B ROHM
T901	006G 31502	1.5MM RIVET
NR901	006G 31502	1.5MM RIVET
D900	093G1100 1152T	DIODE PR1007R 1A/1000V DO-41
	715G2538 3	POWER BOARD PCB
	Q40G 19N68015A	RATING LABEL
	Q40G000268021A	SPLENDIE ZBD LABEL
	Q40G000268032A	CHINA LABEL
	Q41G780068024A	CHINA WARRANTY CARD
	Q44G9091680 2A	19 LCD CARTON
	Q45G 88614 45 R	OUT PE BAG
E09501	S95G801830154	LVDS ASS'Y
	041G 68623 1A	CERTIFICATED CARD
	Q41G780068034B	QSG

For VB191S

The BOM of T97HMKDBHGUSD is the same as T97HMKDBHGUED.

Diversity of T97HMWDKHGUSA compared with T97HMWDTHGUSAZ		
Location	Part No.	Description
E08903	089G 17356X554	AUDIO CABLE
E08902	089G 728HAA DB	D-SUB
E08901	089G402A18N CX	POWER CORD
E09502	095G801412X 80	WIRE HARNESS
E078	078G 322 9 G	SPEAKER 8 OHM 1.5W L:230 MM 43X18MM
E750	750GLH90N3A11N	PANEL HSD190MEN3-A 19" HANNSTAR
	AUPC7QU5	AUDIO BOARD
C205	067G215Y4713RV	LOW E.S.R 470UF +-20% 16V
C207	067G215Y4713RV	LOW E.S.R 470UF +-20% 16V
C208	067T405V471 3P	EC 105°C CAP 470UF M 16V
CN201	088G 30214K	PHONE JACK 5PIN
R207	061G 60210252T	CFR 1K OHM +-5% 1/6W
R208	061G 60210252T	CFR 1K OHM +-5% 1/6W
R201	061G 60218352T	18KOHM 5% 1/6
R203	061G 60218352T	18KOHM 5% 1/6
R210	061G 60220352T	CFR 20K OHM+-5% 1/6W
R211	061G 60220352T	CFR 20K OHM+-5% 1/6W
R202	061G 60220452T	200KOHM 5% 1/6W
R212	061G 60222452T	220KOHM 5% 1/6W
C204	064G178J474 0T6951	CL21X. 0.47UF 50V +-5%
C206	064G178J474 0T6951	CL21X. 0.47UF 50V +-5%
C211	065G 444101 5T	100 PF 10% 50V Y5P
C212	065G 444101 5T	100 PF 10% 50V Y5P
C203	065G 450104 7T	0.1UF +80-20% 50V Y5V
C210	067G215Y1097NT	EC 1.0UF 50V KY50VB1M-TP5 5*11MM
C209	067G215Y1097NT	EC 1.0UF 50V KY50VB1M-TP5 5*11MM
C213	067G215Y1097NT	EC 1.0UF 50V KY50VB1M-TP5 5*11MM
	715G2709 1 3	AUDIO BOARD PCB
	Q90G6258 2	HEAT SINK
CN701	033G3802 9B Y	CONNECTOR 9P 2.0
U401	056G 562152	IC TSUM16AWK-LF-1 PQFP-128
	PWPC942SU3	POWER BOARD
C903	063G107K474 US	0.47UF +-10%
C811	065G 6J1006ET	10PF 5% SL 6KV
C801	065G 6J1006ET	10PF 5% SL 6KV
CN901	087G 501 37 S	AC INLET ST-01DG-B2K-K

CN902	095G 825 9X504	WIRE HARNESS 9P(SCN)-9P(PLUG) 220MM
Q902	057G 417 4	PMBS3904/PHILIPS-SMT(04)
R929	061G0805102	RST CHIPR 1KOHM +-5% 1/8W
R921	061G1206102	RST CHIPR 1 KOHM +-5% 1/4W
R922	061G1206102	RST CHIPR 1 KOHM +-5% 1/4W
R923	061G1206102	RST CHIPR 1 KOHM +-5% 1/4W
R928	061G1206102	RST CHIPR 1 KOHM +-5% 1/4W
R856	061G1206330	RST CHIPR 33 OHM +-5% 1/4W
R858	061G1206330	RST CHIPR 33 OHM +-5% 1/4W
C841	065G0805102 31	1000PF 50V NPO
C838	065G0805102 31	1000PF 50V NPO
C910	065G0805102 32	CHIP 1000P 50VX7R 0805
D903	093G 64 38 P	BAW56
D805	093G 64 38 P	BAW56
D808	093G 64 38 P	BAW56
ZD902	093G 39S 61 T	DIODE RLZ16B ROHM
T901	006G 31502	1.5MM RIVET
NR901	006G 31502	1.5MM RIVET
D900	093G1100 1152T	DIODE PR1007R 1A/1000V DO-41
	715G2538 3	POWER BOARD PCB
	Q40G000268025A	SPLENDID LABEL-VB191S ZBD
	Q41G780068029A	TW WARRANTY CARD ZBD
	Q44G9091680 1B	19 LCD CARTON
E09501	S95G801830154	LVDS ASS'Y
	Q41G780068034B	QSG
	040G 582680 1A	CARTON LABEL